

# UNIQUE<sup>®</sup>

APPLIANCES

## PRESTIGE

by UNIQUE

# PRESTIGE GAS RANGE

## 20" (50.8 cm) CONVECTION GAS RANGE (NG & LPG CONVERTIBLE)

---

**MODEL NUMBERS:** UGP-20V PC1 S/S, UGP-20V PC1 W, UGP-20V PC1 B



**Intertek**  
4009900

---

### OWNER'S GUIDE

serial number:

NOV20V3

# PRESTIGE GAS RANGE 20" (50.8 CM) CONVECTION GAS RANGE (NG & LPG CONVERTIBLE)

## Installation & Owner's Manual

### This manual contains information for:

- Important Safeguards
- Installation
- Use and Care

Certain ranges come equipped with special features. Determine from a study of your range which of the instructions given in this booklet pertain to your range.

This booklet gives valuable instructions covering the installation, adjustment and use of your range.

### How to Obtain Service and/or Parts

When your range does not operate in accordance with the instructions in the manual, you should contact the dealer in your immediate vicinity for service. Or, the purchaser may contact the service organization noted on the warranty.

### Important

TO THE OWNER OF THE RANGE: Retain this owner's manual for future reference.

TO THE INSTALLER: Leave this owner's manual with the range.

## Read and save these instructions



### READ AND SAVE THESE INSTRUCTIONS

*Have the dealer where you purchase your new range install it or have him recommend a qualified installer. Installation must conform with local codes. In the absence of local codes, the installation must conform with the National Fuel Gas Code, ANSI Z223.1-Latest Edition in the U.S.A. or the CAN/CGA B149.1 or .2 Installation Codes in Canada.*

# UNIQUE<sup>®</sup>

APPLIANCES

## MANUFACTURED & CERTIFIED BY Unique Appliances

**WARNING:** If the information in this manual is not followed exactly, a fire or explosion may result causing property damage, personal injury or death.

- Do not store or use gasoline or other flammable vapors and liquids in the vicinity of this or any other appliance.
- WHAT TO DO IF YOU SMELL GAS
  - Do not try to light any appliance.
  - Do not touch any electrical switch.
  - Do not use any phone in your building.
  - Immediately call your gas supplier from a neighbor's phone. Follow the gas supplier's instructions.
  - If you cannot reach your gas supplier, call the fire department.
- Installation and service must be performed by a qualified installer, service agency or the gas supplier.

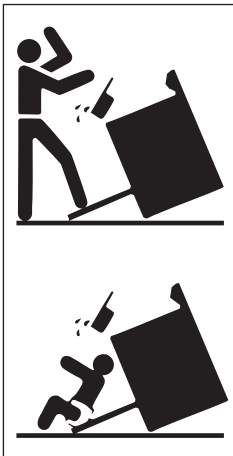

**WARNING**

To reduce the risk of tipping the appliance by abnormal usage or improper door loading, the appliance must be secured by properly installing the Anti-Tip device packed with the appliance. To check if the device is installed and engaged properly. Carefully tip the range forward. The Anti-Tip device should engage and prevent the range from tipping over.

**If this range is removed for any reason, service or cleaning, etc., it must be replaced as outlined in the installation instructions before placing the range back in operation.**

X2



Range Foot Anti-tip Bracket

**Making sure the anti-tip bracket is installed:**

- Slide range forward.
- Look for the anti-tip bracket securely attached to floor.
- Slide range back so rear range foot is under anti-tip bracket.

# TABLE OF CONTENTS

IMPORTANT SAFEGUARDS . . . . .	7
CARBON MONOXIDE WARNING . . . . .	13
ENERGY SAVING IDEAS . . . . .	14
INSTALLATION INSTRUCTIONS . . . . .	15
HOW TO INSTALL THE BACKSPLASH . . . . .	16
GAS CONNECTION . . . . .	17
WALL CLEARANCES & ANTI-TIP LOCATION . . . . .	20
NG CONVERSION INSTRUCTIONS . . . . .	22
CHECKING FOR MANIFOLD GAS PRESSURE . . . . .	26
ADJUSTING THE TOP BURNER AND OVEN FLAME . . . . .	27
OPERATION OF RANGE . . . . .	30
BROILING . . . . .	35
CLEANING THE RANGE . . . . .	36
CARE AND MAINTENANCE . . . . .	40
TROUBLESHOOTING GUIDE . . . . .	42
WIRING DIAGRAM . . . . .	44
PARTS DIAGRAM AND LIST . . . . .	45
WARRANTY . . . . .	50
PRODUCT REGISTRATION . . . . .	51
CONTACT US . . . . .	51



## BEFORE USING YOUR GAS RANGE



### HAVE THIS RANGE INSTALLED BY A QUALIFIED INSTALLER.

Improper installation, adjustment, alteration, services, or maintenance can cause injury or property damage. Consult a qualified installer, service agency, or the gas supplier.

### BEFORE USING YOUR GAS RANGE:

- Remove the exterior and interior packing.
  - Remove the protective film on steel and aluminum parts.
  - Check to be sure you have all of the parts listed below.
    - 1 backsplash
    - LP gas conversion packet (injectors for LP gas, 6pcs)
    - 2 anti-tip brackets
    - 2 pan supports
    - 2 oven racks
    - 4 caps and bases in the burner assembly
    - 1 broiler grid
    - 1 broiler tray
    - 1 regulator (pre-installed)
    - 5 screws for backsplash
    - 1 instruction/installation manual
- 
- Clean the interior surface with lukewarm water using a soft cloth
  - Have the installer show you the location of the range's gas shut-off valve and how to shut it off if necessary.
  - Have your range installed and properly grounded by a qualified installer in accordance with the installation instructions.
  - Do not attempt to repair or replace any part of your range unless it is specifically recommended in this manual.
  - Be sure your range is correctly adjusted by a qualified service technician or installer for the type of gas (natural or LP) that is being used.
  - Do not remove permanently affixed labels, warnings, or plates from the unit. This may void the warranty.
  - The installer should leave these instructions with the consumer who should retain for local inspector's use and for future reference.
  - Please observe all local and national codes and ordinances.

## WELCOME & CONGRATULATIONS

Congratulations on your purchase of a UNIQUE range! We are very proud of our product – and are completely committed to providing you with the best service possible. Your satisfaction is our #1 priority. Please read this manual very carefully. It contains valuable information on how to properly maintain your new Unique propane range.

We know you will enjoy your new range and Thank You for choosing one of our Unique Appliances!. We hope you will consider us for future purchases.

### PLEASE READ AND SAVE THESE INSTRUCTIONS

This manual provides specific operation instructions for your model. Use your range only as instructed in this manual. These instructions are not meant to cover every possible condition and situation that may occur. Common sense and caution must be practiced when installing, operating and maintaining the appliance.

Record in the space provided below the Model No. and Serial No. of this appliance.

These numbers are found on the serial plate located at the bottom drawer.

Model No. \_\_\_\_\_

Serial No. \_\_\_\_\_

Purchase Date \_\_\_\_\_

Record these numbers for future use.

**IMPORTANT:** Keep a copy of your bill of sale. The date on the bill establishes the warranty period should service be required. If service is performed, it is in your best interest to obtain and keep all receipts.

### PLEASE DO THIS NOW!

Please visit our website at <https://UniqueAppliances.com/product-registration/> to register your product.

# READ ALL IMPORTANT SAFEGUARDS AND ALL INSTRUCTIONS BEFORE USING THE APPLIANCE.

## IF YOU SMELL GAS:

- Open windows
- Don't touch electrical switches
- Extinguish any open flame
- Immediately call your gas supplier

## FOR YOUR SAFETY:

- Keep appliance area clear and free from combustible materials gasoline and other flammable vapors and liquids.

## WARNINGS

Destroy the carton and plastic bags after the range is unpacked. Children should not use packaging material for play. Cartons covered with rugs, bedspreads, or plastic sheets can become airtight chambers. Remove all staples from the carton. Staples can cause severe cuts and destroy finishes if they come in contact with other appliances or furniture.

**Be safety conscious.** The preparation of food in an oven requires temperatures that could cause severe burns. Before using this new appliance, carefully read and follow all instructions.



The California Safe Drinking Water and Toxic Enforcement Act of 1986 (Proposition 65) requires the Governor of California to publish a list of substances known to the State of California to cause cancer or reproductive harm. In addition, businesses must warn customers of potential exposure to such substances.

Users of this appliance are hereby warned that the burning of gas can result in low-level exposure to some of the listed substances, including formaldehyde, benzene, soot and carbon monoxide. This is caused primarily from the incomplete combustion of natural gas or LP fuel.

Properly adjusted burners will minimize incomplete combustion. Exposure to these substances can also be minimized by properly venting the burners by opening a window or using a ventilating hood or fan.

**Notice: Never keep pet birds in the kitchen. Birds have a very sensitive respiratory system. Fumes released from cooking oil, fat, margarine or overheated non-stick cookware may be harmful or fatal to birds.**

**PROPER INSTALLATION:** Be sure a qualified technician in accordance with the National Fuel Gas Code ANSI Z223.1/NFPA54 properly installs your appliance. Install only per installation instructions provided in the literature package for this range. Be sure leveling legs are in place at the bottom corners of the range. If necessary, raise or lower the leveling legs at the base of the range by turning clockwise or counter clockwise to insure a level range.

Ask your dealer to recommend a qualified technician and an authorized repair service. Have the technician familiarize you with the locations of the manual gas shut off valve and gas meter in the event it is necessary to shut off gas supply to the unit during an emergency.

**The following situations may cause serious bodily harm, death or property damage.**

**TO REDUCE THE RISK OF TIPPING OF THE RANGE, THE RANGE MUST BE SECURED BY A PROPERLY INSTALLED ANTI-TIP BRACKET PROVIDED WITH THE RANGE. TO CHECK IF THE DEVICE IS INSTALLED AND ENGAGED PROPERLY, CAREFULLY TIP THE RANGE FORWARD. THE ANTI-TIP DEVICE SHOULD ENGAGE AND PREVENT THE RANGE FROM TIPPING OVER. REFER TO THE INSTALLATION INSTRUCTIONS PACKAGED WITH THE ANTI-TIP BRACKET FOR PROPER ANTI-TIP BRACKET INSTALLATION.**

- **Never leave children alone or unattended in the area where an appliance is in use.** They should never be allowed to sit or stand on any part of the appliance. Never leave the oven door open when the range is unattended.
- **Do not store items of interest to children in the cabinets above a range or on the backguard of a range.** Children climbing on the range to reach the items could be seriously injured.

**Do not allow children to climb or play around the range.** The weight of a child on an open oven door may cause the range to tip, resulting in serious burns or other injury.

**IMPORTANT:** Observe all governing codes and ordinances. Do not obstruct flow of combustion and ventilation air.

**USER SERVICING:** Do not repair or replace any part of the appliance unless specifically recommended in this owner's guide. Only a qualified technician should do all other servicing. This will reduce the risk of personal injury and damage to the range.

**Storage in or on appliance:** Flammable materials should not be stored in an oven, near surface burners or in the broiler section. This includes paper, plastic and cloth items, such as cookbooks, plastic ware and towels, as well as flammable liquids. Do not use the oven for storage. Do not store explosives, such as aerosol cans, on or near the range.

**Remove the oven door from any unused range if it is to be stored or discarded.**

**Stepping, leaning or sitting on the doors or broiler section of this range can result in serious injuries and cause damage to the range.**



**The following situations could cause bodily injury or property damage.**

**DO NOT TOUCH SURFACE BURNERS, AREAS NEAR THESE BURNERS, OVEN BURNERS OR INTERIOR SURFACES OF THE OVEN.** Both surface burners and oven burners may be hot even though the flame is not visible. Areas near surface burners may become hot enough to cause burns. During and after use, do not touch, or let clothing or other flammable materials touch these areas until they have had sufficient time to cool. Among these areas are the range, surfaces facing the range, the oven vent openings and surfaces near these openings, oven door and windows.



**NEVER use this appliance as a space heater to heat or warm the room.** Doing so may result in carbon monoxide poisoning and overheating of the oven.

**Wear proper apparel.** Loose fitting or hanging garments should never be worn while using the appliance. Do not let clothing or other flammable materials contact surface burners or interior surfaces of the oven until they have had sufficient time to cool.

**Never modify or alter the construction of the range.** Do not remove leveling legs, panels, wire covers, anti-tip brackets or any other permanent part of the product.

**When heating fat or grease, watch it closely.** Fat or grease may catch fire if allowed to become too hot.

**Do not use water or flour on grease fires.** Smother the fire with a pan lid, baking soda or use a dry chemical or foam-type extinguisher.

**Operation of the Surface Burners.** When the burners are operated for the first time, a small amount of smoke may be generated due to tape residue or manufacturing lubrication, **this is not dangerous.** Operate the burners for about five minutes to rid the burners of this material before cooking.

**Use only dry potholders.** Wet or damp potholders on hot surfaces could result in burns from steam. Do not let the potholder touch hot heating areas. Do not use a towel or other bulky cloth instead of a potholder.

**Use proper flame size.** Adjust flame size so it does not extend beyond the edge of the cookware. The use of undersized cookware will expose a portion of the burner flame and may result in severe burns or direct contact and ignition of clothing. Also, proper relationship of cookware to burner will improve efficiency.



**NEVER cover any slots, holes or passages in the oven bottom or cover an entire rack with materials such as aluminum foil.** Doing so blocks air flow through the oven and may cause carbon monoxide poisoning. Aluminum foil linings may also trap heat, causing a fire hazard. Refer to the cleaning section of this manual for more information on the use of aluminum foil.

**Placement of oven racks:** Always place an oven rack in the desired location while the oven is cool. If a rack must be moved when the oven is hot, use potholders and grasp the rack with both hands to reposition. Do not let potholders contact hot oven walls. Remove all cookware from the rack before moving.

**Do not heat unopened food containers.** Build-up of pressure may cause the container to burst and result in injury.

**Keep the oven vent duct unobstructed.** The oven vent is located along the bottom of the back guard. Touching the surfaces in the vent area when the oven is being operated may cause severe burns. Also, do not place plastic or heat-sensitive items on or near the oven vents. These items could melt or ignite. The range requires fresh air for proper burner combustion. Do not block the flow of air around the base or beneath the lower front panel of the range.

**Use care when opening oven door: Stand to the side of the oven when opening the oven door.** Slowly open the door to allow hot air or steam to escape before removing or replacing food.

**Know which knob controls each burner.** Place a pan of food on the burner before turning it on, and turn the burner off before removing the pan. Always turn to the full position when igniting top burners. Then adjust the flame size so it does not extend beyond the edge of the cookware.

**Cookware handles should be turned inward and not extend over adjacent surface burners.** To reduce the risk of burns, ignition of flammable materials, and spillage due to unintentional contact with the cookware, the handle of a cookware should be positioned so that it is turned inward, and does not extend over adjacent surface burners.

**Never leave the surface burners unattended.** Boilovers may cause smoking, greasy spill-overs may catch fire or a pan which has boiled dry may melt.

**Do not place hands between the spring tension hinge and the oven door frame when you are removing the oven door.** You could pinch your fingers.

**Allow parts to cool to room temperature before touching or removing them from the range.** When a surface burner is first turned off, the burner and grate are hot enough to cause burns.

**Clean the range regularly to keep all parts free of fat or grease, which could catch fire.** Pay particular attention to the area underneath each surface burner. Exhaust fan ventilating hoods and grease filters should be clean. Do not allow fat or grease to accumulate. Greasy deposits in the fan could catch fire. Refer to the hood manufacturer's instructions for cleaning.

**Do not use a "cyclonic" range hood with this product.** Some range hoods circulate air by blowing downward toward the range top then drawing the air back up into the hood. This creates a "cyclonic" air wash that is designed for electric ranges only. A "cyclonic" hood may cause the burners of a gas range to operate improperly.

**Glazed cookware:** Only certain types of glass, glass/ceramic, ceramic, earthenware, or other glazed cookware are suitable for rangetop service without breaking, due to the sudden change in temperature. Check the manufacturer's recommendations for rangetop use.

**Do not place plastic salt and pepper shakers, spoon holders or plastic wrappings on top of the range.** These items could melt or ignite. Potholders, towels or wooden spoons could catch fire if placed too close to the flame.

**Do not use a wok equipped with a metal ring that extends beyond the burner.** Because this ring traps heat, the burner and grate could be damaged. Also, the burner may not work properly, creating a carbon monoxide level above current health standards.

**Do not clean the oven door gasket.** The door gasket is essential for a good seal. Care should be taken not to rub, damage or move the gasket.

**Flexible Connectors:** If the gas range/oven is connected to a gas supply with a metal flexible connector, move the range/oven with CAUTION for service or cleaning.

**Flexible connectors are not intended for repeated bending. Do not allow cleaners to make contact with flexible connectors.**

**The connector and its fittings are designed for use only on the original installation and are not to be reused for another appliance or at another location. Connectors must comply with ANSI Z21.24.**

**It's good practice for each household to have an appropriate fire extinguisher for use in the event of a house fire.**

**NOTE:** The instructions appearing in this owner's guide are not meant to cover every possible condition and situation that may occur. Common sense and caution must be practiced when operating and maintaining any appliance.



On sealed burner models never attempt to operate the surface burners without the cooktop, burner caps and ignition wires firmly in place. There is a risk of fire and/or explosion which could result in personal injury or property loss.



## **ELECTRICAL GROUNDING INSTRUCTIONS**

**FOR PERSONAL SAFETY, THIS APPLIANCE MUST BE PROPERLY GROUNDED.**

This appliance is equipped with a three-prong grounding plug for your protection against shock hazard and should be plugged directly into a properly grounded socket. Do not cut or remove the grounding prong from the plug.

- The gas range must be installed with all electrical connections in accordance with state and local codes. A standard electrical supply (115 V AC only, 60 Hz), properly grounded in accordance with the National Electrical Code and local codes and ordinances is required.

Do not under any circumstances cut or remove the third (ground) prong from the power plug. Electrical installation should comply with national and local codes.

## **REPLACEMENT PARTS**

Only authorized replacement parts may be used in performing service on the range. Replacement parts are available from factory authorized parts distributors. Contact the nearest Unique parts distributor in your area.





## **CARBON MONOXIDE WARNING**

**Carbon Monoxide is a possible danger when using any gas powered appliance.**

**All gas appliances MUST be installed by a licensed professional who is familiar with the Carbon Monoxide levels appropriate for each appliance.**

**The American Gas Association publishes CO emissions for appliances and heating equipment through the ANSI Std. Z21.1**

**The EPA reports that a maximum CO (Carbon Monoxide) level of 9 PPM over a 24 hour period is the residential interior ambient level standard.**

**(A properly ventilated home will have a normal CO level of less than 5 PPM.)**

### **NON-VENTED GAS COOKING APPLIANCES:**

**Non-vented gas cooking appliances in a residential application are normally used for a short period of time. The CO generated during the operation will disperse to the air in the home and be purged to the outside through the normal air exchange.**

# ENERGY-SAVING IDEAS

## **SURFACE COOKING**

Use lids when surface cooking. A lid traps steam and uses it to speed up the cooking process. If you have a pressure cooker or vegetable steamer, use it. You'll waste fewer vitamins, save time and cut energy costs.

Use medium-weight, flat bottomed pans that match the flame size. Choose pans made of metals that conduct heat well.

When cooking on a surface burner, use as little water as possible to reduce cooking time.

## **OVEN COOKING**

Preheat the oven only when a recipe tells you. Put roasts and casseroles into a cold oven; then turn on the oven.

Opening the oven door often to check on foods wastes energy.

Use the oven to prepare complete meals. For instance, start a roast, add vegetables when the meat is half-cooked, and then warm rolls or dessert after the main dishes are cooked.

Thaw frozen foods before cooking. Thawed food requires less cooking energy than frozen food.

Make it a habit to turn the oven off before removing the cooked food.

# INSTALLATION INSTRUCTIONS

***Be sure appliance is properly installed and grounded by a qualified technician.***

It is the responsibility of the technician to make certain that your range is properly installed. Situations caused by improper installation are not covered under the warranty. Any expenses incurred due to such situations will not be paid by the manufacturer of the appliance.



**⚠ WARNING** A child or adult can tip the range and be killed. Install the anti-tip device to the structure and/or the range. Verify the anti-tip device has been properly installed and engaged. Engage the range to the anti-tip device by ensuring the anti-tip device is re-engaged when the range is moved. Re-engage the anti-tip device if the range is moved. Do not operate the range without the anti-tip device in place and engaged. See installation instructions for details. Failure to do so can result in death or serious burns to children or adults.

If this range is removed for any reason, (eg. service or cleaning), it must be replaced as outlined before placing the range back in operation.

## LEVELLING A FREE-STANDING RANGE

All free-standing ranges must be level to obtain proper cooking results. The leveling legs should be screwed into the corner brackets. Place pan or measuring cup partially filled with water or a level on the oven rack. Adjust the leveling legs until the range is level. The top of the side panels should be level with the counter top.

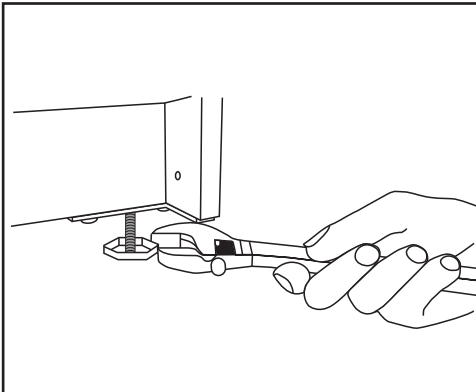

**X2**



Range Foot Anti-tip Bracket

### **Making sure the anti-tip bracket is installed:**

- Slide range forward.
- Look for the anti-tip bracket securely attached to floor.
- Slide range back so rear range foot is under anti-tip bracket.

## HOW TO INSTALL THE BACKSPLASH

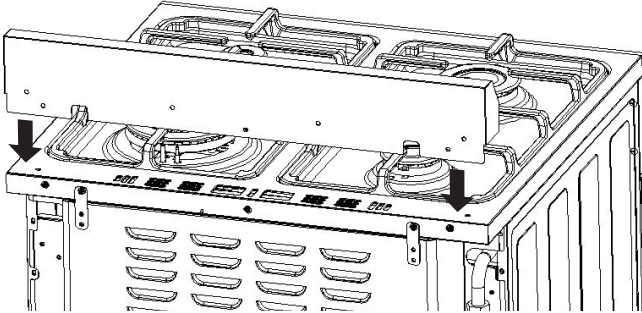

1. Align the backsplash to the rear part of the cooktop as shown in the diagram.

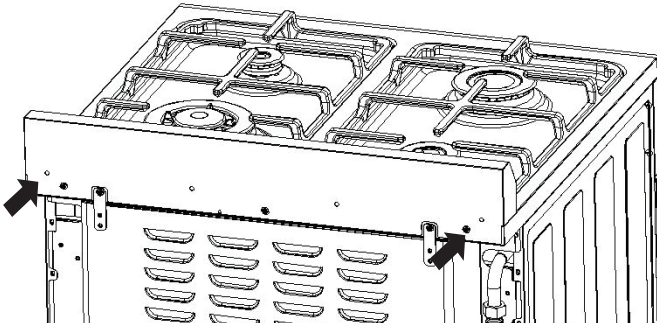

2. Secure the backsplash to the cooktop from the back using the 2 Phillips head screws provided as shown in the diagram.

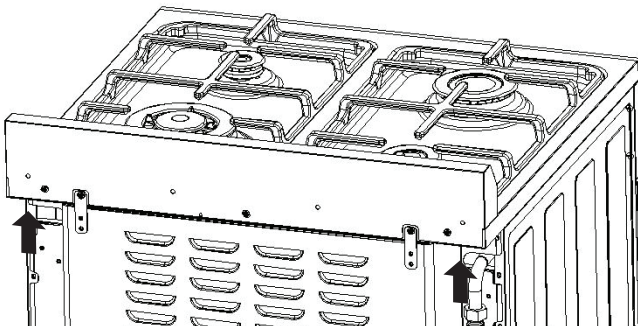

3. Secure the backsplash from the bottom using the Phillips head screws provided as shown in the diagram.

# GAS CONNECTIONS

**NOTICE TO MASSACHUSETTS APPLIANCE DEALERS:**

Be sure this document is included in all gas range appliances sold to consumers in the State of Massachusetts.

**NOTICE: Massachusetts law requires the following:**

- Appliances must be installed by a licensed plumber or gas fitter.
- Appliances must be connected with a three (3) foot (36" maximum length) flexible gas connector and
- A "T" handle type manual gas valve in the gas supply line to the appliance.

Have the dealer where you purchase your new range install it or have him recommend a qualified installer. Installation must conform with local codes. In the absence of local codes, the installation must conform with the National Fuel Gas Code, ANSI Z223.1-Latest Edition in the U.S.A. or the CAN/CGA B149.1 or .2 Installation Codes in Canada.

The range should be connected to the supply line with ½" black iron pipe or a certified flexible type range connector. To prevent gas leaks, put an approved sealing compound, which is resistant to liquefied petroleum gases, on all threaded connections.

Important: Do not apply pressure directly to the range manifold pipe when tightening supply connections. The manifold pipe should be held securely at the pressure regulator to prevent twisting. Hold the pressure regulator with a wrench during the tightening of the connection, or the manifold pipe may be twisted and split, and cause a dangerous leak.

The installation of ranges designed for manufactured (mobile) home installation must conform with the Manufactured Construction and Safety, Title 24 CFR, Part 3280, [formerly the Federal standard for Mobile Home Construction and Safety, Title 24, HUD (Part 280)] in the U.S.A. or C.S.A. Standard CAN/CGA Z240.4.2 in Canada or, when such standards are not applicable with local codes.

The installation of ranges designed for recreational vehicle installation must conform to state or other codes and in the absence of such codes with the standard for recreational vehicles ANSI A119.2.2-1982 in the U.S.A. or CAN/CGA Z240.4.2 in Canada. The installation of appliances designed for recreational park trailers must conform to recreational park trailers, ANSI A119.5.

Note: Check all piping connections in the unit for leaks. Never use an open flame to check for gas leaks. Use a soap solution with a recommended ratio of 75% water and 25% dish washing soap. It's possible for connections made at the factory to leak, due to vibration encountered in transportation. Make certain you have checked them all, and repair any connections that leak.

## GAS CONNECTIONS (continued)

The appliance and its individual shut-off valve must be disconnected from the gas supply piping system during any pressure testing of that system at test pressures in excess of ½ psig.

The appliance must be isolated from the gas supply piping system by closing its individual manual shut-off valve during any pressure testing of the gas supply piping system at test pressures equal to or less than ½ psig.

- Gas line shut-off valve

### TOOLS YOU WILL NEED

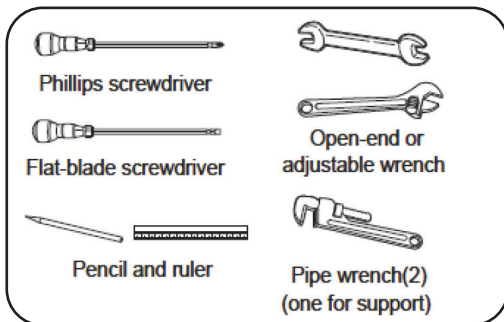

### MATERIALS YOU MAY NEED

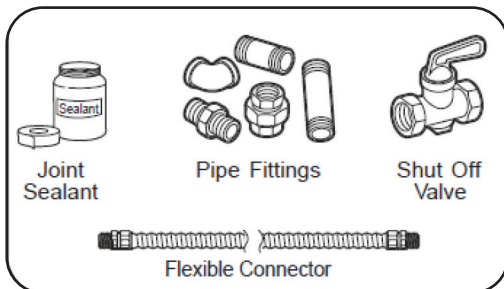

- To reduce the possibility of gas leaks, apply Teflon tape or a thread compound approved for use with LP or Natural gases to all threaded connections.
- Use a flexible appliance connector to connect your gas supply to the appliance. A 3 foot length is recommended for ease of installation but other lengths are acceptable. Never use an old connector when installing a new range.
- Check for leaks using a leak detector or soapy water with a recommended ratio of 75% water, 25% dish washing soap.

### Installation

It is the responsibility of the installer to make certain that the range is properly adjusted at the time of installation. Situations caused by improper adjustments or improper installation are not covered under the warranty. Any expenses incurred due to such situations will not be paid by the manufacturer of the appliance.

### Connecting gas to range

This range is designed to operate at a pressure of 5" of water column on natural gas (NG) or 10" of water column on propane gas (LPG).

Make sure you are supplying your range with the type of gas for which it is designed. **This range comes equipped from the factory equipped for use with NG (natural gas).** This range is convertible for use on propane (LPG) also (propane orifices included in the packaging).

## GAS CONNECTIONS (continued)

When using this on LPG gas, conversion must be made by a qualified LPG installer before attempting to operate the range on that gas.

For correct operation, the pressure of natural gas supplied to the regulator should be between 4" and 5" of water column. For LP gas, the pressure supplied must be between 10" and 12" of water column.

When checking for correct operation of the regulator, the inlet pressure must be at least 1" more than the operating -manifold- pressure as given above. The pressure regulator located at the back of the range manifold must remain in the supply line regardless of whether natural or LP gas is being used.

Regulator is only good for psi (14" w.c.) so test pressure must not exceed  $\frac{1}{2}$ " psi.

Shut off the main gas supply valve before removing the old range and leave it off until the new hook-up has been completed.

Because hard piping restricts movement of the range, the use of a CSA/ETL certified flexible metal appliance connector is recommended unless local codes require a hardpiped connection. Never reuse an old connector when installing a new range. If the hard piping method is used, you must carefully align the pipe; the range cannot be moved after the connection is made.

To prevent gas leaks, use pipe joint compound resistant to LP or NG gases (depending on set up) on all male -external- pipe threads.

1. In an easily accessible location, install a service manual gas shut off valve. Be sure everyone operating the range knows where and how to shut off the gas supply to the range.
2. When all connections have been made, be sure all range controls are in the off position and turn on the main gas supply valve. Check for gas leaks by using a soap and water solution. If a gas leak is present, shut off gas immediately, tighten all connections, and retest for leaks.
3. Any opening in the wall behind the appliance and in the floor under the appliance must be sealed.

### **After installation:**

1. Check ignition of cooktop burners.
2. Check ignition of oven burner.
3. Check ignition of broiler burner.
4. Check for gas leaks at all gas connections (using a gas detector, never a flame)





# WALL CLEARANCES & ANTI-TIP LOCATION (continued)

## Anti-Tip Bracket Location

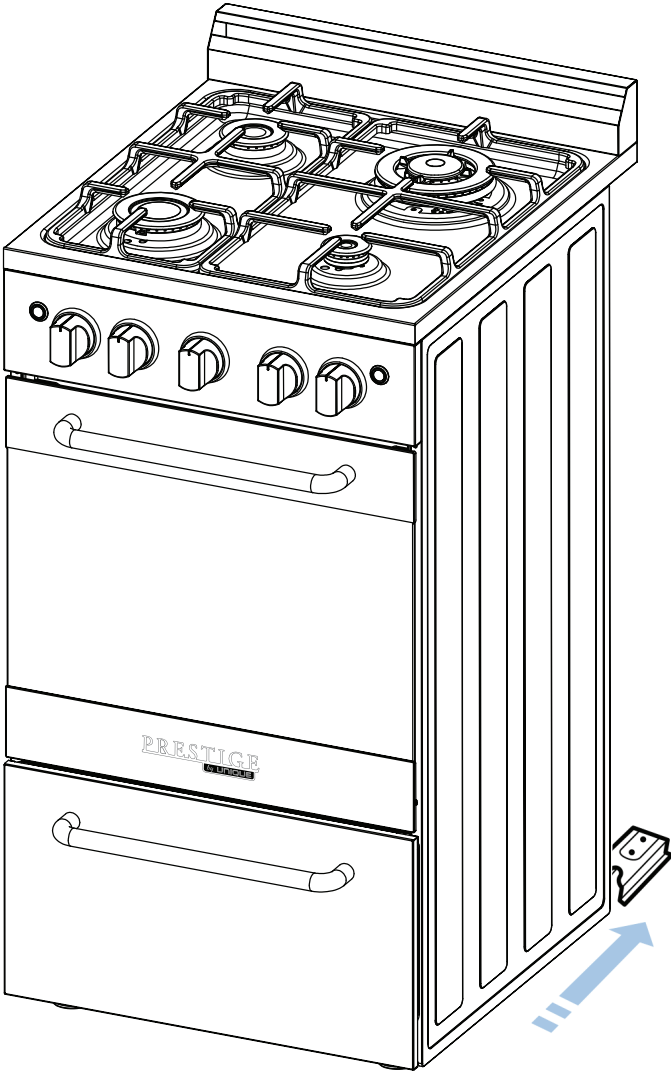
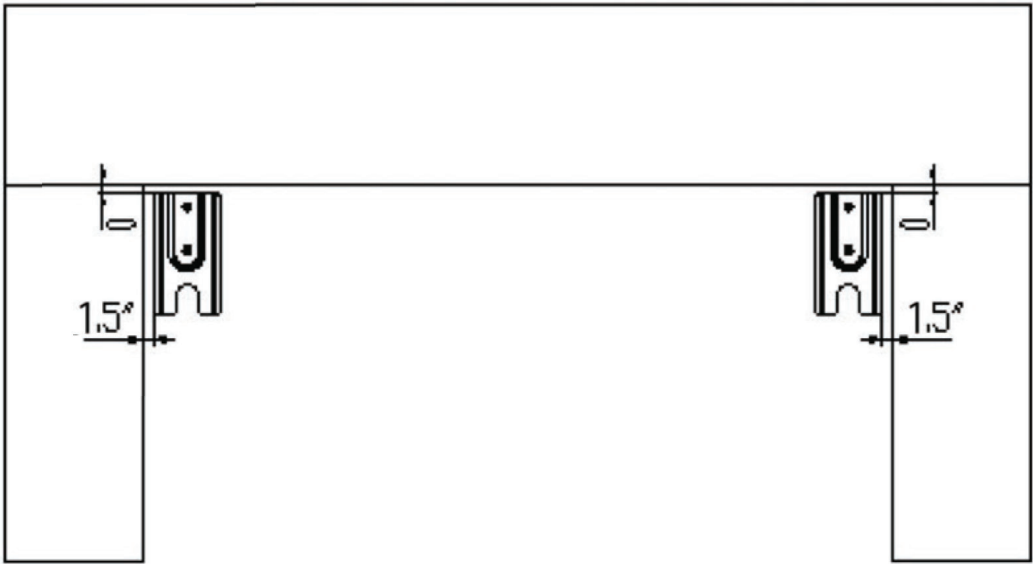

# GAS RANGE CONVERSION

## TO CONVERT APPLICATION AND/OR ADJUST FROM NG TO LPG

The range is set for use with Natural Gas (NG). The factory setting is indicated on the serial plate. When set for Natural Gas operation, the pressure regulator will regulate the gas to 4" water column pressure. When set for Liquid Propane Gas (LPG) operation, the pressure regulator will regulate the pressure to 10" water column.

## NATURAL GAS TO LIQUID PROPANE GAS CONVERSION

The conversion kit must be installed by qualified service agency.

**WARNING:** Please ensure before beginning converting the appliance that the gas supply is shut off and the electrical connection is disconnected. Failure to do can result in injury or property damage.

“This conversion kit shall be installed by a qualified service agency in accordance with the manufacturer’s instructions and all applicable codes and requirements of the authority having jurisdiction. If the information in these instructions is not followed exactly, a fire, explosion or production of carbon monoxide may result in property damage, personal injury or loss of life. The qualified service agency is responsible for the proper installation of this kit. The installation is not proper and complete until the operation of the converted appliances is checked as specified in the manufacturer’s instructions supplied with the kit.”

### 20" MODEL

Natural Gas Orifices						
BTU	2,700	5,000	11,000	8,500	7,000	8,200
BURNER	Auxiliary Burner	Semi-Rapid Burner	Triple Burner	Rapid Burner	Broil Burner	Oven Burner
POSITION	Front Right	Back Left	Back Right	Front Left		
ORIFICE	0.73	1.0	1.5	1.3	1.24	1.3

Liquid Propane Gas Orifices						
BTU	2,700	5,000	11,000	8,500	7,000	8,200
BURNER	Auxiliary Burner	Semi-Rapid Burner	Triple Burner	Rapid Burner	Broil Burner	Oven Burner
POSITION	Front Right	Back Left	Back Right	Front Left		
ORIFICE	0.53	0.68	1.0	0.9	0.8	0.82

## GAS RANGE CONVERSION (continued)

**ATTENTION: YOUR PRODUCT IS PRE-INSTALLED WITH NATURAL GAS INJECTORS AND REGULATOR.**

**IF YOU ARE USING LP GAS, PLEASE REFER TO THE INSTALLATION INSTRUCTIONS INCLUDED WITH THE CONVERSION KIT.**

### CONVERTIBLE PRESSURE REGULATOR

The range is shipped to operate on NG. LPG orifices for adjusting the minimum flame are shipped with the unit in a separate envelope with the manual. The inlet pressure of the gas supply shall be in accordance with the nominal inlet pressure of the regulator used on the range or 1/2 psig maximum. The range should be tested by pressurizing the regulator with an inlet pressure at least 1" water column above the manufacturer's specified manifold pressure shown on the serial plate.

#### ORIFICES

UGP 20V PC1 S/S			<b>NOZZLE (LPG)</b>
UGP 20V PC1 W			
UGP 20V PC1 B			
<b>RL</b> ○ 0.68	<b>BROILER</b> ○ 0.8	<b>RR</b> ○ 1.0	
<b>FL</b> ○ 0.9	<b>OVEN</b> ○ 0.82	<b>FR</b> ○ 0.53	

#### SCREWDRIVER

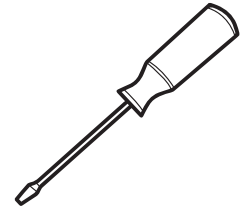

### CONVERTIBLE PRESSURE REGULATOR

The range is shipped to operate on NG. LPG orifices and a special screwdriver for adjusting the minimum flame are shipped with the unit in a separate envelope with the manual. The inlet pressure of the gas supply shall be in accordance with the nominal inlet pressure of the regulator used on the range or 1/2 psig maximum. The range should be tested by pressurizing the regulator with an inlet pressure at least 1 inch water column above the manufacturer's specified manifold pressure shown on the serial plate.

1. **CAUTION:** Before proceeding with the conversion, shut off the gas supply to the appliance prior to disconnecting the electrical power
2. Locate convertible regulator at the back of the range, left side facing appliance. Remove cap and pop out the pin that's attached
3. On the side you will see the pin position for use with LPG
4. Unscrew pin and flip it to the LPG position - short end outwards, spring on outside.



NG

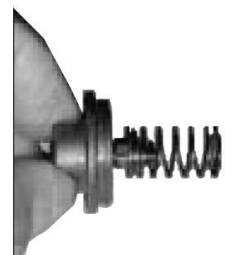

LPG

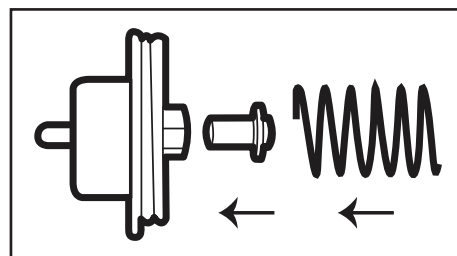

## GAS RANGE CONVERSION (continued)

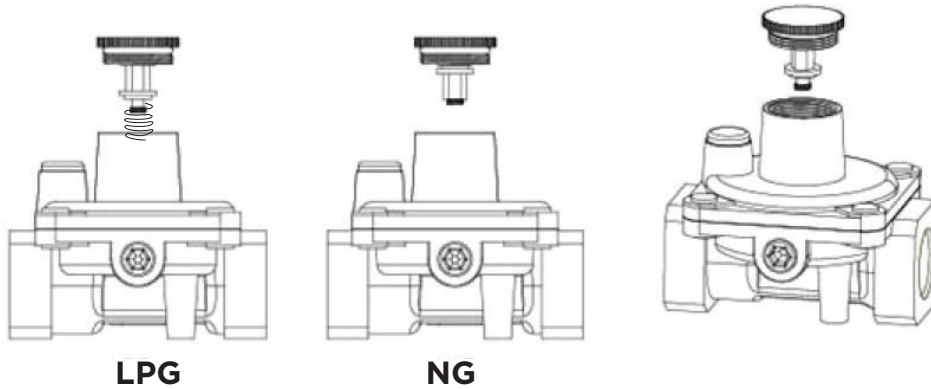

5. Replace the cap back on the regulator
6. Remove the grates, burners and burner caps from the range to access the orifices.
7. Use a 7 mm wrench to remove the orifices. Each orifice can be accessed easily - the larger burner orifice is located on the burner wall.

### BURNER ORIFICE

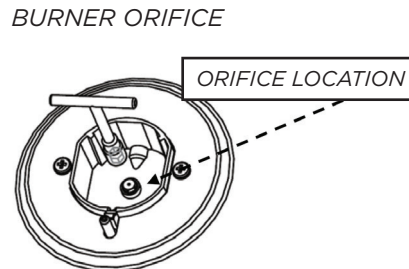

8. Remove all NG orifices, place in the bag and store in a safe place.
9. Take the LPG orifices provided and install them as shown below.

See below for rating of orifice for each model

	<b>Front Right</b>	<b>Rear Right</b>	<b>Front Left</b>	<b>Rear Left</b>	<b>Oven</b>	<b>Broil</b>
LPG	0.53 mm	1.00 mm	0.9 mm	0.68 mm	0.82 mm	0.8 mm

10. Once all the orifices are installed, replace all burners and burner caps, then fire up the burners to check the minimum flame height.

## GAS RANGE CONVERSION (continued)

### To replace the oven burner orifice

1. Remove the back panel
2. Locate/disconnect oven orifice housing screws x 2 (Fig 1)
3. Gently bend gas tube to gain access to the orifice
4. Use a 7 mm socket to remove orifice and replace with specified orifice for gas conversion
5. Remount oven orifice housing screws x 2

### To replace the broiler burner orifice

1. Locate/disconnect broil orifice housing screws x 2
2. Gently bend gas tube to gain access to the orifice (Fig 2)
3. Use a 7 mm socket to remove orifice and replace with specified orifice for gas conversion
4. Remount broil orifice housing screws x 2
5. Replace back panel

Note: Check for leaks using a leak detector or soapy water with recommended ratio of 75% water, 25% dish washing soap. Once you have completed the conversion, check the operations of ignition making sure each of the 4 burners, pilot flame and oven burner flame are functioning correctly. Please refer to pages 30 through 35.

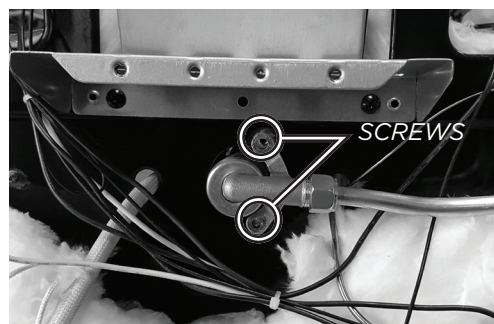
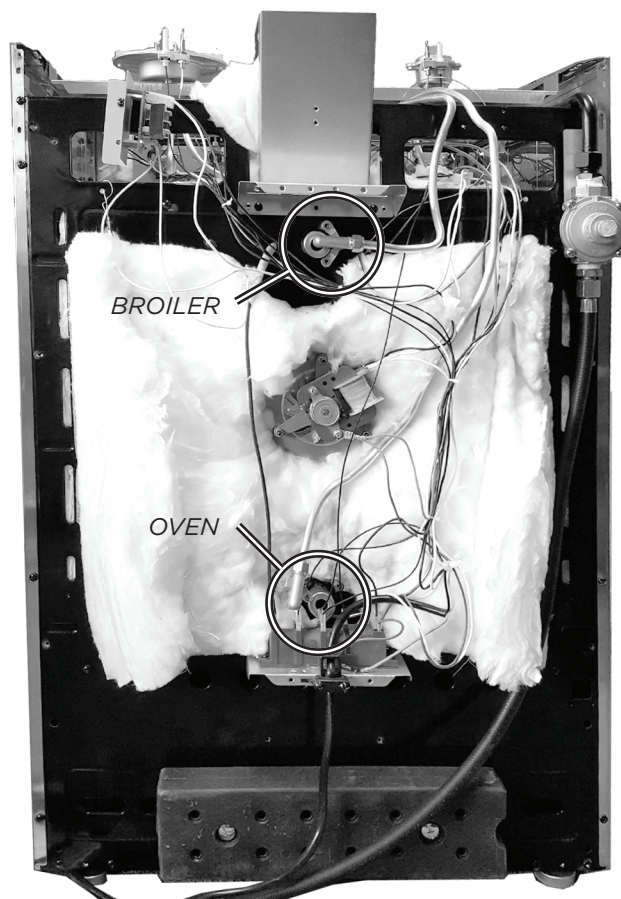

FIG 1. OVEN

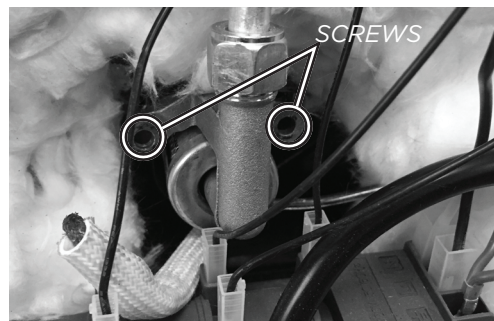

FIG 2. BROILER

## GAS RANGE CONVERSION (continued)

### CHECKING FOR MANIFOLD GAS PRESSURE

To check the manifold gas pressure, remove the burner cap and connect a manometer (water gauge) or other pressure test device to the burner orifice. Use a rubber hose with inside diameter of approximately ¼" hold the end of the hose tight over the orifice. Turn the gas valve on. For a more accurate pressure check, have at least two (2) other top burners burning. Be sure that the gas supply (inlet) pressure is at least one inch above the specified manifold pressure. Maximum gas supply pressure must not exceed 14" inch water column, minimum gas supply pressure must be 1" inch water column above recommended pressure, 12" for propane gas, and 5" water column for natural gas. When properly adjusted the manifold water column pressure is 10" for LP/propane gas or 5" for natural gas.

**Note:** Once the unit has been converted fill out the included sticker and place it on the back of the range

Once you have completed the conversion, check the operations of ignition making sure each of the 4 burners, pilot flame and oven burner flame are functioning correctly. Please refer to pages 30 thru 35 - Operation of Range.

This appliance was converted on \_\_\_\_\_ (day-month-year) to \_\_\_\_\_ (insert gas type; e.g. Natural or Propane) gas with Kit No. \_\_\_\_\_ by \_\_\_\_\_ (name and address of organization making this conversion), which accepts the responsibility that this conversion has been properly made.

**High Altitude Applications above 2,000 feet:** At elevations above 2,000 feet, the range must be derated 4% for each 1,000 feet above sea level. It is the installer's responsibility to see that the range's input rate is adjusted properly.



# ADJUSTING THE TOP BURNER AND OVEN FLAME



Keep appliance area clear and free from combustible materials, gasoline, and other flammable vapors and liquids. Do not obstruct the flow of air that is necessary for combustion and ventilation.

## TOP BURNER VALVES

The top burners have orifices that are dedicated to the type of fuel to be used. These orifices are not adjustable. They must be changed completely to convert from one gas to the other. DO NOT DISCARD THE UNUSED ORIFICES. They should be saved in order to convert the range back to its original fuel.

When converting the gas valves, the minimum flame adjustment screw must be adjusted.

Please see the supplied screwdriver in the conversion kit along with the orifices. The proper flame size is approximately ¼" obtained. – see adjustment procedure below.

The properly adjusted maximum flame is approximately ¾" high and has three distinct cones; the kindling point, the dark blue center cone, and the outer mantel.

## ADJUSTING THE TOP BURNER FLAME

1. Ensure the range has gas supply and power
2. Light the burner
3. Set the top burner valve to the minimum position
4. Remove the knob by pulling straight out
5. Locate the bypass screw behind the left screw (see illustration)

Remove the left screw. Insert the flat head screwdriver (2.5 mm x 75 mm - provided) into the screw hole and turn the by pass screw clockwise to adjust the flame.

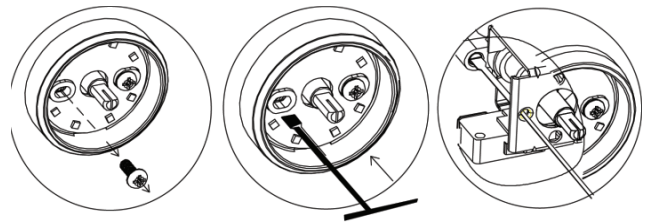

Do not overtighten.

6. Replace the knob
7. Repeat for each of the other burners

# ADJUSTING THE TOP BURNER AND OVEN FLAME (continued)

## COOKTOP BURNER OPERATION

The top burner flame size should be adjusted so that it does not extend beyond the edge of the cookware. As a matter of safety, it's recommended that you comply with these instructions.

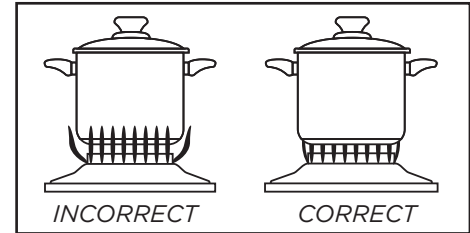

A high flame on a surface burner is both inefficient and unsafe. The flame should always be adjusted so that it is no larger than the bottom of the pan. Fluctuations in flame size could be caused by pressure variations, improperly positioned burners, damage or debris.

To light a burner, press the burner knob in and turn counter clockwise to high flame/ignition position. You will hear the electronic ignition clicking as you continue to hold the knob down until the flame lights. ALL electrodes will spark at a rate of approximately 2½ pulses (sparks) per second. Continue to hold the knob depressed until gas ignites at the burner. Adjust the intensity of top burner heat in the same manner described above.

**Note:** In the event the electronic ignition system fails, the top burners and oven pilot can be lit by holding a lighted match near the burner head and turning the appropriate top burner knob to the “9 o'clock position”.

## Top Burner Height

### INCORRECT AND GOOD FLAME PATTERNS

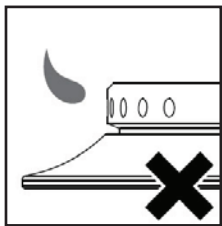

**Incorrect:** flame lifting off the burner

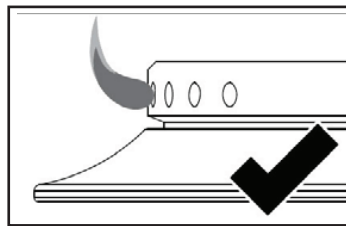

**Good flame:** Well-defined blue flame with slight yellow tipping

### QUALITY OF FLAMES

The combustion quality of burner flames needs to be confirmed visually.



A. Yellow flames — Call for service



B. Yellow tips on outer cones — It is normal for LP gas



C. Soft blue flames — It is normal for natural gas

If burner flames look like A, call for service.

B or C is normal burner flames, depending on the type of gas you use.

With LP gas, some yellow tipping on outer cones is normal.



## ADJUSTING THE TOP BURNER AND OVEN FLAME (continued)

**TIP: Before proceeding, take note of the original burner bypass screw placement.**

### ADJUSTING THE OVEN BURNER FLAME

- 1) Light the burner by turning the thermostat to the 500°F position,
- 2) Remove the knob by pulling straight out.
- 3) Remove the two (2) Phillips head screws that secure the bezel to the control panel.

- 4) Carefully lift the bezel away from the control panel to allow access to the access hole below the valve stem. (see illustration).

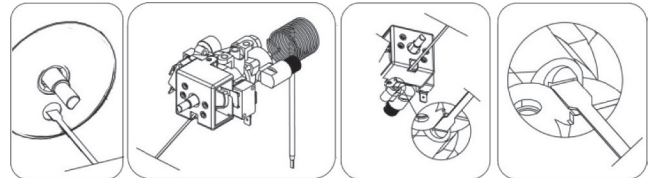

- 5) Insert the flat head screwdriver (2.5 mm x 75 mm) into the screw hole and turn the bypass screw clockwise to adjust the flame.

DO NOT OVERTIGHTEN.

- 6) Mount the knob to the valve stem.
- 7) Allow the oven to heat up for approximately 10 minutes then rotate the knob to the 300°F position to operate the thermostat by-pass. Slowly screw the by-pass screw until you obtain a flame of approximately 3 – 4 mm in height.
- 8) Carefully replace the bezel and knob ensuring not to damage wires.

### OVEN VALVE

The oven control has a flame safety device built into the body of the thermostat.

Presence of a gas ignition source (pilot) is verified by a flame safety probe. This flame safety probe actuates the internal safety device to allow gas into the oven burner when the oven is turned on. If there is a loss of gas ignition during operation, the flame safety device will close off gas flow to the oven burner and pilot.

The oven burner orifice is located on a brass injector stud at the rear of the oven under the oven floor. This orifice is dedicated to the gas for which the oven is to be used. The orifice is not adjustable. It must be changed completely to convert from one gas to the other. **DO NOT DISCARD THE UNUSED ORIFICE.** It should be saved in order to convert the range back to its original fuel

## OPERATION OF RANGE



	Off	OFF
	Push & rotate left to ignite oven	PUSH ⚡
	Burner position	●
	Oven	▣
	Push & rotate right to ignite broiler	BROIL ⚡

### LIGHTING THE TOP BURNERS

1. To obtain a flame more easily, light the burner before placing a cooking utensil on the burner grate.
2. Decide which burner you're igniting first using the screened diagram below the burner knob. The black dot indicates the position of the burner you're igniting.
3. To light a burner, press the burner knob in and turn counter clockwise to high flame/ignition position. You will hear the electronic ignition clicking as you continue to hold the knob down until the flame lights.
4. After lighting the flame, turn the control knob to adjust the flame size as required.

### CHOICE OF BURNER

#### DIAMETERS OF PANS WHICH MAY BE USED ON THE TOP BURNERS

BURNER	MINIMUM	MAXIMUM
Auxiliary	4.72" (12 cm)	5.5"(14 cm)
Semi-rapid	6.29" (16 cm)	9.44" (24 cm)
Rapid	9.44" (24 cm)	10.23" (26 cm)
<b>Do not use pans with concave or convex bases</b>		

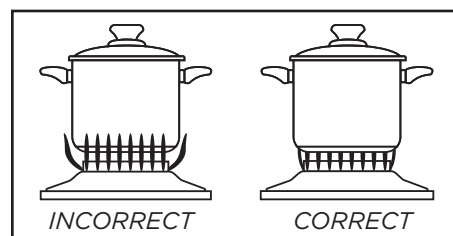

## OPERATION OF RANGE (continued)

### HOW TO USE THE GAS OVEN

#### **General features**

The gas oven is provided with two burners:

The Oven burner, mounted on the lower part of the oven

The Broil burner, mounted on the upper part of the oven

#### **Using the oven for the first time**

It is advised to follow these instructions:

- Insert shelves and broiler grid and tray
- Turn the oven on to the maximum temperature position (500°F) to eliminate possible traces of grease from the oven burner. The same operation should be followed for the Broil burner (knob on position BROIL).
- Unplug the power cord, let the oven cool down, then clean the interior of the oven with cloth soaked in water and detergent (neutral) then dry carefully.

### OVEN BURNER

Performs the normal “oven cooking” function.

- The gas flow to the burner is regulated by a thermostat which maintains the desired oven temperature.
- The control of the temperature is determined by a thermostatic probe positioned inside the oven.
- The probe must be always kept in its housing, in a clean condition, as an incorrect position or a dirty probe may cause improper control of the temperature.

### GAS OVEN SETTING

Number printed on the knob (temperature in °F)	Corresponding temperature in °C
300	149
350	177
400	204
450	232
500	260



### OVEN THERMOSTAT

- The numbers printed on the control panel indicate the increasing oven temperature value (°F).
- To regulate the temperature, set the chosen number onto the control knob indicator.
- The position BROIL serves only to turn on the broil burner.

**Note:** When the range will not be used for long periods of time, set the gas knobs to their OFF

## OPERATION OF RANGE (continued)

positions and also close the gas shut-off valve placed on the main gas supply line.



**VERY IMPORTANT: The oven/broil shall be used always with the door closed.**

**VERY IMPORTANT:** Never obstruct the oven vent slots on the backsplash.

- **Important:** Use always suitable protective gloves when inserting/removing the broiling pan, shelves, pans on other cooking utensils from the oven.
- **Attention:** the range becomes very hot during operation
- **Attention:** the oven door becomes very hot during operation; be sure to use the handle to open/close.
- Keep children away from the stove/oven when it is in use.

### IGNITION OF THE OVEN BURNER

The thermostat allows the automatic control of the temperature.

The gas delivery to the oven burner is controlled by a two way thermostatic tap (oven and broil burners) with flame-failure device.

**To light the oven burner operate as follows:**

1. Open the oven door to its full extent.



**WARNING: Risk of explosion! The oven door must be open during this operation.**

2. Lightly press and turn the thermostat knob counter-clockwise to max position or 500°F.
3. Press the knob inward and hold to activate the electronic ignition. Note that you will hear a “clicking” noise. Hold the knob pressed inward until the oven burner is lit. Once the oven burner is lit, release the knob.

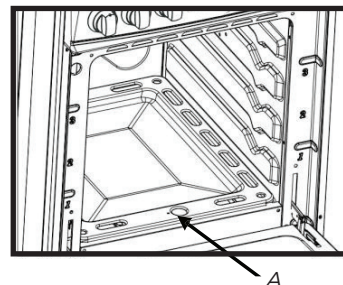
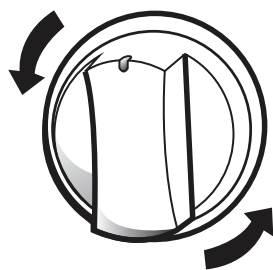

In case of power outage, you can manually light the burner by pressing the knob inward and immediately approach a lighted match to the opening “A” (see the diagram above).



**Never continue this operation for more than 15 seconds. If the burner has still not ignited, wait for about 1 minute prior to repeating the ignition.**

4. When using the range for the first time or after long period of non-usage, keep pressing the knob inward for approximately 10 - 15 seconds after the burner has lit to ensure the gas valve has been accurately primed.
5. Close the oven door slowly and adjust the burner accordingly to the desired temperature. If the flame extinguishes for any reason, the safety valve will automatically shut off the gas supply to the burner.

To re-light the burner, first turn the oven control knob to the OFF position, wait for at least 1 minute and then repeat the lighting procedure.

**Attention: the oven door becomes very hot during operation. Keep children away.**

## OPERATION OF RANGE (continued)

### MOISTURE IMPORTANT

If sparking does not occur when the oven thermostat knob is turned on during the initial attempt to use, or after several days of non-use, it COULD BE the result of moisture build-up in the ceramic sleeve of the oven electrode. This may happen in areas with high humidity, or if food having high water content is cooked. This moisture can be driven out of the ignitor by lighting the pilot and operating the oven for a few minutes.

### CONVECTION MODE

Heat is transferred from the bake burners in the bottom of the oven cavity to the oven cavity itself. The convection fan in the rear of the oven then circulates the hot air, providing even heat distribution throughout the oven. Convection cooking generally provides a more even temperature with faster baking times than the standard oven baking setting. This mode is controlled by a switch on the right hand side of the control panel. Simply flick the switch in to activate it.

- Position the oven's bottom cover and the oven shelf/shelves before using the oven. Use more than one oven shelf for larger baking loads. Remove any unused shelves and baking utensils from the oven.
- Preheat the oven to the temperature stated in the recipe before baking. Depending on the temperature needed and the size of the oven, preheating will take 15 - 20 minutes.
- Arrange pans and food items evenly on the shelves. Make sure pans do not touch each other or the sides of the oven. When baking a single item, always center the item on the oven shelf, preferably in the center of the oven. If baking on multiple shelves, make sure to stagger items on the shelves so that one is never directly above another.

### NOTES ABOUT CONVECTION COOKING

Convection cooking generally provides a more even temperature with faster baking times than the standard oven baking setting. When baking in Convection Mode, either reduce the temperature stated in the recipe and leave the baking time unchanged, or reduce the baking time by several minutes and leave the temperature unchanged. For foods with a baking time of over an hour, reducing both the temperature and the time slightly may give the best results.

- Dark metal baking pans or those with a dull finish absorb heat faster than shiny pans, and are excellent for pies, breads and anything that needs browning or a crisper crust.
- Shiny finish or light coloured pans may work best for foods that require lighter, more delicate browning or a crisper crust as they reflect some heat, creating a less intense baking surface.
- Avoid opening the oven door frequently during baking as this affects temperature and efficiency.

## OPERATION OF RANGE (continued)

### CONVECTION ROASTING

When convection roasting, it is important that you use a broiler pan for best convection roasting results. A broil/roast pan (with a rack) elevates the roast to allow the hot air to circulate around the meat, sealing in juices for a moist and tender roast with a richly browned exterior (similar to a rotisserie effect.) The pan is also used to catch any drippings from the roast, keeping the oven clean and reducing the chance of smoking or flare-ups. The convection fan circulates heated air evenly over and around the food, sealing in juices for a moist and tender roast with a richly browned exterior.

### CONVECTION DEFROST

With the temperature control off, a motorized fan in the rear of the oven circulates air. The fan accelerates natural defrosting of the food without heat. To avoid bacteria growth, food-borne illness and food waste, do not allow defrosted food to remain in the oven for more than 2 hours without being cooked.

### CONVECTION DEHYDRATE

With the temperature control at 175°F, warm air is radiated from the bake burners in the bottom of the oven cavity and is circulated by a motorized fan in the rear of the oven. Over time, this constant circulating heat evaporates moisture from food, which inhibits bacteria growth and halts enzyme activity

**NEVER LEAVE THE CONTROL KNOBS IN ANY POSITION OTHER THAN “OFF” IF THE IGNITORS OR BURNERS AREN’T WORKING PROPERLY.**

### IGNITION OF THE BROIL BURNER

To light the broil burner operate as follow:

1. Open the oven door to its full extent.  
**WARNING: Risk of explosion! The oven door must be open during this operation.**
2. Lightly press and turn the thermostat knob clockwise to the broil position.
3. Press the knob inward and hold to activate the electronic ignition. Note that you will hear a “clicking” noise. Hold the knob pressed inward until the oven burner is lit. Once the oven burner is lit, release the knob. In case of power outage, you can manually light the burner by pressing the knob inward and immediately approach a lighted match to the area noted in the diagram above.

Never continue this operation for more than 15 seconds. If the burner has still not ignited, wait for about 1 minute prior to repeating the ignition.

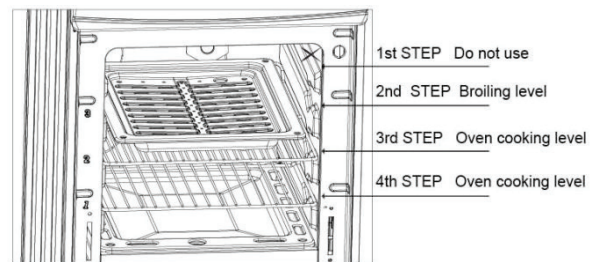
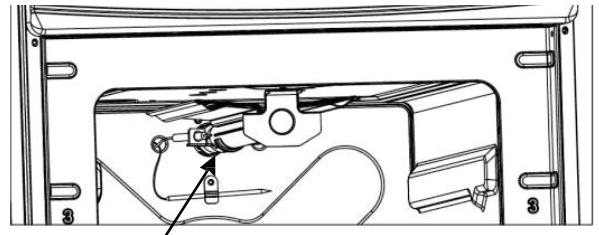



## OPERATION OF RANGE (continued)

4. When using the range for the first time or after long period of non-usage, keep pressing the knob inward for approximately 10 - 15 seconds after the burner has lit to ensure the gas valve has been accurately primed.
5. Slowly close the oven door. If the flame extinguishes for any reason, the safety valve will automatically shut off the gas supply to the burner.

To re-light the burner, first turn the oven control knob to the  position, wait for at least 1 minute and then repeat the lighting procedure.

**Always broil with oven door closed. Attention: the oven door becomes very hot during operation. Keep children away.**

### BROILING

**Very important: the broil burner must always be used with the oven door closed.**

Position the oven rack on the second level from the top

1. Turn on the broil burner, as explained in the preceding paragraphs and let the broil burner preheat for about 5 minutes with the door closed.
2. Place the food to be cooked below the broiler.

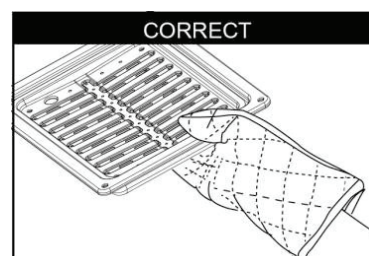
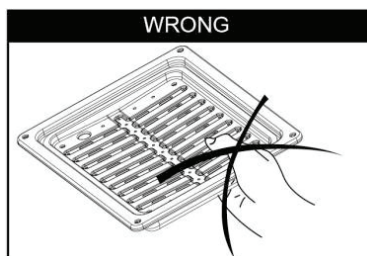
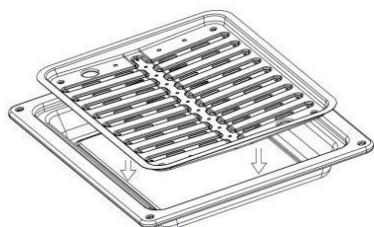

### OVEN LIGHT

The range is equipped with a light that illuminates the oven to enable visually controlling the food that is cooking. This light is controlled by a switch on the left hand side of the control panel. Simply flick the switch to activate the light.

### CHANGING OVEN LIGHT BULB

Remove light bulb cover and unscrew light bulb counter clockwise. Replace with an E14 120V 25W 300°C bulb.

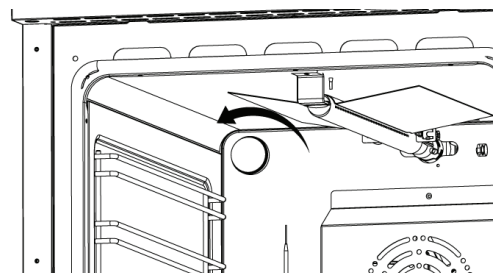

# CLEANING THE RANGE

## GENERAL RECOMMENDATION



**WARNING**



### Electrical Shock Hazard

- Plug into a grounded 3-prong outlet. Insure proper ground exists before using the range.
- Do not remove ground prong.
- Do not use an adapter or extension cord.
- Failure to follow these instructions can result in death, fire, or electrical shock.

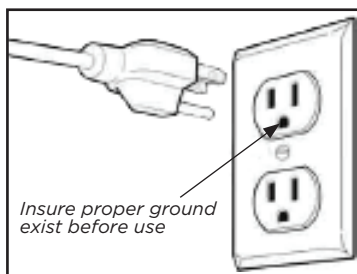

## **WARNING**



### **Electrical Shock Hazard**

Plug into a grounded 3-prong outlet.  
Do not remove ground prong.  
Do not use an adapter.  
Failure to follow these instructions can result in death, fire, or electrical shock.

**Important:** Before any operation of cleaning and maintenance disconnect the appliance from the electrical supply.

It is advisable to clean when the appliance is cold and especially for cleaning the enameled parts.

Avoid leaving alkaline or acidic substances (lemon juice, vinegar, etc.) on the surfaces. Avoid using cleaning products with a chlorine or acidic base.

The oven must always be cleaned after every use, using suitable products and keeping in mind that its operation for 30 minutes on the highest temperature eliminates most grime reducing it to ashes.

Always keep cleaning materials and chemicals in a safe place and away from children. Know what you are using. Make sure all parts of the range are COOL before cleaning. Be sure to replace the parts correctly.

## **Knobs**

Pull forward on the knobs to remove them. Wash in a water solution with a mild detergent mix. Do not use an abrasive cleaner or any abrasive action. Abrasive action will scratch the knobs.

If the knobs become loose on the valve stem, spread the valve stem slightly with a small screwdriver.

## **Using Commercial Oven Cleaners**

Commercial oven cleaners may be used on porcelain lined ovens; however, many cleaners are very strong, and it's essential to follow instructions carefully. Be sure to wear rubber gloves to protect your hands.

After using such cleaners, thoroughly rinse the oven with a solution of 1 tablespoon vinegar to 1 cup of water. Oven cleaners can coat or damage the thermostat sensing device (the long tube in the oven) so that it will not respond to temperature accurately. If you use an oven cleaner, do not let it contact the sensing bulb, or any chrome, aluminum, or plastic part of the range.

**Do not apply or allow the cleaner to come in contact with any parts or surfaces other than the oven interior.**



## CLEANING THE RANGE (continued)

### Grates, Main Tops, Surface Burners

The grates are made of porcelain coated steel. These materials can be cleaned at the sink with detergent or soap-filled scouring pads. Do not be alarmed when the grate loses its shiny finish. The heat from the burners will cause the grates to lose their shiny finish.

Clean the burner with soap and water, rinse thoroughly and dry completely before reassembling. Burner heads can be dried in the oven at about 350 degrees Fahrenheit or in the dishwasher on the dry cycle. After adjustment or cleaning, replace all parts to their original position.

### Stainless Steel Elements

The stainless steel finish top can be cleaned with detergent and warm water.

Stainless steel parts must be rinsed with water and dried with a soft and clean cloth or with a chamois leather.

For difficult grime, use a commercially available, non-abrasive product for cleaning stainless steel surfaces, or a little hot vinegar.

**Note:** Regular use could cause discoloring around the burners, because of the high flame temperature.

Products of combustion from the top pilots as well as certain atmospheric conditions can create an oxidation reaction on the underside of the top. This will appear as rust or in the form of a reddish brown deposit. This will NOT AFFECT THE LIFE OF THE TOP in comparison to the general life expectancy of the range itself.

It is very important that the burner be dry before replacing it in the range. A wet burner will not allow the gas to ignite properly. This could result in a build-up of gas which could result in an explosion or fire.

# CARE AND MAINTENANCE

## ALUMINUM FOIL IN OVEN



**WARNING**



**NEVER cover any slots, holes or passages in the oven bottom or cover an entire rack with materials such as aluminum foil. Doing so blocks air flow through the oven and may cause carbon monoxide poisoning. Aluminum foil linings may also trap heat, causing a fire hazard.**

Aluminium foil when used improperly is a cause of many range fires. Make certain that vents or air openings aren't covered by the foil. If the vents located along the sides of the oven bottom are blocked, poor cooking will result.

Never cover a rack completely. A piece of foil slightly larger than the cookware can be placed on the rack beneath the cookware.

Remove and discard aluminum foil after each use. This will help prevent grease and spilled food from accumulating and becoming a fire hazard.

## CLEANERS AND CLEANING MATERIALS

Do not use harsh cleaners or degreasers on or around functional parts (valves, controls, etc., or aluminum tubing). This will damage or drastically reduce the life of the part.

Use only a mild solution of soap and water on backguards, aluminum control panels and painted surfaces. Never use harsh abrasives or cleaning powders that may scratch or mar the surface. Make sure the cleaners and cleaning materials are suitable for use on the area to be cleaned. Always keep cleaning materials in a safe place. Never use a sharp metal scraper to clean glass, porcelain, or painted surfaces.

## REPAIR PARTS

When repair parts are needed, contact the dealer from whom the range was purchased. In case your range was purchased from a source other than an appliance dealer, you may prefer to contact the manufacturer at the address shown in this manual.

## MOISTURE

During the initial heat-up of your range, the heat mixing with the cooler air in the oven cavity may produce fogging of the door glass or a collection of water on the door. To prevent this, open the oven door for the first few seconds of initial oven heat-up. This will allow the moist air within the oven to escape, without the forming of visible moisture on the range. The amount of moisture will depend upon the humidity of the air and water content of the food being cooked. Fogging and even dripping water will usually occur in geographic locations of high humidity.

## CARE AND MAINTENANCE (continued)

### BURNERS AND CAST-IRON GRIDS

- These parts can be removed and cleaned with appropriate products.
- After cleaning, the burners and their flame distributors must be well dried and correctly replaced.
- It is very important to check that the burner flame distributor and the cap has been correctly positioned - failure to do so can cause serious problems.
- In appliances with electric ignition keep the electrode clean so that the sparks always strike.

**Note: To avoid damage to the electric ignition do not use it when the burners are not in place.**

### CORRECT REPLACEMENT OF THE BURNERS

It is very important to check that the burner flame spreader "F" and the cap "C" have been correctly positioned. Failure to do so can cause serious problems. In appliances with electric ignition, check that the electrode "S" is always clean to ensure trouble-free sparking.

**The ignition plug must be cleaned very carefully.**

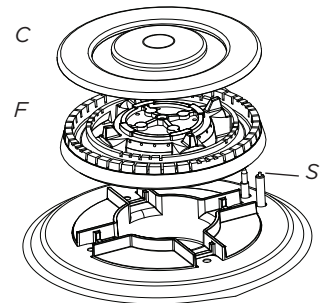

### OVEN RACK INSTALLATION AND REMOVAL

- The oven racks are provided with a safety catch to prevent accidental removal.
- They must be inserted as shown.
- To pull them out remove the rack in the reverse order.

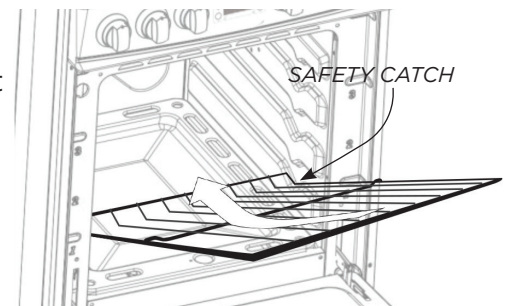

### REMOVABLE STORAGE DRAWER

1. Lift the left small hook upward, at the same time, push the right small hook downward. (see the picture)
2. Pull the drawer out.
3. To replace the drawer, align the drawer with the rails and push inward.

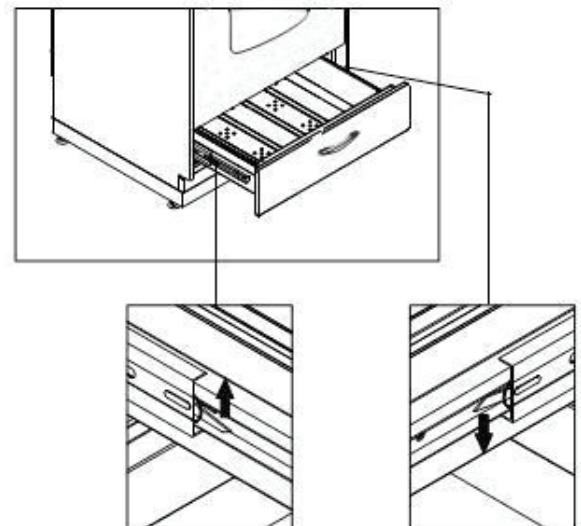

**DO NOT STORE FLAMMABLE MATERIAL IN THE OVEN OR IN THE BOTTOM DRAWER.**

## CARE AND MAINTENANCE (continued)

### REMOVING THE OVEN DOOR FOR CLEANING

To facilitate oven cleaning, it is possible to remove the door. Please follow the instructions carefully:

#### The oven door can easily be removed as follows:

- Open the door to fully.
- Lift the left and right hooks on the hinge figure (A,B).
- Hold the door as shown in figure (C) on a 45 degree angle.
- Gently close the door until the hooks touch the door, then lift at a 45 degree angle
- Set the door on a soft flat surface.
- To replace the door, repeat the above steps in reverse order.

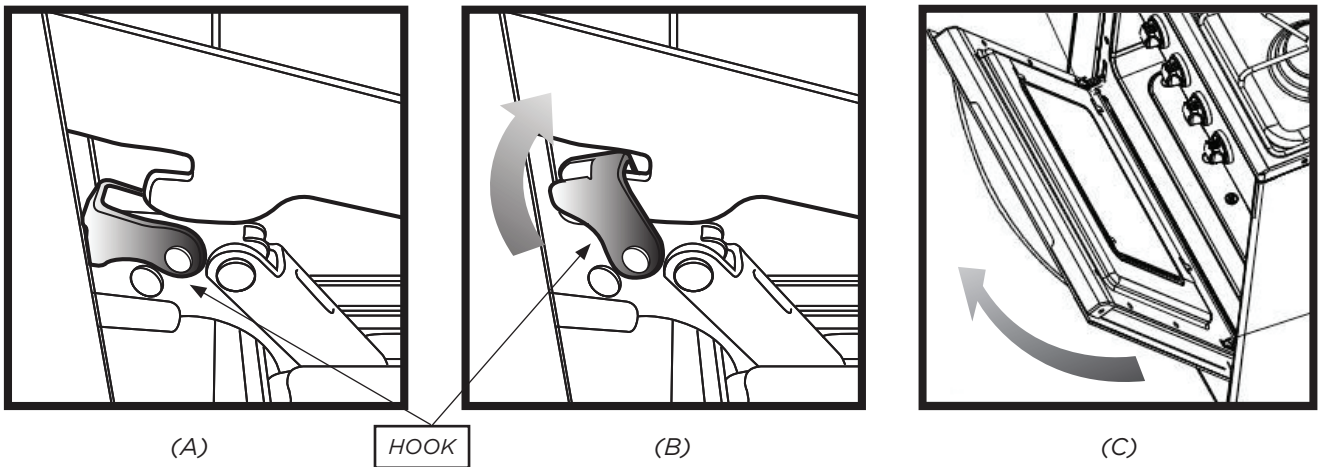

## CARE AND MAINTENANCE (continued)

### REPLACING THE OVEN LIGHT

- Let the oven cavity and broil burner cool down.
- Switch off the electric supply.
- Remove the protective cover.
- Unscrew and replace the bulb with a new one suitable for high temperature (200°~500°F) having the same specifications: 120V 60Hz, 15W, E14.
- Replace the protective cover.

**NOTE:** Oven bulb replacement is not covered by your guarantee.

### LEVELING THE RANGE

The range must be level to obtain proper operating. The four screws type leveling legs located on the corners at the bottom of range should be adjusted by turning them clockwise to make the range higher or counter-clockwise to lower the range until the range is level. Use a level on surface units to check the leveling of the range.

### ANTI-TIP BRACKET INSTALLATION

To reduce the risk of tipping the range by abnormal usage or improper door loading, the range must be secured by properly installing the anti-tip device packed with the appliance.

- Place the anti-tip bracket on the floor as shown figure. Anti-tip bracket can be installed on the right and left side.
- Make the locations of 2 (x2) holes of ant-tip bracket on the floor.
- Use a drill bit
- Secure bracket to floor using screws supplied.
- Slide appliance into position.

**NOTE:** If range is relocated, the bracket must be removed and installed in new location.

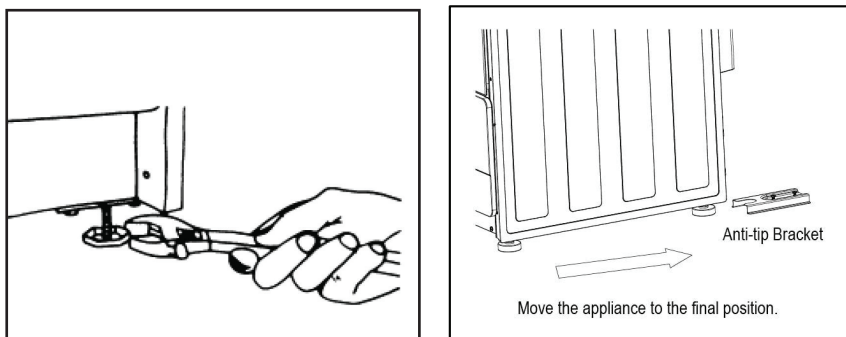

## TROUBLESHOOTING

PROBLEM	POSSIBLE CAUSE	POSSIBLE FIX
Surface burners do not light.	Surface control has not been completely turned to the ON position.	Push in and turn control to the ON position until burner ignites, then turn control to desired flame setting.
	Burner ports are clogged.	Use a small gauge wire or needle to open ports.
	Burners not positioned properly.	Verify that the burners are positioned properly on the orifice hoods and the burners are sitting flat on the burner support with tabs engaged in slots.
	Range not set for appropriate gas input.	See range conversion section of installation manual.
	Burners won't light due to power failure.	Light burners manually.
	Range power cord is disconnected from the outlet.	Be sure power cord is plugged into grounded outlet.
Flame burns halfway round.	Burner ports are clogged.	Use a small gauge wire or needle to open ports.
	Moisture is present after cleaning.	Lightly fan the flame and allow burner to operate until flame is full. OR dry burners thoroughly following instructions in range "Cleaning" section.
	Range is not set for appropriate gas input.	See range conversion section of installation manual.
Flame is orange.	Dust particles in main line.	Allow burner to operate for a few minutes until flame turns blue.
	Range is not set for appropriate gas input.	See range conversion section of installation manual.
Oven light does not work.	Burned out or loose bulb	Tighten or replace oven light bulb.
Oven or broiler does not heat.	Range is not set for appropriate gas input.	See range conversion section of installation manual
	Temperature control not set properly.	Make sure temperature control is set at desired temperature.
	Burners will not light due to power failure.	Light burners manually.
	House fuse has blown or circuit breaker has tripped.	Check/reset circuit breaker and/or replace fuse. Do not increase fuse capacity. If the problem is a circuit overload, have it corrected by a qualified electrician.
	Range cord is disconnected from outlet.	Be sure the power cord is plugged into a grounded outlet.

## TROUBLESHOOTING (continued)

PROBLEM	POSSIBLE CAUSE	POSSIBLE FIX
Oven temperature is inaccurate.	Oven capillary bulb not positioned properly.	Verify that capillary bulb is snapped in clips straight and not touching sides or coated with oven cleaner or food.
	Temperature control not set properly.	Make sure the temperature control knob is set at the desired temperature.
	Improper use of foil.	Keep foil clear of holes in oven bottom and off of oven sides.
	Vent blocked.	Keep vent on backguard clear.
	Range not set for appropriate gas input.	See range conversion section of installation manual.
Smoke/odor on initial oven operation.	This is normal.	
Range is not level	Poor installation.	Place oven rack in centre of oven. Place a level on the rack. Adjust leveling legs.
	Weak or unstable floor.	Be sure floor is level and can adequately support range. Contact carpenter to correct sagging or sloping floor.
	Kitchen cabinet misalignment may make range appear to be unlevel.	Be sure cabinets are square and have sufficient room for range clearance. Contact cabinet maker to correct problem.
Oven smokes excessively.	Meat too close to broiler burner.	Reposition the broiler pan to provide more clearance between the meat and the broiler burner.
	Meat not prepared properly.	Remove excess fat from meat.

# WIRING DIAGRAM

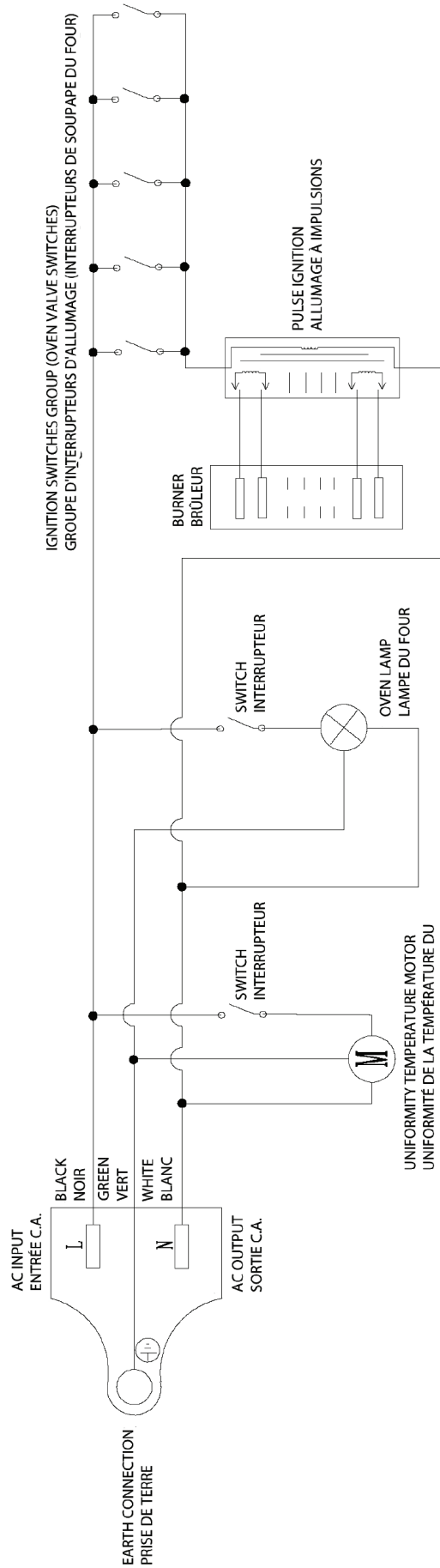



# PARTS DIAGRAM AND LIST

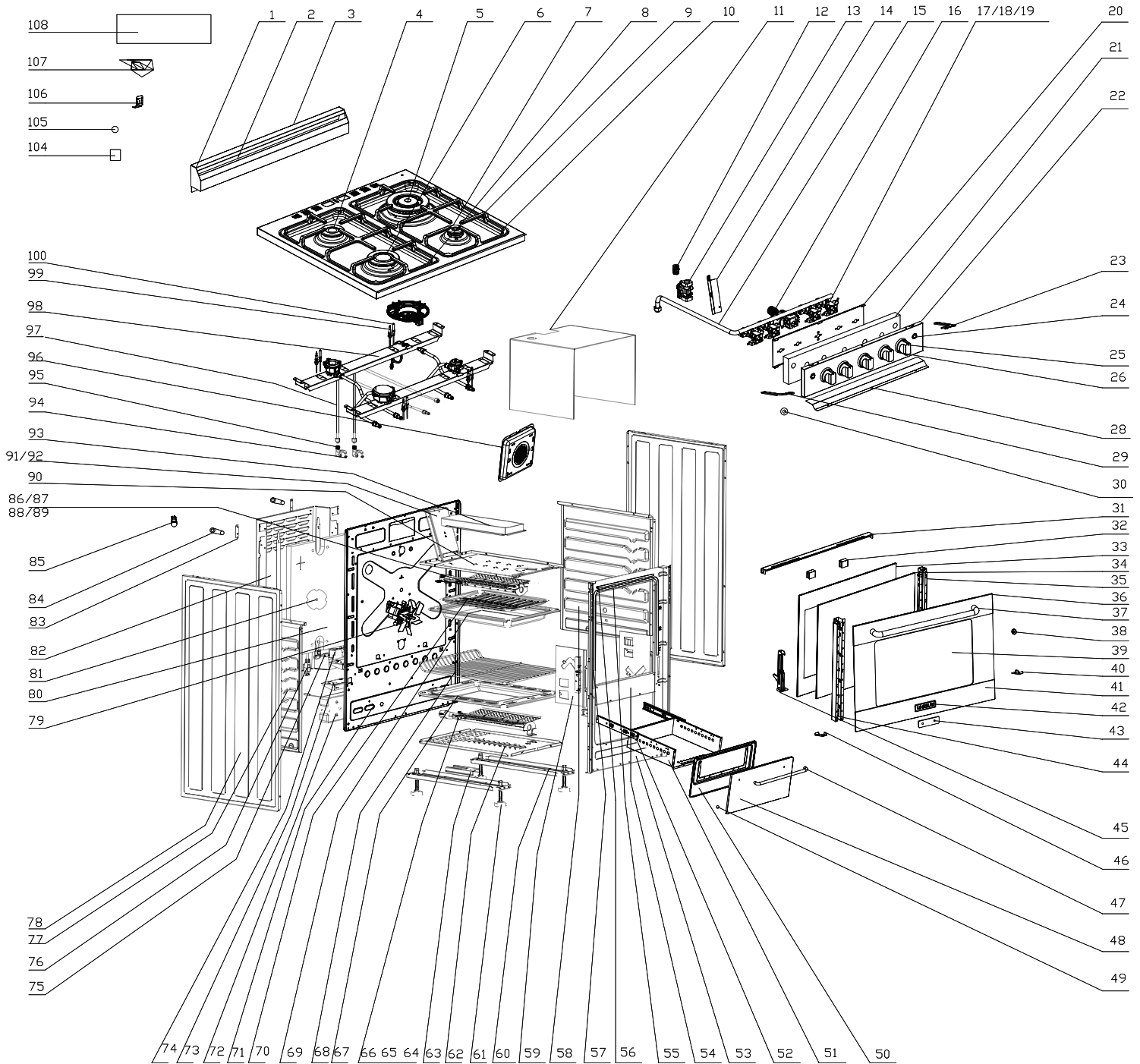

Please visit our website [www.uniqueappliances.com](http://www.uniqueappliances.com) to view a PDF version of the schematics which will allow you to zoom in & out

## PARTS DIAGRAM AND LIST

Item	# Description	Part #
1	Backsplash	UGP-G20H08-011600
2	Backsplash inner plate	UGP-G20H08-011700
3	Backsplash cover	UGP-G20H08-011500
4	75 burner	UGP-G20A02-040100
5	130 burner	UGP-G20A02-040300
6	100 burner	UGP-G20A02-040200
7	55 burner	UGP-G20A02-040000
8	Grates (left)	UGP-G20H08-021300
9	Grates (right)	UGP-G24C05-021600
10	Cooktop	UGP-G20H08-020100
11	Cavity heat insulation plate	UGP-C20B01-074500
12	Regulator adaptor	UGP-G24G02-034200
13	NG5 "LPG10" Regulator	UGP-G20C01-034002
14	Regulator support	UGP-G24G02-034500
15	Gas pipe	UGP-G20H08-030700
16	Thermostat	UGP-G20C02-030619
17	Valve-0.50	UGP-G20D02-030535
18	Valve-0.81	UGP-G20D02-030533
19	Valve-0.95	UGP-G20D02-030534
20	Control panel inside panel	UGP-G20H08-030400
21	Control panel insulation cotton	UGP-G20H08-036000
22	Control panel S/S	UGP-G20H08-030300
22	Control panel white	UGP-G20H08-030300-01
22	Control panel black	UGP-G20H08-030300-02
23	Control panel connection plate (right)	UGP-G20C01-022200
24	Switch ASM	UGP-G24H08-170200
25	Knob 19#	UGP-G20A19-030100-09
25	Knob #19 white	UGP-G20A19-030100-01
26	Knob ring (bezel)	UGP-G20A06-030200-10
28	Control panel strip	UGP-G20H08-214500
29	Control panel connection plate (left)	UGP-G20C01-022100
30	G1/2 gasket	UGP-G20A01-210500
31	Door top cover	UGP-G20B01-101401
32	Door glass shockproof	UGP-G20A01-103300
33	LOWE Inner glass door	UGP-G20H08-100500
34	LOWE Door inside window	UGP-G20H08-101100
35	Hinge Support(right)	UGP-G20B01-101300
36	Door frame (up) S/S	UGP-G20H08-020000
36	Door frame (up) white	UGP-G20H08-020000-01
36	Door frame (up) black	UGP-G20H08-020000-02
37	Handle	UGP-G20B11-101900
38	Handle gasket	UGP-G20B02-100700
39	Outer door glass	UGP-G20B01-100400-05
40	Door inside glass support(right)	UGP-G20B01-100900
41	Door frame (down) S/S	UGP-G20H08-020001
41	Door frame (down)white	UGP-G20H08-020001-01
41	Door frame (down) black	UGP-G20H08-020001-02
31-41	Complete door assembly S/S	UGP-G20H08-100400S/S
31-41	Complete door assembly white	UGP-G20H08-100400W
31-41	Complete door assembly black	UGP-G20H08-100400B

## PARTS DIAGRAM AND LIST (continued)

Item	# Description	Part #
42	Nameplate	UGP-GC0139-020010
43	LOGO gasket	UGP-G24F08-100800
44	Hinge Support (left)	UGP-G20B01-101200
45	Door hinge	UGP-G20B01-110001
46	Door inside glass support (left)	UGP-G20B01-100800
47	Handle	UGP-G20B11-101900
48	Drawer outside plate S/S	UGP-G20H08-120100
48	Drawer outside plate white	UGP-G20H08-120100-01
48	Drawer outside plate black	UGP-G20H08-120100-02
49	Drawer cushion gasket	UGP-G20A01-120900
50	Drawer inside plate S/S	UGP-E20F01-120200-04
50	Drawer inside plate white	UGP-E20F01-120200-01
50	Drawer inside plate black	UGP-E20F01-120200-02
51	Drawer bottom plate	UGP-G20C03-120500-02
52	Sliding rail component	UGP-G20A01-120700
53	Front plate	UGP-G20C01-070102
54	Front plate-Beam	UGP-G20A01-070200
55	Front plate retaining strip	UGP-G20B01-214500
56	Cavity sealing strip-1	UGP-G20G02-071200
57	Cavity sealing strip-2	UGP-G20C01-071200
58	Cavity right plate	UGP-G20A01-070500
59	Door hinge plate	UGP-G20C01-111100
60	Oven feet mounting plate	UGP-G20A01-071100
61	Oven feet	UGP-G20C01-071500
62	Burner mounting plate	UGP-G20C01-072100
63	Anti-tip bracket	UGP-G20A01-212500
64	Oven burner assembly	UGP-G20B01-080100
65	Oven burner plate	UGP-G20A01-080900
66	Oven burner spark plug	UGP-G20C01-170502
67	Oven floor	UGP-G20A01-070700
68	Oven rack	UGP-G20H08-071900
69	Broil tray	UGP-G20C01-215000
70	Broil grill	UGP-G20C01-215100
71	Back plate	UGP-G20C01-070303
72	(12.5Kg) Weight Block	UGP-UGP-G20A01-210200
73	Regulator fixed part	UGP-G20C01-034500
74	120V Ignitor	UGP-G20C01-170106
75	Power fixed parts	UGP-G20A01-160200
76	Power Cord	UGP-G20A07-160105
77	Cavity left plate	UGP-G20A01-070400
78	0.5 Side plate S/S	UGP-G20C01-071002
78	0.5 White	UGP-G20C01-071002-01
78	0.5 Black	UGP-G20C01-071002-02
79	120V Temperature fan	UGP-G20A01-091501
80	Back insulation cotton	UGP-G20C01-072900
81	Temperature fan baffle	UGP-C36A01-073100
82	Baffle plate	UGP-G20C01-072000
83	Cooktop back connection plate	UGP-G20C01-022000
84	Support between wall and unit	UGP-G20C01-212600
85	120V 15W Oven lamp	UGP-G20C01-180101

## PARTS DIAGRAM AND LIST (continued)

Item	# Description	Part #
86	Top burner assembly	UGP-G20C01-090100
87	Top burner plate	UGP-G20C01-090300
88	Top burner infrared network	UGP-G20C01-090500
89	Grill burner spark plug 540	UGP-G20C01-170500
90	Cavity top plate	UGP-G20C01-070601
91	Chimney (with hole)	UGP-G20C01-074101
92	Chimney (no hole)	UGP-G20C01-074100
93	Diversion Plate	UGP-G20C01-075000
94	NG Injector (0.73)	UGP-G20A01-021208
	LPG Injector (0.53)	UGP-G20A01-021200
	NG Injector (1.0)	UGP-G20A01-021206
	LPG Injector (0.68)	UGP-G20A01-021201
	NG Injector (1.3)	UGP-G20A01-021213
	LPG Injector (0.9)	UGP-G20A01-021203
	NG Injector (1.5)	UGP-G20A01-021227
	LPG Injector (1.0)	UGP-G20A01-021206
	Top burner NG injector (1.24)	UGP-G20A01-021212
	Top burner LPG injector (0.8)	UGP-G20A01-021202
	Oven burner NG injector (1.3)	UGP-G20A01-021213
Oven burner LPG injector (0.82)	UGP-G20A01-021204	
95	Nozzle mount part	UGP-G20A01-021100
96	Temperature fan cover	UGP-G20H08-091700
97	Left/back pipe assembly	UGP-G24H08-022300
	Right/back pipe assembly	UGP-G24H08-022600
	Left/front pipe assembly	UGP-G24H08-022500
	Right/front pipe assembly	UGP-G24F08-022500
	Oven burner asm-burner pipe	UGP-G24H08-023100
	Top burner asm-burner pipe	UGP-G20C01-023300
98	Burner cup mounting plate	UGP-G20H08-024200
99	Spark plug 1100	UGP-G24A01-170401
	Spark plug 1050	UGP-G20A01-170406
	Spark plug 900	UGP-G20A01-170405
	Spark plug 680	UGP-G20A01-170404
100	Thermocouple 300mm	UGP-G20A01-030900
	Thermocouple 500mm	UGP-G20A01-030901
	Double ring Thermocouple	UGP-G24A01-031000
	Thermocouple	UGP-G20C01-072400
104	Spark plug-retainer	UGP-G20A01-170600
105	Wire connectors	UGP-G20A01-160300
106	Door glass support	UGP-G20A10-100900
107	Harness	UGP-G20H08-180300
108	Cavity heat insulation plate	UGP-G20A01-070800
109	Thermostat probe retaining clip	UGP-G20A01-031100
	Orifice LP Kit	UGP-G20A01
	Orifice NG Kit	UGP-G20A01



**APPLIANCE INFORMATION**  
(manual copy - keep with your records)

To make care and servicing of your range easy and efficient, please record the following information for future reference:

Model:  
\_\_\_\_\_

Serial Number:  
\_\_\_\_\_

Purchased From:  
\_\_\_\_\_

Date Purchased:  
\_\_\_\_\_

Installed By:  
\_\_\_\_\_

detach along dotted line

detach along dotted line

detach along dotted line

**APPLIANCE INFORMATION**  
(remote copy - keep with your appliance)

To make care and servicing of your range easy and efficient, please record the following information for future reference:

Model:  
\_\_\_\_\_

Serial Number:  
\_\_\_\_\_

Purchased From:  
\_\_\_\_\_

Date Purchased:  
\_\_\_\_\_

Installed By:  
\_\_\_\_\_

detach along dotted line

# PRESTIGE GAS RANGE 20" (50.8 cm) CONVECTION GAS RANGE 1 YEAR LIMITED WARRANTY



Unique Appliances Ltd. (hereafter "Unique") warrants that this UNIQUE gas range is free from manufacturer's defects in material and workmanship under normal usage and service under the following terms.

## Parts Warranty

This appliance has been designed for domestic household use. If properly installed, adjusted and operated under normal conditions in accordance with printed instructions, it will satisfactorily perform the functions that are generally expected of this type of appliance.

If the appliance fails to do so because of a defect in material or workmanship within **one year** from the original date of purchase: Unique will at our option, repair, exchange, or correct by other means Unique consider appropriate, any part(s) Unique finds to be defective except for the surface finish.

## Ownership

This Warranty is made only to the first purchaser ("original purchaser") who acquires this range for his/her own use and will be honored by Unique Appliances and by the Seller. Purchaser must retain their receipt as proof of purchase date.

## Warranty Conditions

This warranty does not apply to any appliance that has been subjected to alterations, misuse, abuse (including damage by foreign agents or chemicals), accident, improper installation or service, delivery damage, or other than normal household use and service. This UNIQUE appliance must be serviced regularly as outlined in the Owner's Manual. In case of damage, the owner must provide proof of purchase, Model, and Serial Number to the selling dealer or Unique Appliances. This warranty is LIMITED STRICTLY to the terms indicated herein, and no other expressed warranties or remedies thereunder shall be binding on Unique.

## Purchaser's Responsibilities

The purchaser will be responsible for the costs of any service calls requested to demonstrate or confirm the proper operation of the appliance, the installation, or to correct malfunctions in the appearance created by the operation of the appliance in a manner not prescribed by or cautioned against in the use and care instructions.

## Model and Serial Number

The appliance model number and serial number can be found on a rating plate on the range. The purchaser should always refer to the model and serial number when talking to or contacting the dealer from whom the appliance was purchased.

## EXCLUSIONS

Save as herein provided, by Unique, there are no other warranties, conditions, representations or guarantees, express or implied, made or intended by Unique or its authorized distributors and all other warranties, conditions, representations or guarantees, including any warranties, conditions, representations or guarantees under any Sale of Goods Act or like legislation or statute is hereby expressly excluded. Save as herein provided, Unique shall not be responsible for any damages to persons or property, including the unit itself, howsoever caused or any consequential damages arising from the malfunction of the unit and by the purchase of the unit, the purchaser does hereby agree to indemnify and hold harmless Unique from any claim for damages to persons or property caused by the unit

Removal or disfigurement of the rating plate will void the warranty. The purchaser will be responsible for any expenses involved in making the gas range readily accessible for servicing. The purchaser will be responsible for any extra charges where the installation is in a remote location such as un-assumed roads, islands, areas known as cottage country, more than 20 Km outside a Metropolitan area, or where a technician is not available. Freight damage is not covered by this warranty.

## GENERAL PROVISIONS

No warranty or insurance herein contained or set out shall apply when damage or repair is caused by any of the following:

- 1) Power failure.
- 2) Damage in transit or when moving the appliance.
- 3) Improper power supply such as low voltage, defective house wiring or inadequate fuses.
- 4) Accident, alteration, abuse or misuse of the appliance such as inadequate air circulation in the room or abnormal operating conditions (ie. extremely high or low room temperature).
- 5) Use for commercial or industrial purposes (ie. If the appliance is not installed in a domestic residence).
- 6) Fire, water damage, theft, war, riot, hostility, acts of God such as hurricanes, floods etc.
- 7) Service calls resulting in customer education.
- 8) Improper Installation (ie. Building-in of a free standing appliance or using an appliance outdoors that is not approved for outdoor application, including but not limited to: garages, patios, porches or anywhere that is not properly insulated or climate controlled).

Proof of purchase date will be required for warranty claims; retain bills of sale. In the event that warranty service is required, present the proof of purchase to our authorized service depot.

**Nothing within this warranty shall imply that Unique will be responsible or liable for any direct or indirect loss of foods caused by failure in operation.**

## Factory Assistance

If the purchaser is unable to locate an authorized dealer/service agent, or if the purchaser does not receive satisfaction from the dealer, they may contact Unique Appliances Customer Service directly at Toll Free 1-877-427-2266 or 905-827-6154.

## NOTES

---

---

---

---

---

---

---

---

## PRODUCT REGISTRATION

Please visit our website at <https://UniqueAppliances.com/product-registration/> to register your product.

## CONTACT US

For general information or questions related to the operation, safety or the purchase of your range, please contact our customer service department:



### Email

[info@UniqueAppliances.com](mailto:info@UniqueAppliances.com)



### Toll-free

1-877-427-2266 or 1-905-827-6154  
available during regular business hours,  
8:30 am to 4:30 pm, EST



### Website

[www.UniqueAppliances.com](http://www.UniqueAppliances.com)

Please visit our website for more quality Unique products:  
[www.UniqueAppliances.com](http://www.UniqueAppliances.com)

**Unique Appliances Ltd., 2245 Wyecroft Road #5,  
Oakville, Ontario, Canada, L6L 5L7**



©2020 Unique Appliances Ltd., 2245 Wyecroft Road #5,  
Oakville, Ontario, Canada, L6L 5L7

[www.UniqueAppliances.com](http://www.UniqueAppliances.com)