

DEU2450R/ADA



FEATURES

Fully customizable exterior, accepting custom panels for an integrated look within cabinetry or stainless steel accessory panels and handles to coordinate with other Sub-Zero, Wolf, and Cove appliances

Seamlessly integrating anywhere, undercounter refrigeration adds comfort to your master suite, creates a corner for libations in the study—the options are endless

ADA height compatible, offering additional handleless-design flexibility

Flexible storage options with one stationary and two adjustable shelves

Two on-door shelves easily accommodate a wide variety of condiments and beverages, with ample room for larger two-liter bottles

Intuitive, on-door touch control panel offers ergonomic, convenient access to settings

Cleanup is simple with nano-coated, spill-proof shelves

Clear storage drawer provides quick access to essential items

Offers precise temperature control within one degree of setpoint, preserving dairy, produce, craft beer, and other perishables at their optimal temperature

Soft-on LED lighting fully illuminates the interior when the door is open

Wi-Fi enabled features allow for remote temperature control, provide important door-ajar notifications, and assist with remote service diagnostics—all from your mobile device

ACCESSORIES

Custom Panel Lock Kit

Dual Install Kit - Handle-to-Handle

Pro Handle

Stainless Steel Dual Kickplate - 48"

Stainless Steel Solid Door Panel - Pro Handle, Left Hinge

Stainless Steel Solid Door Panel - Pro Handle, Right Hinge

Stainless Steel Solid Door Panel - Tubular Handle, Left Hinge

Stainless Steel Solid Door Panel - Tubular Handle, Right Hinge

Tubular Handle

Accessories are available through an authorized dealer. For local dealer information, visit subzero-wolf.com/locator.



HANDLE ACCESSORIES

PRO



TUBULAR



PRODUCT DETAILS

REFRIGERATOR

- One stationary and two adjustable shelves
- Two on-door shelves
- Clear storage drawer
- LED lighting

PRODUCT SPECIFICATIONS

Model	DEU2450R/ADA
Dimensions	24"W x 32 1/2"H x 23 1/8"D
Door Clearance	26 1/2"
Weight	132 lbs
Refrigerator Capacity	5.0 cu. ft.
Electrical Supply	115 VAC, 60 Hz
Electrical Service	15 amp dedicated circuit
Receptacle	3-prong grounding-type

ELECTRICAL

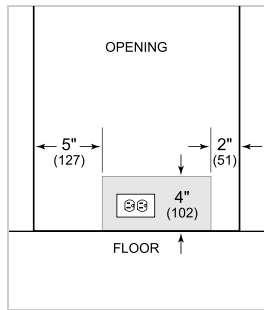

NOTE: Dimensions in parenthesis are in millimeters unless otherwise specified

INTERIOR VIEW

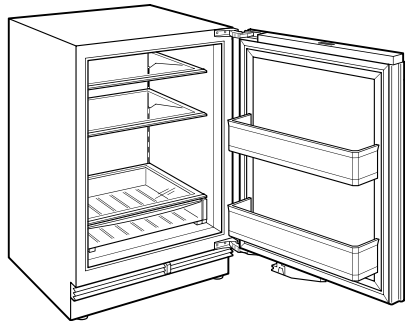

This illustration is intended for interior reference only and may not represent the exterior of the model being specified.

DIMENSIONS

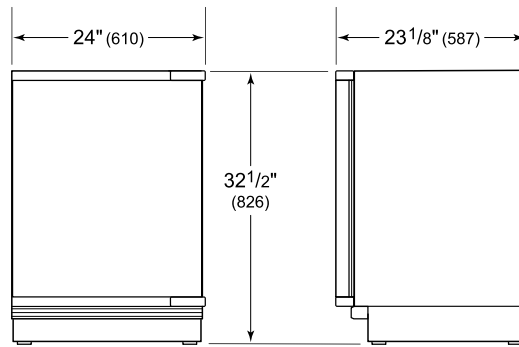

HEIGHT DIMENSIONS ± 1/2" (13)

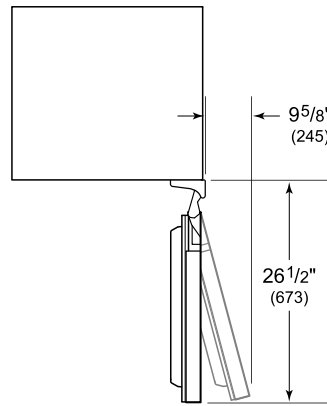

STANDARD INSTALLATION

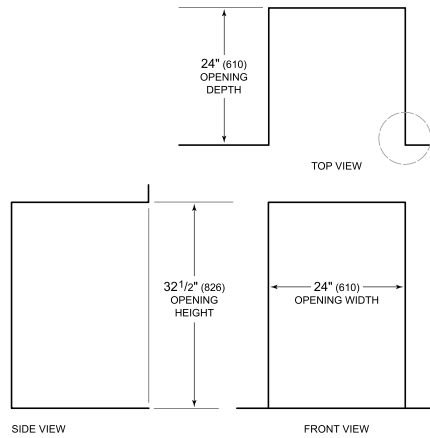

NOTE: 3/2" (89) finished returns will be visible and should be finished to match cabinetry.

