

DW80CG5420SR

SAMSUNG

Stainless Steel Dishwasher with StormWash™



Signature Features

StormWash™

Circle spray jet blasts water from two washing arms covering more angles for more intensive washing performance.

AutoRelease™ Door

Door opens automatically at end of cycle to provide better and faster drying.

SmartThings Wi-Fi Connectivity

Optimize how you use the dishwasher to suit your lifestyle. The SmartThings App* lets you remotely monitor and control it on a smartphone and download specialist programs.

Available Colour



Stainless Steel



AutoRelease™ Door



StormWash™

Features

- StormWash™ Heavy Duty Wash System
- AutoRelease™ Door
- Wi-Fi Embedded
- Digital Leakage Sensor
- Delay Start
- FlexLoad™ Racking System
- Touch Control
- Half-Load Cycle
- One-Touch Adjustable Racking System
- Quiet Operation – 48 dBA
- Full Stainless Steel Interior
- Hidden Heating Element
- 14 Place Settings
- Hard Food Disposer Cleaning System
- 3 Spray Wash Arms - Upper, Middle, Lower
- 7 Wash Cycles and 7 Wash Options
- 2 Silverware Baskets

Convenience

- Control Lock
- Rinse Refill Indicator
- AI Energy Mode Indicator
- SmartThings Indicator
- Self-Cleaning Cycle
- Six Sensors - Digital Water Leakage, Overflow, Sanitize, Turbidity, Water Fill, Rinse Refill

Rating



- ENERGY STAR® 7.0 - Rated 239 kWh/yr

** Requires a wireless network, a Samsung account and the Samsung SmartThings App. The Samsung SmartThings App supports Android OS 8.0 (Oreo) or later, which is optimized for Samsung smartphones. This App also supports iOS 13 or later for iPhone models. The SmartThings App is available in the App Store and Play Store. Available in certain languages, including English, French, German, Italian and Spanish.

DW80CG5420SR

SAMSUNG

Stainless Steel Dishwasher with StormWash™

Installation Specifications

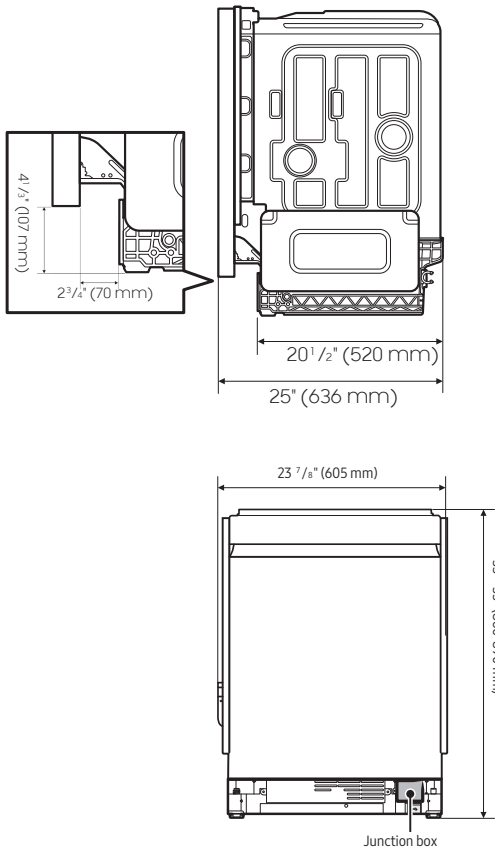

Dimensions

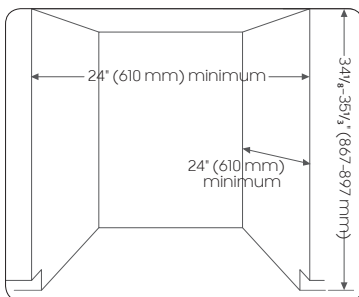

NOTE

This dishwasher is designed to be enclosed on the top and on both sides by a standard residential kitchen cabinet unit. The installation cabinet must be clean and free of any obstructions. The cabinet must be at least 24 inches wide, 24 inches deep, and 34 1/8 inches high. For the front door of the dishwasher to be flush with the leading edge of the counter top, the counter top must be at least 25 inches deep.

Features

- **7 Wash Cycles:**
Auto, Heavy, Normal, Express 60, Delicate, Pre-Blast, Download Cycle
- **7 Wash Options:**
StormWash™, Lower Rack Half Load, Sanitize, Hi-Temp Wash, Delay Start, Control Lock
- Smart Control
- Hidden Heat Element
- Stainless Steel Interior Tub

Convenience

- Control Lock
- Digital Water Leakage Sensor: Detects water leaks before they happen and shuts off the dishwasher to prevent water damage
- Nylon Racking
- Upper Rack: Basket handle, Adjustable Height
- 2 Silverware Baskets

Warranty

One (1) Year All Parts and Labour
Five (5) years, Printed Circuit Board, Racking and Stainless Door Liner & Tub for Leakage (Parts Only)

Product Dimensions & Weight (WxHxD)

Dimensions (height is adjustable):

23 7/8" x 33 7/8" x 25"

Weight: 84 lb (38 kg)

Shipping Dimensions & Weight (WxHxD)

Dimensions: 26" x 34 7/8" x 29 3/4"

Weight: 86 lb (39 kg)

Colour

Stainless Steel

Model

DW80CG5420SR

UPC

887276763842