

INSERT-30

30" Built-In Insert Rangehood



Signature Features

Three Speed Adjustments

Three different speeds to tackle cooking odors and eliminate smoke from cooking as needed.

LED Lighting Strip

LED lights illuminate the cooktop and are brighter more energy efficient.

Electronic Push Buttons

Add a sophisticated look with this up-front, easy-to-use display.

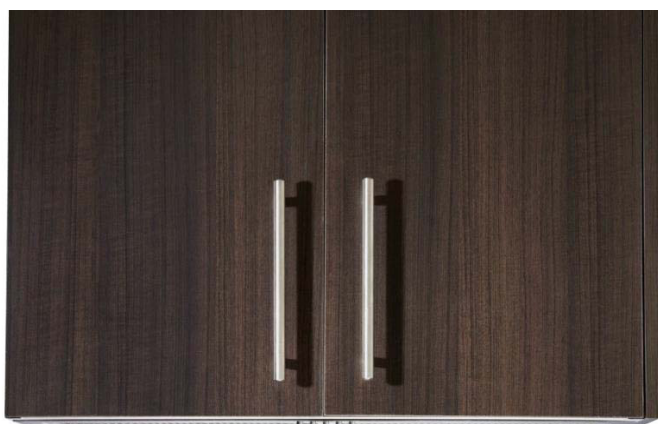

Features

- European Under Cabinet Style
- Stainless Steel
- 3 Speed adjustment
- 2 x Perforated Filter
- Electronic Push Buttons
- LED Strip Lamp
- Quiet (7 Sones / 56 dB)
- 300 CFM Motor

Ducting Outlet

- 6" (150mm)

Technical Specifications

Product Dimensions (W//D)

- 30" / 11⁷/₁₆"
- 762mm / 290mm

Cut Out Dimensions (W//D)

- 28³/₄" / 10¹¹/₁₆"
- 730mm / 272mm

Weight

- Net Weight: 8.2kg (18 lbs.)
- Gross Weight: 10kg (22 lbs.)

Electrical Requirements

- 115 V / 60 Hz / 15 Amp
- Rated Input Power: 97 Watts
- Rated Output Power: 95 Watts
- Supplied with a Canadian Cord and Plug

INSERT-30

Specifications



Product Dimensions (W//D)

- 30" / 117¹/₁₆"
- 762mm / 290mm

Cut Out Dimensions (W//D)

- 28³/₄" / 10¹¹/₁₆"
- 730mm / 272mm

Electrical Requirements

- 115 V / 60 Hz / 15 Amp
- Rated Input Power: 97 Watts
- Rated Output Power: 95 Watts
- Supplied with a Canadian Cord and Plug

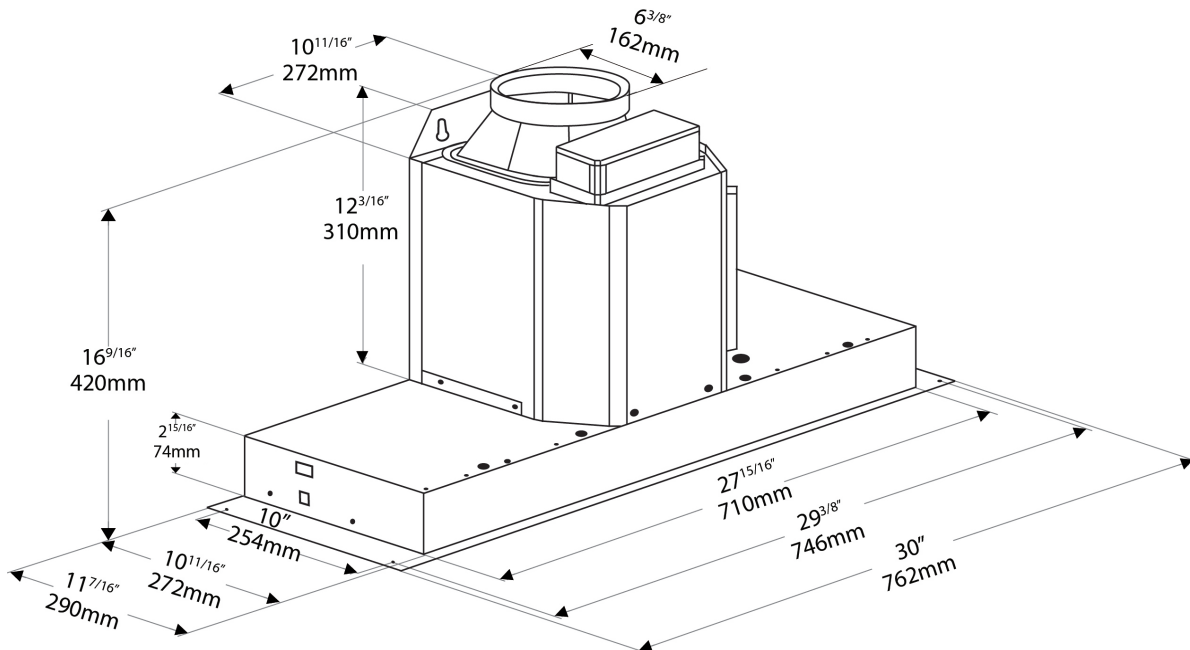
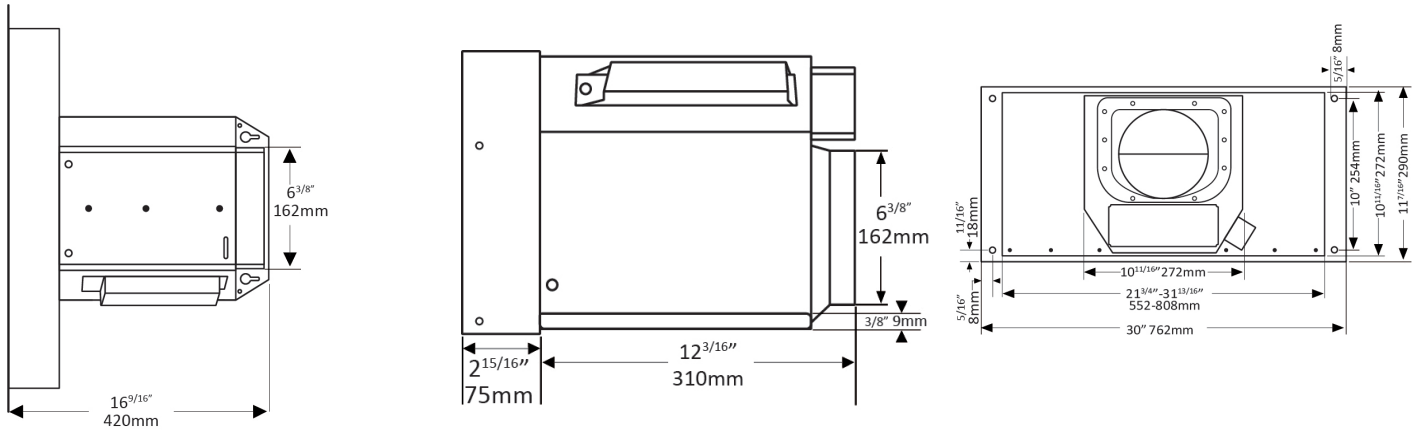

Other Product Downloads Available at porterandcharles.ca

- [Download User Manual](#)



WARRANTY INFORMATION

Porter & Charles Appliances are designed and manufactured to the highest standards. Each appliance is covered by a comprehensive 2-year parts and labour warranty. Refer to product warranty policy for complete terms and conditions.

FOR PARTS & SERVICE

Euro-Parts & Service
39822 Belgrave Road, Belgrave, ON. N0G 1E0 1 866 722 2262
www.euro-parts.ca • parts@euro-parts.ca • service@euro-parts.ca

Porter & Charles appliances are imported and distributed in North America by Euro-Line Appliances Inc. For more information, please visit one of our showrooms or www.ela.ca / www.elawest.ca

EURO-LINE APPLIANCES INC.

871 Cranberry Court, Oakville, ON
L6L 6J7 Canada
905 829 3980
1 800 421 6332
info@ela.ca

EURO-LINE APPLIANCES INC.

101-1014 Homer Street, Vancouver, BC
V6B 2W9, Canada
604 235 3980
1 855 ELA WEST (352 9378)
info@elawest.ca