

FEC76B3

30" Freestanding Stainless Steel Electric Range



Signature Features

Electric Zones

Four zones and one expandable cooking zones, allowing you to do more on your range.

True Fan Convection Cooking

Cook foods faster with the addition of a third element plus a fan that distributes hot air evenly over, under, and around food, ensuring even baking and roasting results every time.

Heavy Duty Metal Knobs

Heavy duty metal knobs deliver a premium finish and fit, with the durability that you expect.

General Properties

- Electric Slide-In Range
- Anti-Fingerprint Stainless Steel
- Adjustable Leg Height
- Flush with Cabinets



Telescopic Racks



Heavy Duty Control Knobs

Features

- 4 Elements, 2 Extendable
- 2 x 145mm Element**
- 1,200 W
- 1 x Double Ring Element**
- 120mm – 750 W
- 210mm - 2,200 W
- 1 x Expandable Element**
- 190mm – 1,400 W
- 285mm – 2,200 W
- Residual Heat Indicator

Oven Features

- 105 / 3.8 cu. ft. Oven Capacity
- 9 Cooking Functions
- True Fan Convection Cooking
- Double Glazed Door
- Diamond Glazed Interior
- Interior Halogen Lamp
- Fully-Programmable Clock/Timer with Delay Start and Finish
- Full extension telescopic rails
- Warming Drawer

Oven Functions

- Defrost
- True Fan Convection
- Fan Assist Cooking / Fan Assist Grill
- High Bake Cooking
- Full / Half Grill
- Pizza Mode
- Conventional Oven Cooking

Technical Specifications

Product Dimensions (W/H/D)

- 30" / 36¹/₄" / 25³/₁₆"
- 762mm / 920mm / 640mm

Cut Out Dimensions (W/H/D)

- 30¹/₁₆" / 35⁷/₁₆" / 24¹/₂"
- 764mm / 900mm / 622mm

Electrical Requirements

- 208/240 volt, 60Hz, 40 amp
- Supplied with range cord and plug

Accessories

- Grill / Roasting Pan
- Reversible Grill Insert
- Full-Extension Telescopic Rails
- 2 Chrome Oven Racks

FEC76B3

Specifications



Product Dimensions (W/H/D)

- 30" / 36¹/₄" / 25³/₁₆"
- 762mm / 920mm / 640mm

Cut Out Dimensions (W/H/D)

- 30¹/₁₆" / 35⁷/₈" / 24¹/₂"
- 764mm / 900mm / 622mm

Electrical Requirements

- 208/240 V / 60 Hz / 40 Amp
- Supplied with a 5' long electrical cable and must be hardwired.

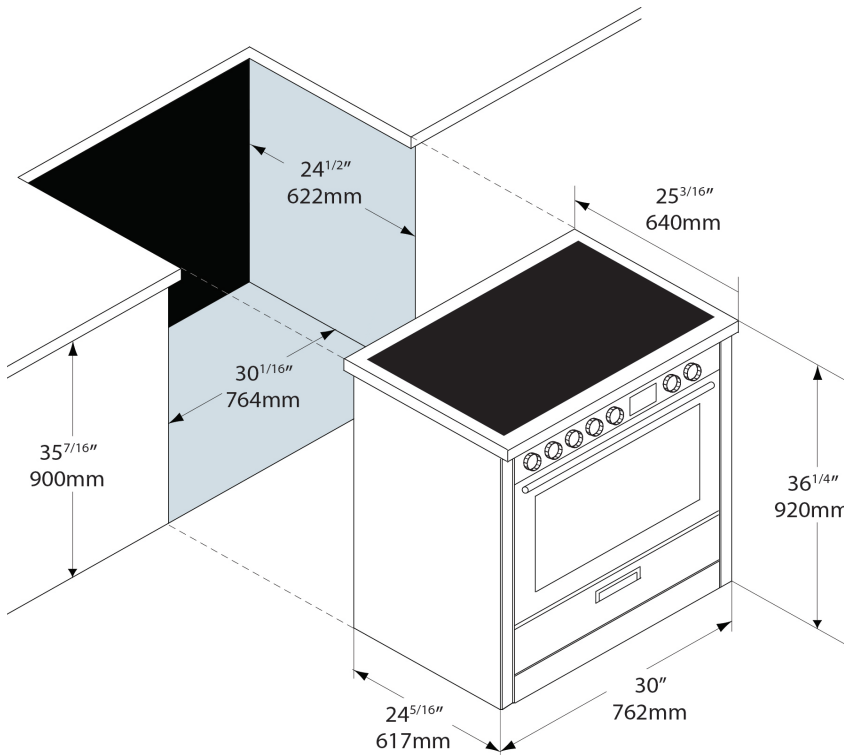

Rear View

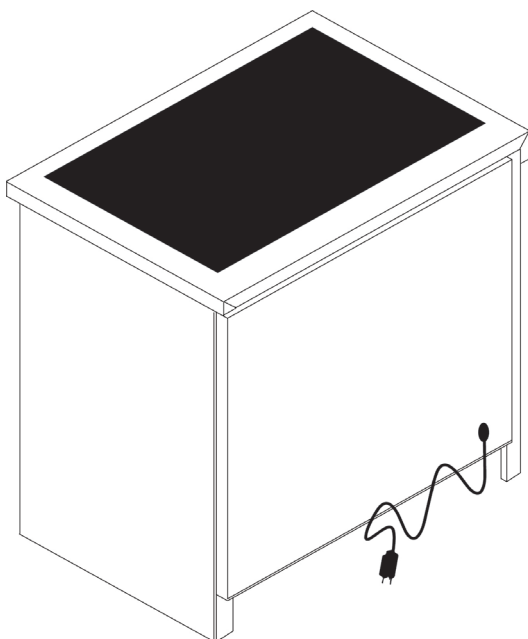

FEC76B3

Specifications



Recommended Cabinet Minimum Clearance

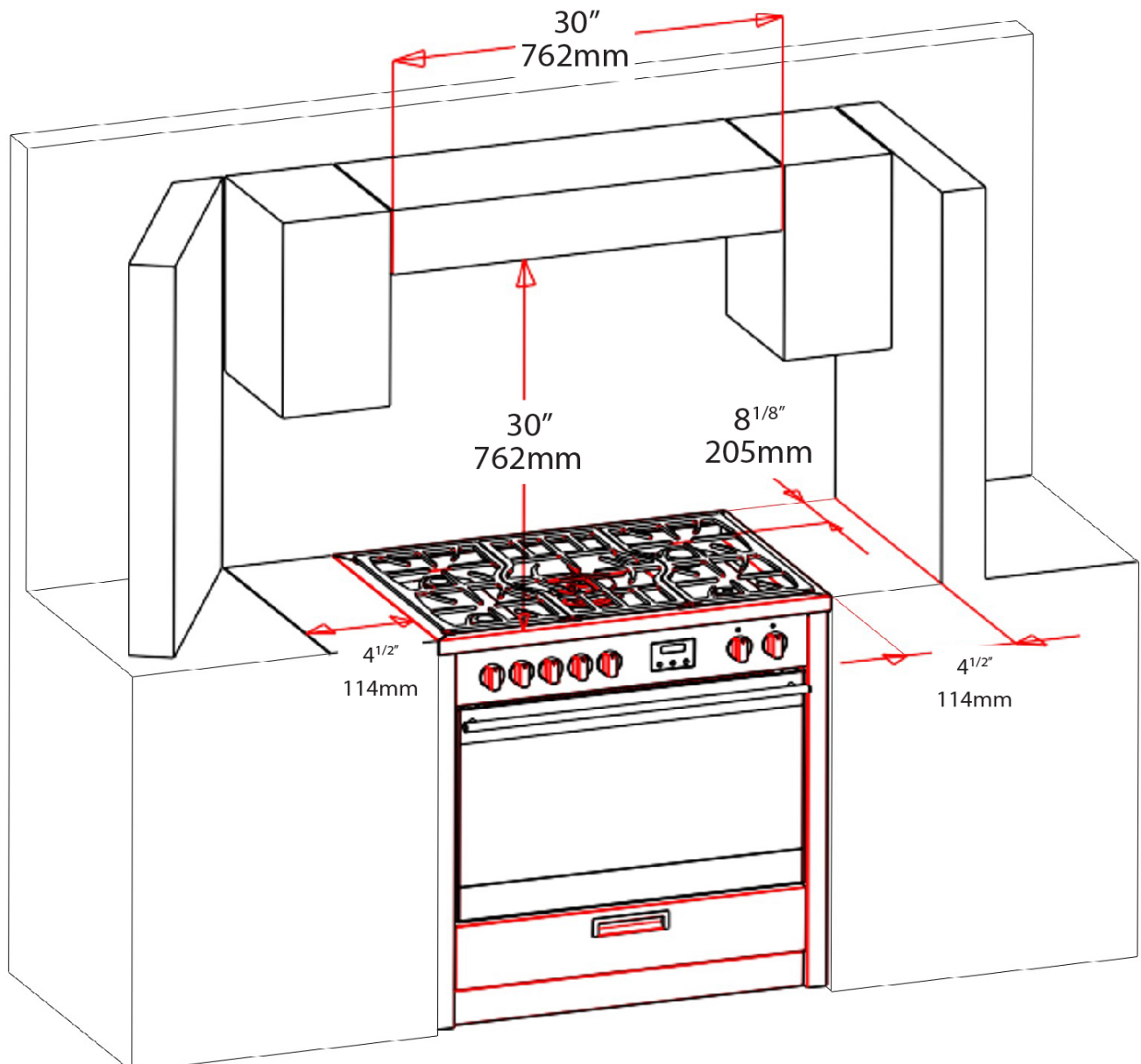

Other Product Downloads Available at porterandcharles.ca

- [Download User Manual](#)



WARRANTY INFORMATION

Porter & Charles Appliances are designed and manufactured to the highest standards. Each appliance is covered by a comprehensive 2-year parts and labour warranty. Refer to product warranty policy for complete terms and conditions.

FOR PARTS & SERVICE

Euro-Parts & Service
39822 Belgrave Road, Belgrave, ON. N0G 1E0 1 866 722 2262
www.euro-parts.ca • parts@euro-parts.ca • service@euro-parts.ca

Porter & Charles appliances are imported and distributed in North America by Euro-Line Appliances Inc. For more information, please visit one of our showrooms or www.ela.ca / www.elawest.ca

EURO-LINE APPLIANCES INC.

871 Cranberry Court, Oakville, ON
L6L 6J7 Canada
905 829 3980
1 800 421 6332
info@ela.ca

EURO-LINE APPLIANCES INC.

101-1014 Homer Street, Vancouver, BC
V6B 2W9, Canada
604 235 3980
1 855 ELA WEST (352 9378)
info@elawest.ca