

# CI90V

## 36" Built-In Induction Cooktop

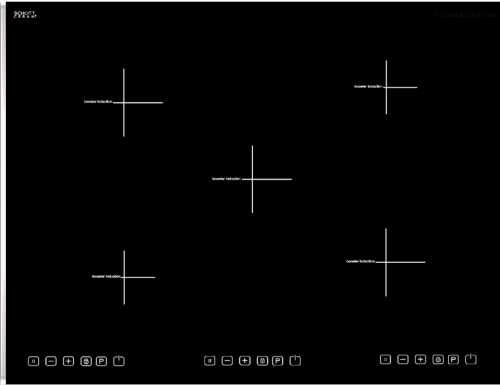

### Signature Features

#### Black Ceramic Glass Surface

Smooth surface offers a modern style in an easy-to-clean design.

#### Induction Zones

Faster and safer, magnetic waves induce heat directly to the pan for quick boiling and intense sears, leaving less heat on the surface.

#### Digital Touch Control

Accurately control your heating with user-friendly touch controls on a surface that is easy to clean.

### General Properties

- Induction Cooktop
- Black Ceramic Glass Surface
- Stainless Steel Trim
- Beveled Edges

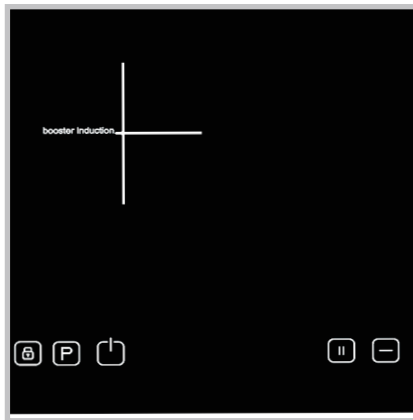

Power Boost

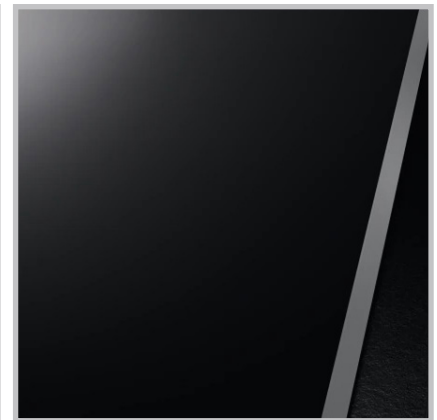

Stainless Steel Trim

### Features

- 5 induction zones
- 9 power levels with Power Boost
- Touch control panel
- Automatic switch off
- Smart Pause
- Count-down timer
- Residual heat indicator
- Child safety lock
- Shallow depth allows for easy install over drawers or an oven

### Cooktop Performance

- 2 x 16cm Single Zones**
  - 1,400 Watts
  - 1,800 Watt - Power Boost
- 2 x 20cm Single Zones**
  - 1,800 Watts
  - 2,500 Watt - Power Boost
- 1 x 25cm Single Zones**
  - 2,800 Watts
  - 3,500 Watt - Power Boost

### Technical Specifications

#### Cooktop Dimensions (W/H/D)

- 35<sup>1</sup>/<sub>4</sub>" / 2" / 20<sup>1</sup>/<sub>2</sub>"
- 895mm / 51mm / 521mm

#### Cut Out Dimensions (W/H/D)

- 33<sup>1</sup>/<sub>4</sub>" / min. 3<sup>1</sup>/<sub>8</sub>" / 19<sup>3</sup>/<sub>16</sub>"
- 857mm / min. 80mm / 487mm

#### Electrical Requirements

- 208/240 volt, 60Hz, 40 amp, 10800W
- Supplied with a 5ft long electrical cable and must be hard wired

# CI90V

## Specifications



### Product Dimensions (W/H/D)

- Width: 35<sup>1</sup>/<sub>4</sub>" (895mm)
- Height: 2" (51mm)
- Depth: 20<sup>1</sup>/<sub>2</sub>" (521mm)

### Cut Out Dimensions (W/H/D)

- Width: 33<sup>3</sup>/<sub>4</sub>" (857mm)
- Height: min. 3<sup>7</sup>/<sub>8</sub>" (80mm)
- Depth: 19<sup>3</sup>/<sub>16</sub>" (487mm)

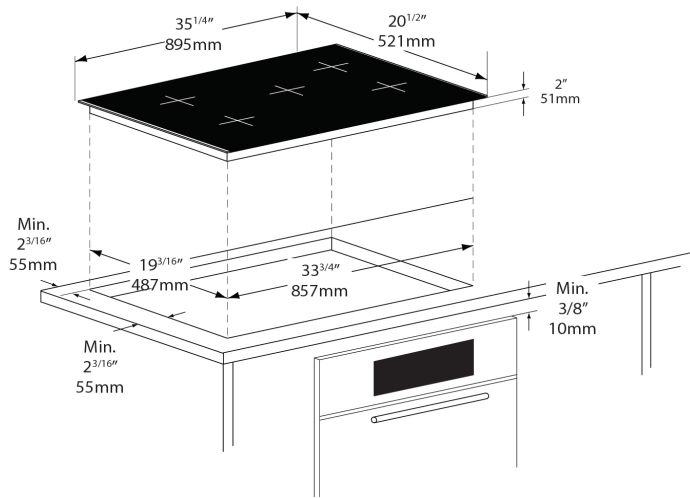

### Side View

- There must be a minimum of 20mm (13/16") of space between the bottom of the cooktop and the oven to allow air to flow.
- There must be a minimum of 5mm (3/16") of space between the countertop and built-in oven/drawer door panel.
- If there is insufficient airflow, the appliances life span will be shortened.

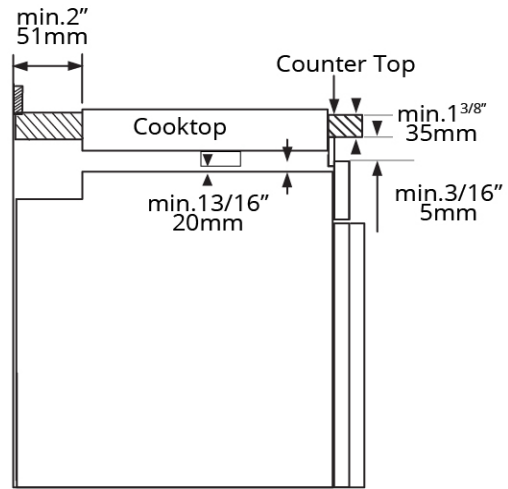

### Underneath View

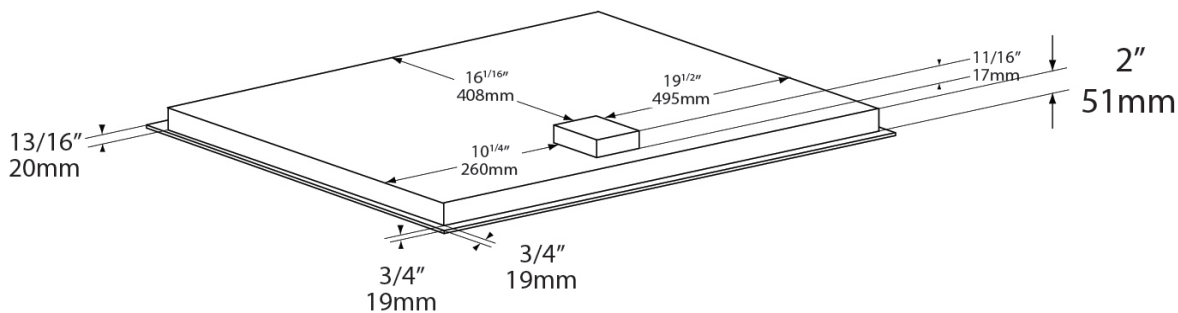

# CI90V

## Specifications



### Recommended Minimum Clearance

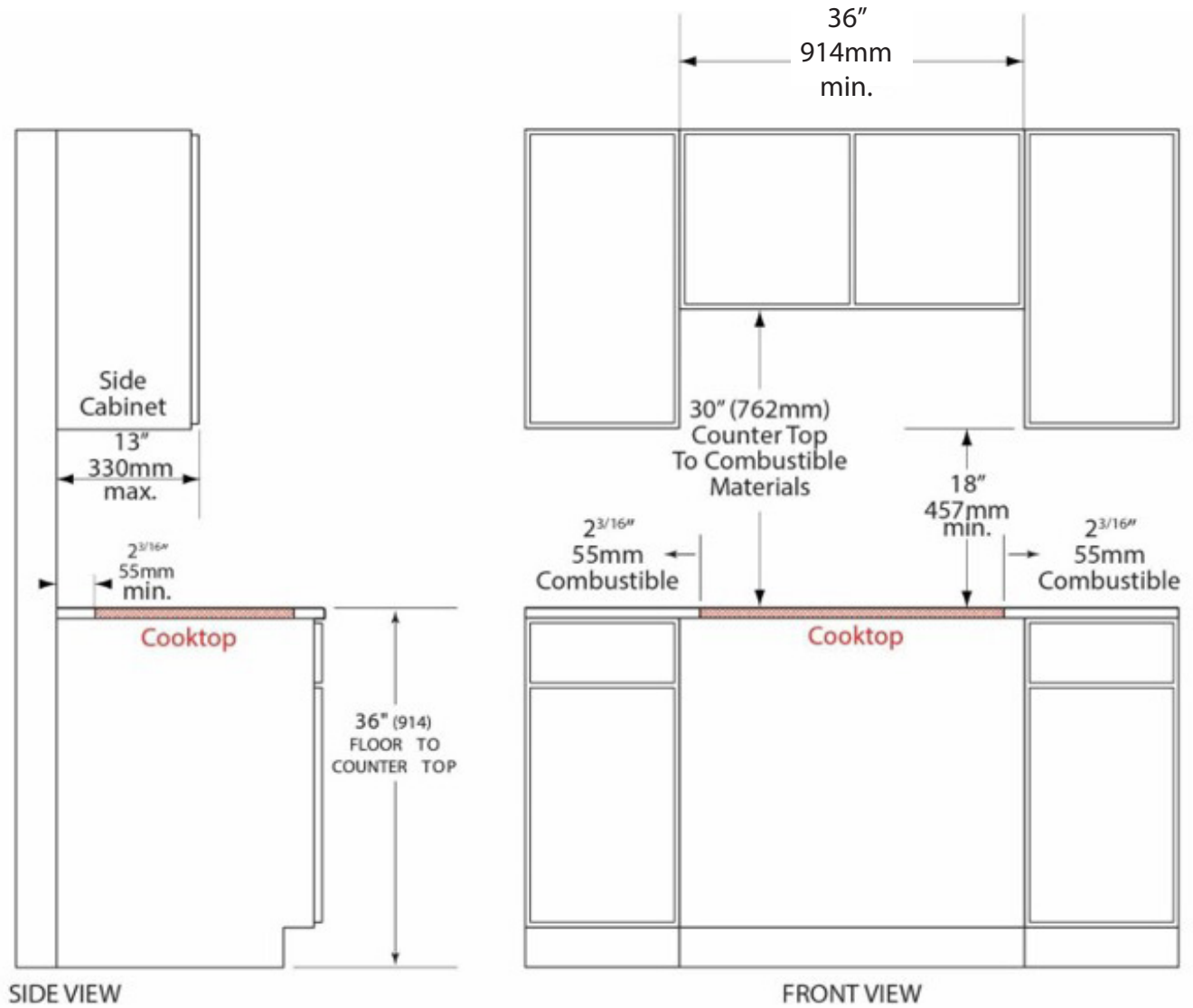

Other Product Downloads Available at [porterandcharles.ca](http://porterandcharles.ca)

- [Download User Manual](#)



#### WARRANTY INFORMATION

Porter & Charles Appliances are designed and manufactured to the highest standards. Each appliance is covered by a comprehensive 2-year parts and labour warranty. Refer to product warranty policy for complete terms and conditions.

#### FOR PARTS & SERVICE

Euro-Parts & Service  
39822 Belgrave Road, Belgrave, ON. N0G 1E0 1 866 722 2262  
[www.euro-parts.ca](http://www.euro-parts.ca) • [parts@euro-parts.ca](mailto:parts@euro-parts.ca) • [service@euro-parts.ca](mailto:service@euro-parts.ca)

Porter & Charles appliances are imported and distributed in North America by Euro-Line Appliances Inc. For more information, please visit one of our showrooms or [www.ela.ca](http://www.ela.ca) / [www.elawest.ca](http://www.elawest.ca)

#### EURO-LINE APPLIANCES INC.

871 Cranberry Court, Oakville, ON  
L6L 6J7 Canada  
905 829 3980  
1 800 421 6332  
[info@ela.ca](mailto:info@ela.ca)

#### EURO-LINE APPLIANCES INC.

101-1014 Homer Street, Vancouver, BC  
V6B 2W9, Canada  
604 235 3980  
1 855 ELA WEST (352 9378)  
[info@elawest.ca](mailto:info@elawest.ca)