

CG60WOK-F

24" Stainless Steel Built-In Gas Cooktop



Signature Features

Stainless-Steel Ergonomic Controls

Perfect results are within reach with stainless-steel up-front controls for a premium look and feel.

Continuous Cast Iron Support Grates

Let's you slide pots easily from one burner to another.

Wok Ring

Easily accommodate a wok pan on the Wok ring and also provides other large pans with extra stability, ensuring even distribution while you cook.

General Properties

- Gas Cooktop
- UltraFlush stainless steel design
- LPG Conversion Kit Included



Double Wok



Electronic Ignition

Features

- 4 high quality gas burners
- Continuous cast iron support grates
- Cast iron wok support ring
- Ergonomically placed control knobs
- Electronic ignition
- Flame failure safety system
- Shallow depth allows for easy install over drawers or an oven

Burner Performance

- 1 x Double Ring Wok Burner**
 - 13,600 BTU
- 2 x Sem-Rapid Burner**
 - 8,000 BTU
- 1 x Simmer Burner**
 - 5,000 BTU down to 600 BTU

Technical Specifications

Cooktop Dimensions (W/H/D)

- 23^{3/16"} / 2^{3/8"} / 19^{15/16"}
- 589mm / 60mm / 507mm

Cut Out Dimensions (W/H/D)

- 22^{13/16"} / min. 2^{1/2"} / 18^{7/8"}
- 580mm / min. 63mm / 480mm

Electrical Requirements

- 115 volt, 60Hz, 15 amp
- Supplied with 5ft electrical cord and plug

CG60WOK-F

Specifications



Product Dimensions (W/H/D)

- Width: 23^{3/16}" (589mm)
- Height: 2^{3/8}" (60mm)
- Depth: 19^{15/16}" (507mm)

Cut Out Dimensions (W/H/D)

- Width: 22^{13/16}" (580mm)
- Height: min. 2^{1/2}" (63mm)
- Depth: 18^{7/8}" (480mm)

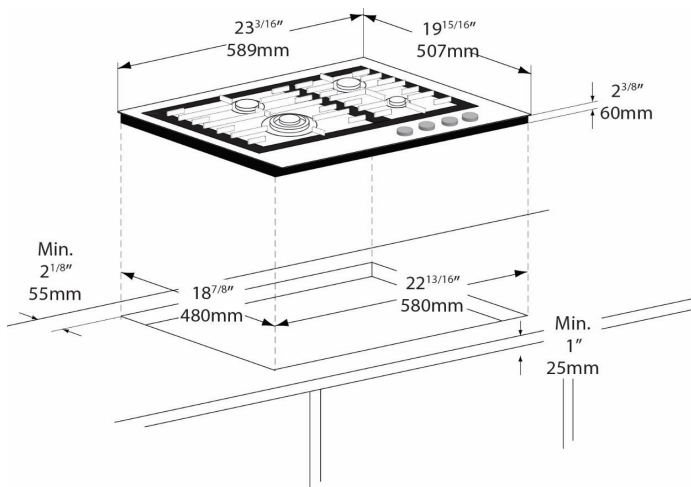

Side View

- There must be a minimum of 20mm (13/16") of space left between the bottom of the cooktop and the oven to allow air to flow.
- There must be a minimum of 5mm (3/16") of space left between the counter top and the door panel of a built-in oven / drawer.
- If insufficient air flow is provided, the life of the appliance will be shortened.

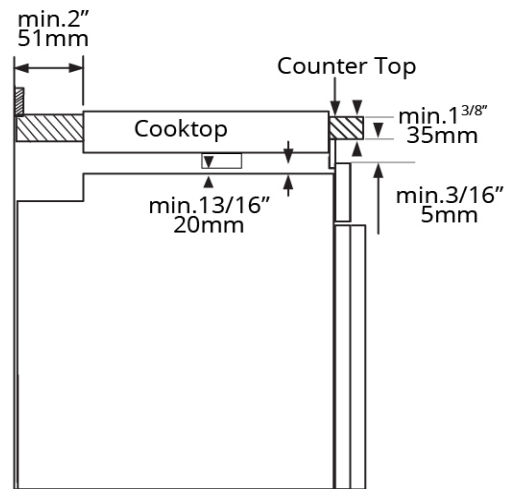

Gas Hookup Fittings

- P&C gas cooktops requires a 1/2" gas inlet and outlet fittings.

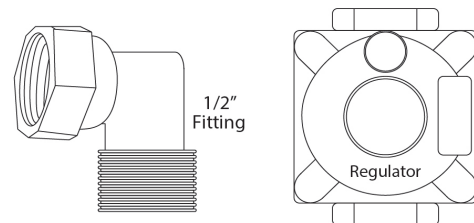

Underneath View

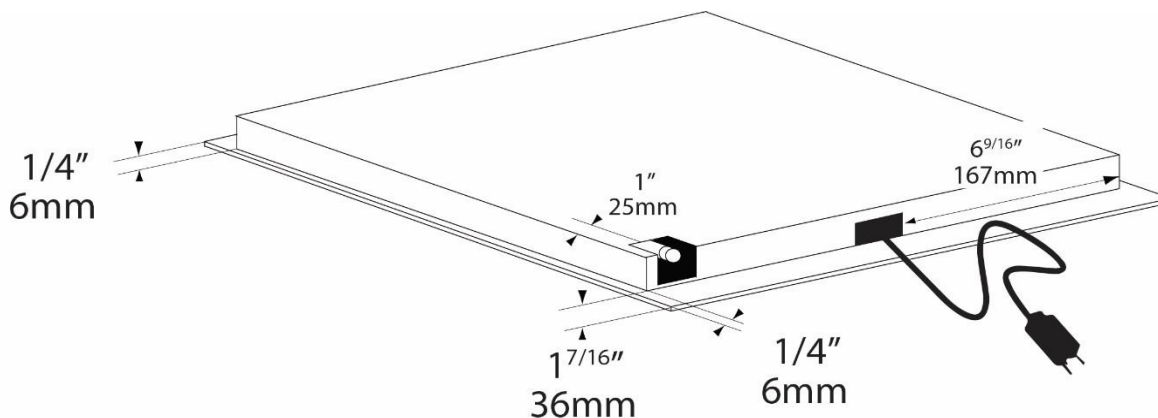

CG60WOK-F

Specifications



Recommended Minimum Clearance

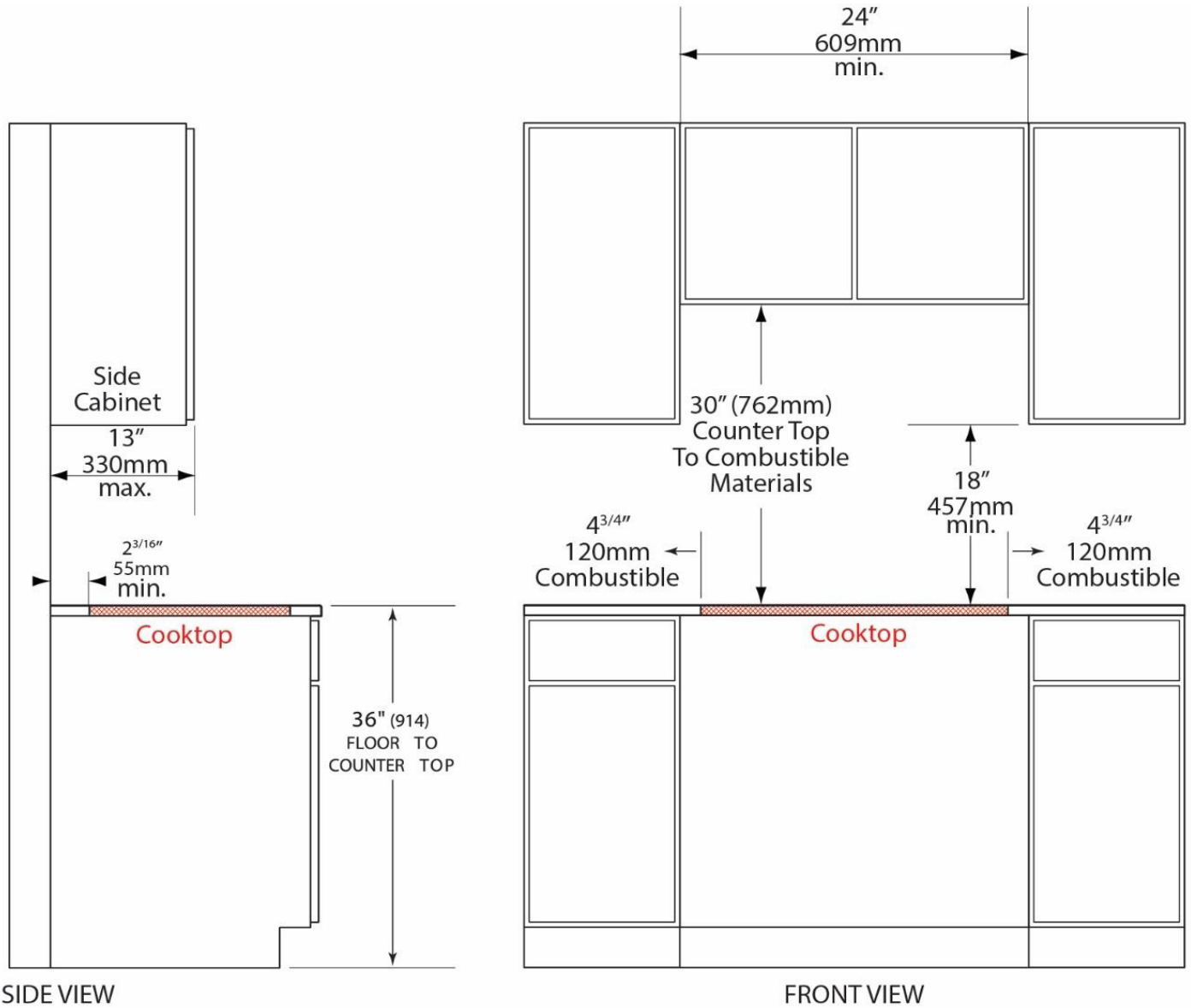

Other Product Downloads Available at porterandcharles.ca

- [Download User Manual](#)



WARRANTY INFORMATION

Porter & Charles Appliances are designed and manufactured to the highest standards. Each appliance is covered by a comprehensive 2-year parts and labour warranty. Refer to product warranty policy for complete terms and conditions.

FOR PARTS & SERVICE

Euro-Parts & Service
39822 Belgrave Road, Belgrave, ON. N0G 1E0 1 866 722 2262
www.euro-parts.ca • parts@euro-parts.ca • service@euro-parts.ca

Porter & Charles appliances are imported and distributed in North America by Euro-Line Appliances Inc. For more information, please visit one of our showrooms or www.ela.ca / www.elawest.ca

EURO-LINE APPLIANCES INC.

871 Cranberry Court, Oakville, ON
L6L 6J7 Canada
905 829 3980
1 800 421 6332
info@ela.ca

EURO-LINE APPLIANCES INC.

101-1014 Homer Street, Vancouver, BC
V6B 2W9, Canada
604 235 3980
1 855 ELA WEST (352 9378)
info@elawest.ca