

ContourLine
60cm Steam Oven

DG 6500



ContourLine 60cm Steam Oven DG 6500



DG 6500

Features:

- SensorTronic controls: 5-line TFT display with laterally positioned sensor controls that clearly present menu content
- MultiSteam technology delivers powerful external steam generation and optimum steam distribution via 8 inlet ports
- MultiSteam logo illuminates on the back cavity for a “wow” effect
- 1.34 cu.ft. (38L) cavity — 26% more capacity on 4 shelf levels
- Steam reduction creates a safe environment when opening the door and removing your food
- Easy clean-up through stainless steel cavity
- MasterChef menu offers over 150 food types to cook to perfection
- 1/2 gallon dishwasher-safe water container
- A ClearView door and interior lighting allow you to see into the steam oven as it's cooking
- ComfortSwivel handle moves with the motion of your wrist, creating a more ergonomic feel when opening and closing the oven door

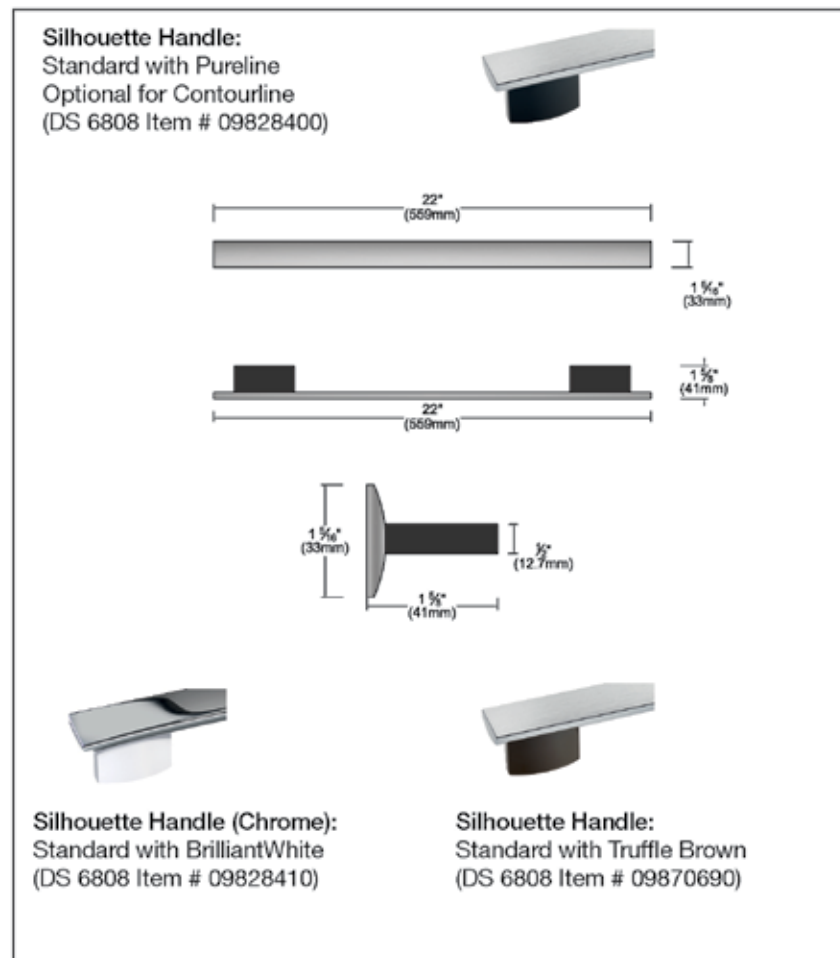
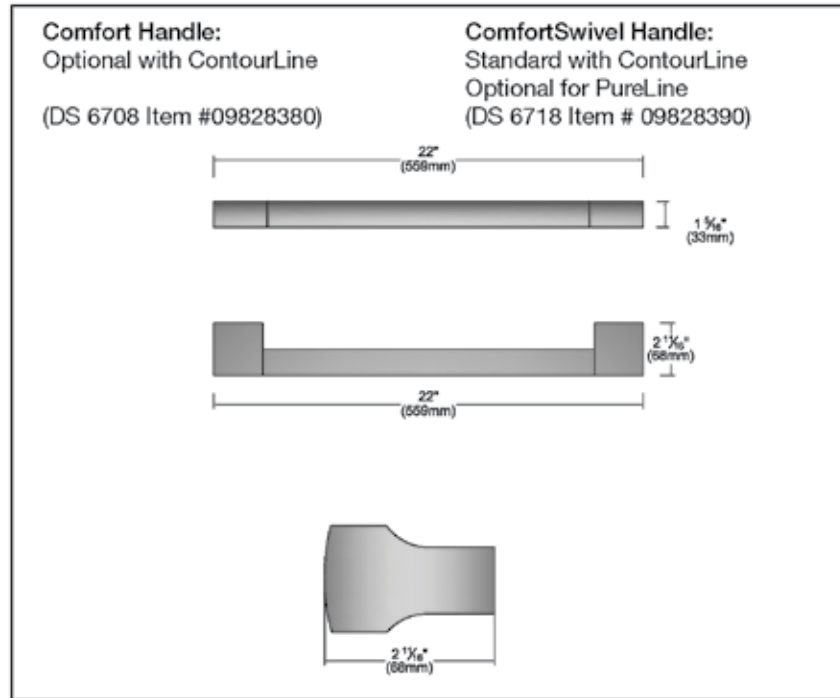

ContourLine 60cm Steam Oven DG 6500



SPECIFICATIONS	
DG 6500 — Item 23650050USA	
Overall Unit Width - Excluding Fascia Dimension	21 ³ / ₄ " (553mm)
Overall Height - Excluding Fascia Dimension	17 ⁹ / ₁₆ " (446mm)
Overall Unit Depth - Excluding Fascia Dimension	21 ⁵ / ₈ " (549mm)
Oven Door Clearance	34 ¹¹ / ₁₆ " (898mm)
Overall Oven Interior Capacity	1.3 cu.ft - 38.0 liters
Overall Fascia Dimensions	23 ⁷ / ₁₆ " (595mm) W x 18" (455.5mm) H x 7 ⁷ / ₈ " (22mm) D
Oven Interior Dimensions	13" (330mm) W x 9 ¹ / ₂ " (241mm) H x 14" (356mm) D
Built-In	
Minimum Cabinet Width	22 ¹ / ₁₆ " — 22 ³ / ₈ " (560 — 568mm)
Minimum Cabinet Depth	> 21 ⁵ / ₈ " (550mm)
Minimum Cabinet Opening Height	17 ¹¹ / ₁₆ " — 17 ¹³ / ₁₆ " (450 — 452mm)
Minimum Base Support	60 lbs
Additional Cut-outs Required	Power cord cut-out
Electrical	
Electrical Requirements	240V 60Hz 15A
Power Cord	Molded plug - NEMA 6-15A plug, 240V power cord
Cut out for power cord	Minimum 3" square
Electrical Rating	2.7kW (240V)
Total Amps	11.25A on 240V
Shipping	
Shipping Weight	65 lbs
Shipping Dimensions	26 ⁷ / ₃₂ " W x 21 ⁵ / ₈ " H x 23 ¹ / ₁₆ " L
Support	
Call	800.843.7231
20/20	©2020technologies.com

PRODUCT VIEWS

Isometric View

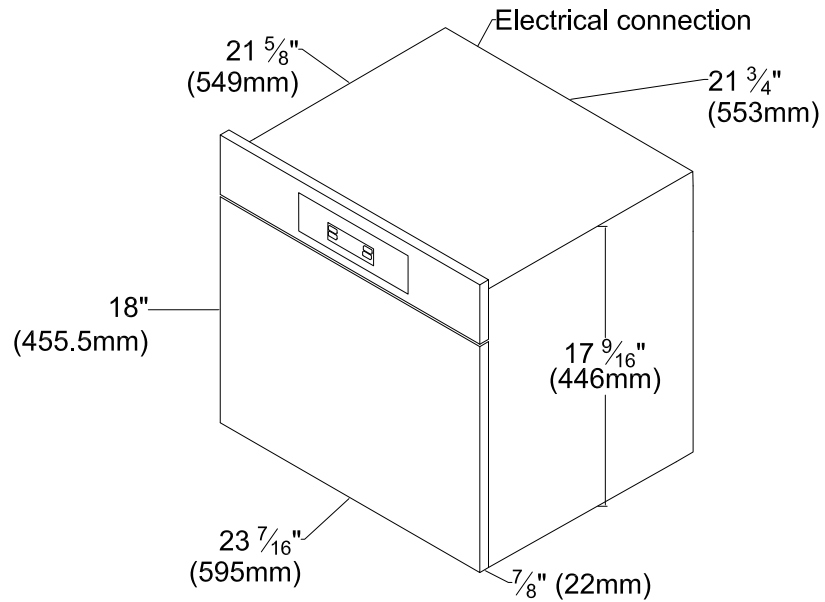

Top View

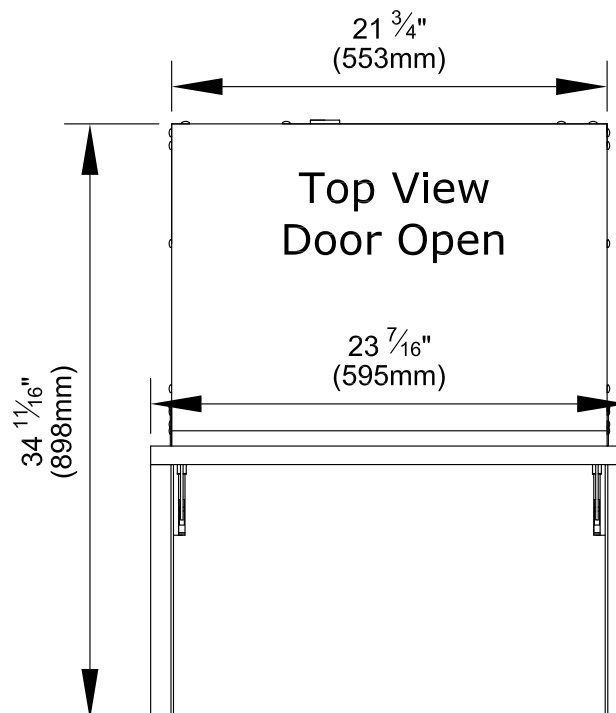

PRODUCT VIEWS

Front View

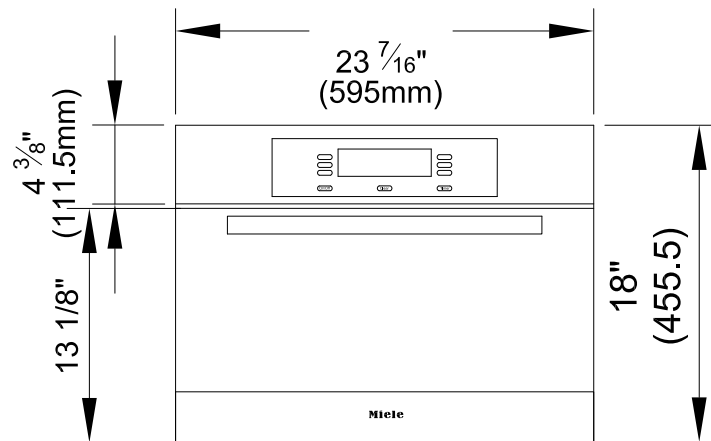

Side View

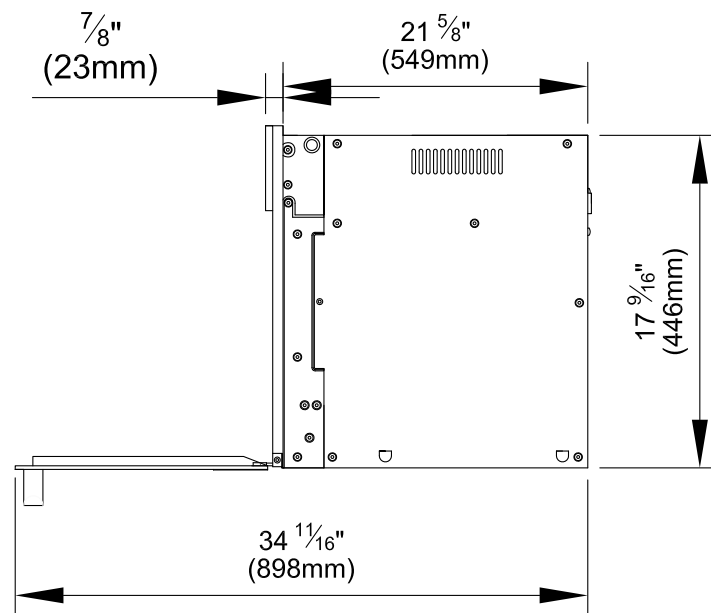

INSTALLATION SPECIFICATIONS

Installation in Tall Cabinet

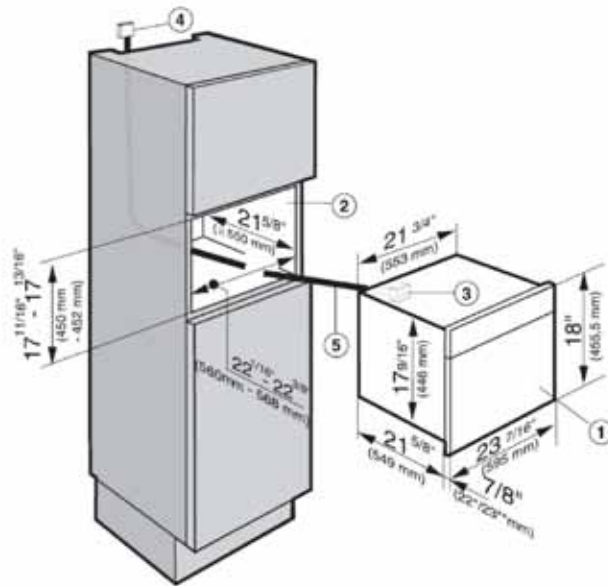

- * Appliances with glass front
- ** Appliances with metal front
- ① Built-in steam oven
- ② Installation niche
- ③ Power cord - Connection on the appliance
- ④ Recommended location of the electrical outlet
- ⑤ Power cord

Installation above 60cm Oven

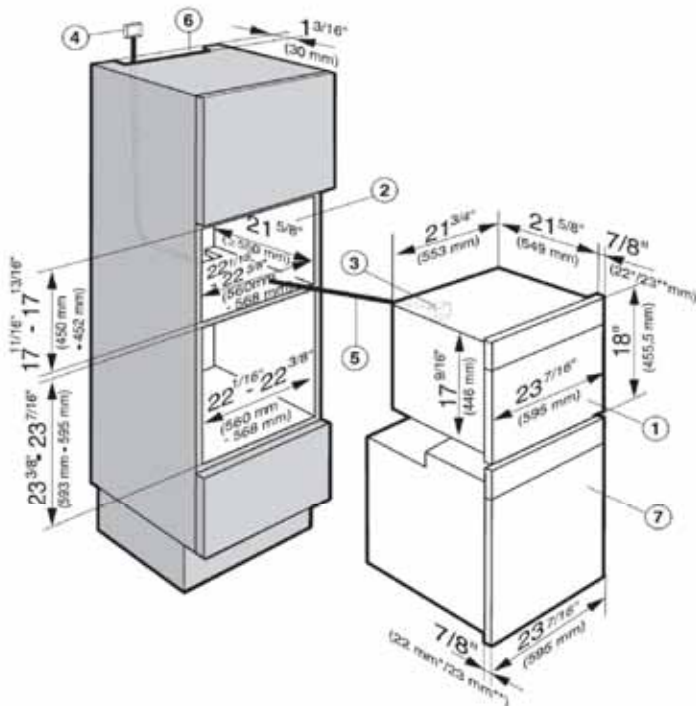

- * Appliances with glass front
- ** Appliances with metal front
- ① Built-in steam oven
- ② Installation niche
- ③ Power cord - Connection on the appliance
- ④ Recommended location of the electrical outlet
- ⑤ Power cord
- ⑥ Cut-out for ventilation when combined with a self-cleaning oven
- ⑦ Oven

ContourLine 60cm Steam Oven DG 6500



INSTALLATION SPECIFICATIONS

Installation Under Counter

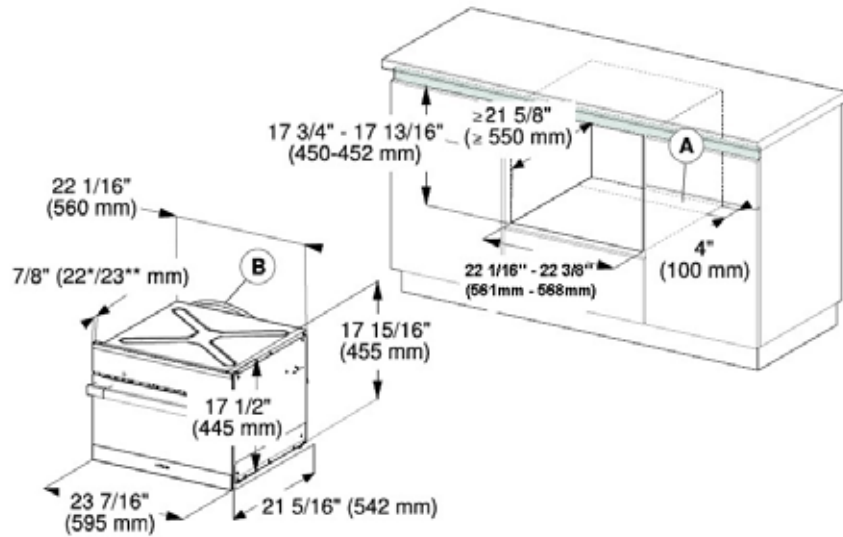

* Oven with glass front
** Oven with metal front

Door Swing and Face Detail

