

Operating and Installation Instructions

Steam Oven

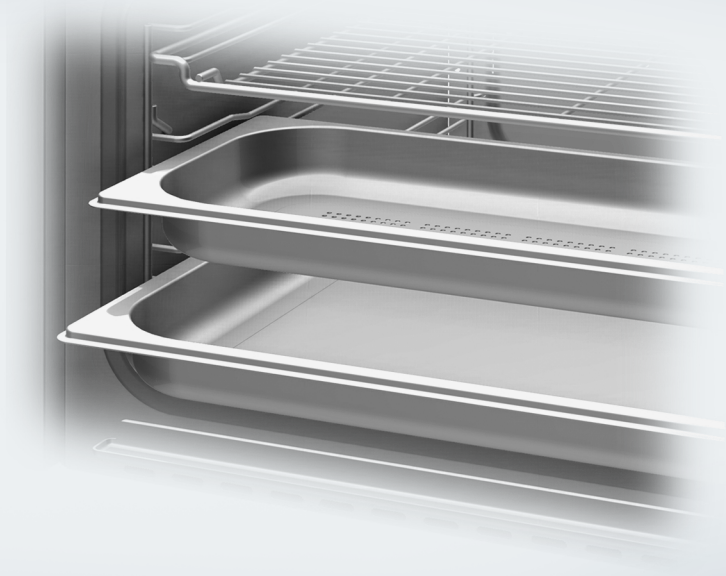



To prevent accidents and machine damage, read these instructions **before** installation or use.

Contents

IMPORTANT SAFETY INSTRUCTIONS	6
Overview	15
Steam oven front view	15
Included accessories	16
Control panel	17
Sensor buttons.....	18
Symbols	19
Description of functions	20
Water container.....	20
Drip tray	20
Temperature	20
Cooking duration	20
Noises	20
PreHeating phase.....	21
Cooking phase.....	21
Steam reduction.....	21
Oven interior lighting	21
Before using for the first time	22
General settings	22
Cleaning for the first time.....	23
Setting the water hardness level.....	24
Setting the correct boiling point for water	24
Modes / Programs / Menus	25
Operation	26
Quick Guide	26
Interrupting operation	27
Additional functions	28
Setting additional durations	28
Turning on and off automatically.....	28
Sequence of an automatic cooking process	29
Changing settings during a cooking process	29
Canceling cooking	30
Sous-vide (vacuum) cooking	31
MasterChef	36
List of food types	36
Using the MasterChef programs.....	37

Favorites	38
Creating a Favorite	38
Starting a Favorite	39
Changing Favorites	40
Changing cooking stages	40
Changing the name	40
Deleting a Favorite	41
Timer	42
Setting the timer	42
Resetting the timer	42
Canceling the timer	42
General notes	43
The advantages of cooking with steam	43
Suitable containers	43
Cooking pan	43
Your own containers	43
Drip tray	43
Shelf level	44
Frozen food	44
Temperature	44
Cooking duration	44
Cooking with liquid	44
Your own recipes	44
Steam cooking	45
Vegetables	45
Meat	48
Sausage	50
Fish	50
Shellfish	53
Mussels	54
Rice	55
Pasta	56
Dumplings	57
Grains	58
Legumes	59
Eggs	61
Fruit	62
Menu Cooking - Manual	63
Special modes	65
Reheat	65

Contents

Defrost	66
Canning.....	69
Juicing.....	72
Menu Cooking.....	73
Making Yogurt.....	74
Proofing.....	75
Dissolving Gelatine	76
Melting Chocolate.....	76
Skinning Fruits and Vegetables.....	77
Preserving Apples	77
Blanching	78
Sweating Onions.....	78
Rendering Fat.....	79
Sanitizing Cookware	79
Heating Damp Towels.....	80
Decrystallizing Honey	80
Preparing Custard Royale.....	80
Settings	81
Accessing the "Settings" menu	81
Changing and saving settings	81
Settings overview.....	82
Language 	83
Time of day	83
Display	83
Clock format	83
Set.....	83
Date.....	84
Lighting	84
Display brightness	84
Acoustic tone information.....	84
Melody	84
Solo tone.....	84
Keypad tone.....	85
Units of measurement.....	85
Weight.....	85
Temperature.....	85
Keeping Warm	86
Default temperatures.....	86
Safety	87
System lock 	87
Sensor lock	87
Water hardness.....	87

Contents

Showroom Program	88
Demo Mode	88
Factory default	88
Cleaning and care	89
Important information on cleaning and care	89
Appliance front.....	90
Oven interior.....	91
Water container.....	91
Accessories	92
Shelf runners	92
Descaling	93
Door	95
Frequently asked questions	97
Optional accessories	99
Cooking pan.....	99
Cleaning and care products.....	101
Additional accessories	101
IMPORTANT SAFETY INSTRUCTIONS - INSTALLATION	102
Detailed dimensions of oven front	103
Installation dimensions.....	104
Installation into a tall cabinet	104
Undercounter installation.....	105
Installation in combination with an oven.....	106
Installation	107
Electrical connection	108
Power Supply.....	108
Caring for the environment	109
Technical service, data plate, warranty	110
MieleCare.....	111

IMPORTANT SAFETY INSTRUCTIONS

When using the steam oven, follow basic safety precautions, including the following:

Read all instructions before installation and use of the appliance to prevent accidents and machine damage.

This appliance conforms to current safety requirements. Inappropriate use can, however, lead to personal injury and damage to property.

To avoid the risk of accidents and damage to the appliance, please read these instructions carefully before installing or using it for the first time. They contain important notes on installation, safety, use and maintenance.

Keep these instructions in a safe place and pass them on to any future owner.

IMPORTANT SAFETY INSTRUCTIONS

Use

- ▶ This appliance is intended for residential use only.
- ▶ The steam oven is not suitable for outdoor use.
- ▶ This steam oven is intended for domestic use only as described in these operating instructions.
Any other usage is not supported by the manufacturer and could be dangerous.
- ▶ Persons who lack physical, sensory or mental abilities, or experience with the appliance should not use it without supervision or instruction by a responsible person.

IMPORTANT SAFETY INSTRUCTIONS

Children

- ▶ Activate the system lock to ensure that children cannot switch on the steam oven inadvertently.
- ▶ Children must not be allowed to clean the steam oven unsupervised.
- ▶ Please supervise children in the vicinity of the steam oven and do not let them play with it.
- ▶ Danger of suffocation! Ensure that any plastic wrappings, bags, etc. are disposed of safely and kept out of the reach of children.
- ▶ Danger of burning. Children's skin is far more sensitive to high temperatures than that of adults. Make sure that children do not attempt to open the door when the appliance is in operation. Keep children well away from the appliance until it has cooled down and there is no danger of burning.
- ▶ Risk of injury! The maximum allowable weight on the door is 17.5 lbs (8 kg).
Do not allow children to hang, lean or sit on the door when open.
- ▶ Children should not be left alone or unattended in the area where the steam oven is in use. They should never be allowed sit or stand on any part of the appliance.

IMPORTANT SAFETY INSTRUCTIONS

Technical safety

- ▶ Installation, repair and maintenance work should be performed by a Miele authorized service technician in accordance with national and local safety regulations and the provided installation instructions. Contact Miele's Technical Service Department for examination, repair or adjustment. Repairs and other work by unauthorized persons could be dangerous and may void the warranty.
- ▶ A damaged appliance is dangerous. Check the appliance for any visible damage. Never install or attempt to use a damaged appliance.
- ▶ Reliable and safe operation of this steam oven can only be assured if it has been connected to the mains electricity supply.
- ▶ Be certain your appliance is properly installed and grounded by a qualified technician. To guarantee the electrical safety of this appliance, continuity must exist between the appliance and an effective grounding system. It is imperative that this basic safety requirement be met. If there is any doubt, have the electrical system of the house checked by a qualified electrician.
- ▶ Before connecting the appliance to the mains supply, ensure that the connection data on the data plate (voltage and frequency) match the mains electricity supply.
This data must correspond in order to avoid the risk of damage to the appliance. Consult a qualified electrician if in any doubt.
- ▶ Do not use an extension cord to connect this appliance to the power supply. Extension cords do not guarantee the required safety of the appliance.
- ▶ For safety reasons, this appliance may only be used after it has been built in.
- ▶ This steam oven must not be used in a non-stationary location (e.g. on a ship).

IMPORTANT SAFETY INSTRUCTIONS

- ▶ Tampering with electrical connections or components and mechanical parts is highly dangerous to the user and can cause operational faults. Do not open the outer casing of the appliance.
- ▶ While the appliance is under warranty, repairs should only be performed by a Miele-authorized service technicians. Work by unqualified persons could be dangerous and may void the warranty.
- ▶ Defective components should be replaced by Miele original parts only. Only with these parts can the manufacturer guarantee the safety of the appliance.
- ▶ If the plug has been removed or the power cord is not supplied with a plug, the steam oven must be connected to the power supply by a suitably qualified electrician.
- ▶ Do not operate the appliance if the power cord is damaged. It must be replaced by a suitably qualified electrician with a H 05 VV-F (PVC-insulated) type power cord, available from Miele.
- ▶ Before installation, maintenance, and repair work, the steam oven must be disconnected from the electrical supply. It is only completely isolated from the electrical supply if: the fuse has been removed (where applicable), the main circuit breaker has been tripped, or the power cord has been unplugged from the wall outlet. Always be sure to pull the plug not the cord.
- ▶ If the steam oven is installed behind a cabinet door, do not close the door while the appliance is in operation. Heat and moisture can build up behind the closed door and cause damage to the range and to the surrounding cabinets and flooring. Do not close the door until the appliance has completely cooled down.
- ▶ Do not repair or replace any part of the appliance unless specifically recommended in the manual. All other servicing should be referred to a qualified technician.

IMPORTANT SAFETY INSTRUCTIONS

- ▶ Do not operate any appliance with a damaged cord or plug, or if the appliance has been damaged in any manner. Contact Miele's Technical Service Department.

IMPORTANT SAFETY INSTRUCTIONS

Proper use

- ▶ Danger of burning. The steam oven becomes hot when in use. You could burn yourself on the heating elements, oven interior, cooked food, oven accessories or hot steam. Use pot holders when placing food in the oven or removing it and when adjusting oven shelves etc. in a hot oven.
Take care when putting cooking pans into the oven or removing them not to spill the contents.
- ▶ Danger of burning. There will be some residual hot water in the steam generator at the end of a cooking process. This will be pumped back into the water container. Take care not to spill the contents when taking the water container out of the appliance.
- ▶ Do not heat up food in closed containers e.g. tins or sealed jars in the steam oven, as pressure will build up in the container, causing it to explode.
- ▶ Plastic dishes which are not heat- and steam resistant melt at high temperatures and can damage the appliance.
Use temperature- (up to 212°F / 100°C) and steam-resistant plastic dishes. Follow the manufacturer's instructions.
- ▶ Food which is left in the oven to be kept hot can dry out and the moisture released can lead to corrosion damage in the appliance.
Do not use the steam oven for keeping food warm and do not use utensils in the appliance which could corrode.
- ▶ Do not leave the appliance door open unnecessarily as someone may trip over it or be injured by it.
- ▶ The door can support a maximum weight of 17.5 lbs (8 kg). Do not sit, lean or place heavy items on the open oven door. Also be sure nothing can get trapped between the door and the oven cavity.
The steam oven could get damaged.

IMPORTANT SAFETY INSTRUCTIONS

- ▶ When using an electrical appliance, e.g., a hand-held mixer, near the steam oven, make sure that the power cord does not get caught in the door. The insulation on the cord could become damaged, giving rise to an electric shock hazard.
- ▶ The steam oven should be installed at a safe height for users to safely access all cooking levels and pans. Otherwise spills could cause burns or scalding and children may be put at risk by the hot appliance door.
- ▶ Flammable materials should not be stored in an oven or in the vicinity of the cooktop.
- ▶ Use care when opening the door - let hot air or steam escape before removing or replacing food.
- ▶ Never use the steam oven for warming or heating the room.
- ▶ Keep the oven vent ducts open.
- ▶ Wear proper apparel - Loose-fitting or hanging garments should never be worn while using the appliance.
- ▶ Always place oven racks and containers in desired location while the oven is cool. If they must be removed while the oven is hot, do not let the potholders contact hot heating elements in the oven.

IMPORTANT SAFETY INSTRUCTIONS

Cleaning and care

- ▶ Do not use a steam cleaner to clean this oven. Steam could penetrate electrical components and cause a short circuit.
- ▶ Scratches on the door glass can cause the glass to break. Do not use abrasive cleaners, hard sponges, brushes or sharp metal tools to clean the door glass.
- ▶ The side runners can be removed for cleaning purposes (see "Cleaning and care"). Ensure that they are replaced correctly and do not use the oven without them in place.
- ▶ To avoid corrosion on the stainless steel surfaces of the Speed Oven, remove any splashes on the interior walls of the oven from food or liquids containing salt.

Accessories

- ▶ Use only genuine original Miele parts. If parts or accessories from other manufacturers are used, the warranty will become void.

Steam oven front view

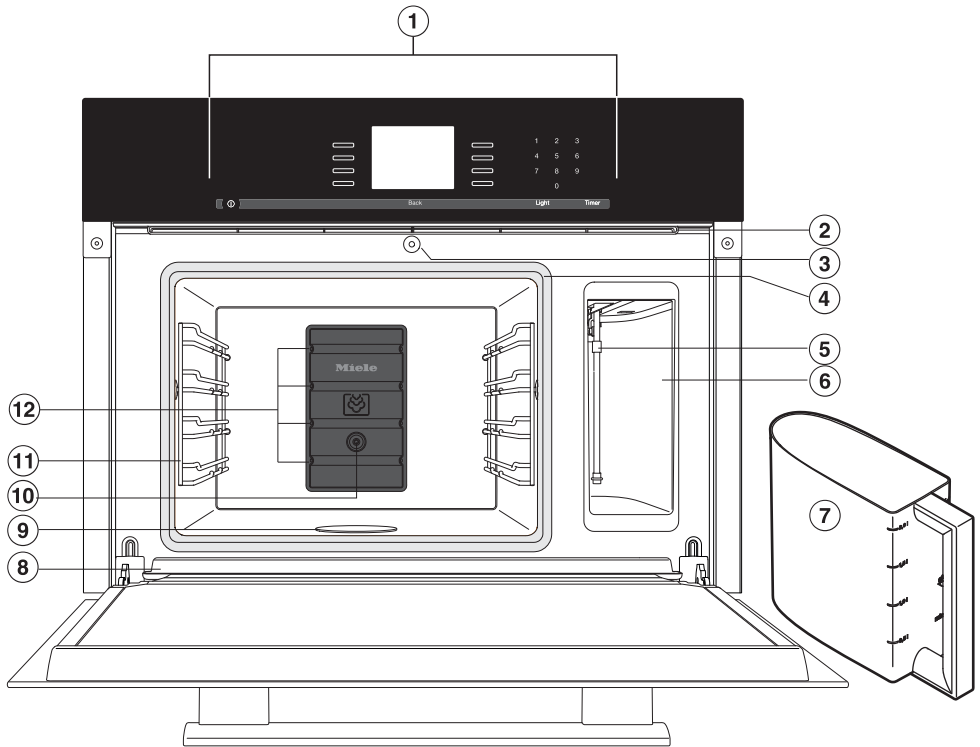

- | | |
|--|-------------------------|
| ① Control panel | ⑦ Water container |
| ② Ventilation outlet | ⑧ Drip channel |
| ③ Automatic door release for steam reduction | ⑨ Floor heating element |
| ④ Door seal | ⑩ Temperature sensor |
| ⑤ Suction tube | ⑪ Shelf runners |
| ⑥ Compartment for water container | ⑫ Steam inlet |

Overview

Included accessories

The accessories supplied with your appliance, as well as a range of optional ones, are available to order from Miele (see "Optional accessories").

DGG 21

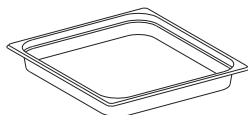

1 drip tray for collecting excess moisture, can also be used as a cooking pan.

12 3/4" x 17" x 1 1/2" (W x D x H) / 325 x 430 x 40 mm (W x D x H)

DGGL 8

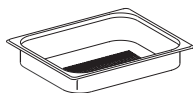

1 perforated cooking pan
12 3/4" x 10 1/2" x 1 1/2" (W x D x H) /
325 x 265 x 40 mm (W x D x H)

DGGL 1

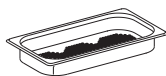

2 perforated cooking pans
12 3/4" x 7" x 1 1/2" (W x D x H) / 325 x
175 x 40 mm (W x D x H)

Wire oven rack







1 rack for your own cooking pans

Descaling tablets

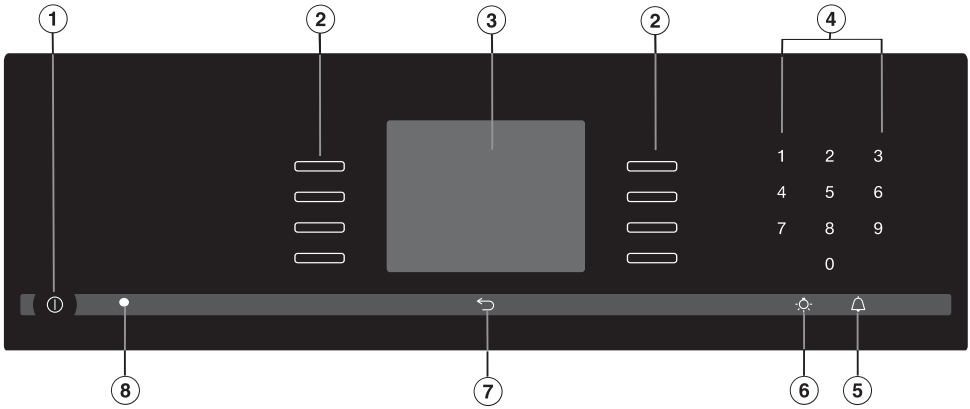
For descaling the appliance

Control panel







- ① Recessed On / Off ① button
To turn the appliance on and off
- ② Sensor buttons 
To select operating modes, settings and menu items
- ③ Display
Displays the time of day and information on operation
- ④ Sensor buttons 0-9
Numeric keypad to enter values
- ⑤  sensor button
To set the timer
- ⑥  sensor button
To turn the oven interior lighting on and off
- ⑦  sensor button
To go back one step at a time
- ⑧ Optical interface
(for service technician use only)

Control panel

Sensor buttons





The sensors react to touch. Each touch is confirmed with an audible tone. This tone can be turned off (see "Settings – Keypad tone").

Sensor button	Function	Notes
	For selecting options and scrolling through the list of options.	A menu items can be selected by touching the illuminated sensor button  next to it.
0–9	Numerical keypad for setting values	The numerical keypad is used to set values, e.g. temperatures and durations.
Timer	For setting the timer	If a list of options is showing on the display or if a cooking process is running, a timer duration (e.g. when boiling eggs) can be set at any point. If the display is dark, the "Timer" sensor button will not react until the steam oven is turned on.
Light	For turning the oven interior lighting on and off	If a menu appears on the display or if a cooking process is running, touching "Light" will turn the interior light on or off. If the display is dark, the "Light" sensor button will not react until the steam oven is turned on. The oven interior lighting turns off after 15 seconds during cooking or remains constantly turned on, depending on the setting selected.
Back	To go back a step	

- A menu item can be selected by touching the illuminated sensor  next to the menu item.
- Options can then be accessed by touching the illuminated sensor  next to OK.

Symbols

The following symbols may appear in the display:

Symbol	Description
-	Allocates an illuminated Sensor button  to an option and indicates that the option can be selected.
↓	If more than four options are available a bar will appear on the right-hand side of the display. Use the allocated sensors to scroll through the list.
.....	The end of a list is indicated by a dotted line. By scrolling down further, you will reach the beginning of the list again.
+ / -	This will only appear if an entry is possible or necessary (e.g., entry of the date).
✓	A check indicates the option which is currently selected.
i	This symbol indicates that there is additional information and advice about using the oven. Select OK to access the information.
	Start time
	Program finished
	Timer
	Some settings, e.g. display brightness and buzzer volume, are selected using a bar chart.

Description of functions

Water container

The maximum amount of water is approx. ½ gallon (2 liters), the minimum is approx. ½ pint (0.5 liters). These levels are indicated on the container. Never exceed the maximum level.

The amount of water depends on the type of food and the duration of cooking. You may need to refill the water container during the cooking procedure. Opening the door will increase the amount used.

Fill the water container to the maximum level before each use.

At the end of the cooking process, residual water in the steam generator is pumped back into the water container. The water container should be emptied after each use.

Drip tray

When you are using perforated containers, place the drip tray on the lowest shelf level to collect any drops of liquid and allow them to be removed easily.

You can also use the drip tray as a cooking pan if necessary.

Temperature

Some programs have a default recommended temperature. This temperature can be altered for the program in use or for every use of that program (see "Settings - Recommended Temperatures").

Cooking duration

You can set a duration between 1 minute (0:01) and 10 hours (10:00). If the duration exceeds 59 minutes you have to enter it in hours and minutes. Example: Duration 80 minutes = 1:20.

Noises

You will hear a pumping sound when the appliance is turned on, during use and after turning it off. This is the sound of water being pumped through the system and is quite normal.

When the steam oven is in use, you will hear a fan noise.

PreHeating phase

During the preheating phase, the display will show the rising temperatures and PreHeating (exception: MasterChef, Menu Cooking, and Descale).

The duration of the preheating phase will depend on the quantity and the temperature of the food. In general this phase will last for approx. 5 minutes. The duration will be longer if you are preparing refrigerated or frozen food.

Cooking phase

The cooking phase begins when the set temperature is reached. During the cooking phase, the time left will be shown on the display.

Steam reduction

The appliance door will open a fraction just before the end of a cooking program to release some of the steam from the cabinet. Steam Reduction will appear on the display. The door will then close automatically.

Steam reduction can be turned off (see "Settings - Steam Reduction"). If deactivated, steam will be emitted from the oven cavity when the door is opened.

Oven interior lighting

The oven light has been set at the factory to go out when cooking starts.

If you want it to stay on all the time the oven is on you will need to alter the default setting (see "Settings - Lighting").

If the door is left open at the end of a cooking program, the oven lighting will turn off automatically after 5 minutes.

The lighting can be turned on for 15 seconds by pressing the  button on the control panel.

Before using for the first time

General settings

 The steam oven must not be operated until it has been correctly installed.

The steam oven will turn on automatically when it is connected to the power supply.

Welcome screen

A welcome screen is displayed. You will then be asked to select some basic settings which are needed before the appliance can be used.

- Follow the instructions on the display.

Set the language

- Scroll through the list until the desired language appears.
- Touch the illuminated  sensor button next to the language you want to select.
- Confirm with OK.

Set the country

- Scroll through the list until the desired country appears.
- Touch the illuminated  sensor button next to the country you want to select.
- Confirm with OK.

Set the date

- Use + or – to set the year, month and day.
- Confirm with OK.

Set the time of day

- Use the numerical keypad to set the time of day in hours and minutes (e.g. 1-2-1-5 for 12:15).
- Confirm with OK.

The time of day can be displayed in 12-hour format (see "Settings - Time of Day - Clock Format").

Before using for the first time

Time of day format

You will then be asked when you want the time of day to show on the display when the steam oven is turned off (see "Settings - Time of Day - Display"):

– On

The time is always visible on the display.

– Off

The display appears dark to save energy. Some modes are limited.

– Night Dimming

The time only shows on the display between 5:00 am and 11:00 pm. It turns off at night to save energy.

■ Select the desired option.

■ Confirm with OK.

Information regarding energy consumption will appear on the display.

■ Confirm with OK.

Set up Successfully Completed is displayed.

■ Confirm with OK.

The steam oven is ready for use.

If you accidentally select the wrong language, follow the instructions described in "Settings - Language 🗑️."

■ Please adhere the extra data plate for the appliance supplied with this documentation in the space provided in the "Technical service, data plate, warranty" section of this manual.

■ Remove any protective foil and stickers.

The appliance has undergone a function test in the factory. Residual water from this testing may have dripped from the lines into the oven cavity during transportation.

Cleaning for the first time

Water container

■ Take the water container out of the appliance and rinse it by hand.

Accessories / Oven interior

■ Remove all accessories from the steam oven.

■ Wash the accessories in a mild solution of warm water and liquid dish soap or in the dishwasher.

The interior of the steam oven has been treated at the factory with a conditioning agent.

■ To remove this, clean the oven interior with a mild solution of warm water and liquid dish soap and then dry thoroughly with a soft cloth.

Before using for the first time

Setting the water hardness level

The steam oven is factory set for Hard water. It must be adjusted to local water hardness to ensure trouble-free operation and to ensure that descaling is carried out at the correct interval. The harder the water, the more often it will need to be descaled.

- Check the hardness of your local water supply and adjust the water hardness as necessary (see "Settings - Water Hardness").

Setting the correct boiling point for water

Before cooking food for the first time, you must set the boiling point for water, as this varies depending on the altitude the appliance is located at. This procedure also flushes out the waterways.

This procedure **must** be carried out to ensure efficient functioning of your appliance.

- You should then run the steam oven with Steam Cooking (212°F / 100°C) for 15 minutes. Proceed as described in "Operation."

Resetting the correct boiling point for water

If you move, the appliance will need to be re-set for the new altitude if this differs from the old one by 300 m or more. To do this, descale the appliance (see "Cleaning and care / Maintenance / Descaling").

Modes / Programs / Menus

	Recommend- ed tempera- ture	Temperature range
Steam Cooking Retains the flavor and nutrients of the food without added fats or oils	212°F / 100°C	105-212°F / 40-100°C
Sous-vide Cooking food in a vacuum bag	150°F / 65°C	115-195°F / 45-90°C
MasterChef The list of available MasterChef programs is displayed.		
Special Modes		
Menu Cooking Simultaneous cooking of various foods	–	–
Defrost For gentle defrosting of frozen foods	140°F / 60°C	120-140°F / 50-60°C
Reheat For gentle reheating of cooked food	212°F / 100°C	175-212°F / 80-100°C
Blanching	–	–
Canning	195°F / 90°C	175-212°F / 80-100°C
Sanitize Cookware	–	–
Proof	–	–
Favorites Create and save your favorite dishes		
Settings  Changing the factory default settings		
Descalc	–	–

Operation

Quick Guide

- Turn the steam oven on ①.

The main menu appears on the display.

Only use cold tap water (less than 68°F / 20°C). Never use distilled or mineral water or other liquids.

- Push the water container into the appliance until it engages.
- Put the food in the oven.
- Select Steam Cooking.

Set the Temperature appears on the display.

- Adjust the recommended temperature if necessary.

The recommended temperature will be automatically accepted within a few seconds.

If necessary, select ↵ to go back to the temperature setting (see "Additional Functions - Changing the Temperature").

- Confirm with OK.

Set the Duration appears on the display.

- Set the cooking duration. Any time between 1 minute and 10 hours can be set.
- Confirm with OK.

The cooking process begins. The steam condenser, lighting, and fan turn on.

If you are cooking at a temperature of approx. 175°F / 80°C, Steam Reduction will appear on the display shortly before the end of the cooking time and the door will open a little.

At the end of the cooking time

- Program Finished appears on the display.
- The fan remains on.
- A buzzer or melody will sound (see "Settings - Acoustic tone information").

You have the option to save the program as a Favorite (see "Favorites") or to increase the cooking duration using ändern. Select ↵ to go back to the main menu.

⚠ Burn hazard!

You could burn yourself on the oven interior walls, spilled food and accessories

Use pot holders when removing hot food from the oven.

- Wait until Steam Reduction goes out on the display before opening the door and removing the food.
- Turn the steam oven off ①.

A new cooking process can only be started if the automatic door opener is retracted into its original position. Do not push it in manually as this could damage it.

After use

- Remove the drip tray and empty it.

- Remove the water container and empty it.
- After each use, clean and dry the whole appliance as described in "Cleaning and Care."
- Leave the appliance door open until the oven interior is completely dry.

Insufficient water

If the steam oven runs out of water during operation, an audible tone will sound and the display will prompt you to fill the water container with fresh tap water.

- Remove the water container and fill it with fresh tap water.
- Push the water container into the appliance until it connects.
- Close the door.

Operation will continue.

Interrupting operation

Operation is interrupted as soon as the door is opened. The heating will be turned off and the cooking duration remaining stored in memory.



Burn hazard!

Steam can escape when the door is opened.

Step back and wait until the steam has dissipated.



Burn hazard!

You could burn yourself on the oven interior walls, spilled food and hot steam.

Use pot holders when inserting, removing or turning hot food, or when adjusting shelves, etc. in a hot oven.

Operation will resume when the door is closed.

When the door is closed, the pressure has to equalize, which can cause a whistling sound.

The oven will heat up again and the display will show the temperature of the cooking compartment as it rises. Once the set temperature has been reached, the display will change to show the cooking duration remaining as it counts down.

The cooking process will be ended early if the door is opened during the last minute of cooking (55 seconds standing time).

Operation

Additional functions

Setting additional durations

You have placed the food in the oven, selected a temperature and a duration.

■ **Select Change.**

Additional menu items will appear. You can select or change these options for the cooking program:

- Ready at
- Start at

You can set the program to turn off or on and off automatically by entering Ready at or Start at.

- Ready at

You specify the time you want cooking to stop.

- Start at

You specify the time you want cooking to start.

Cooking results can be impaired if there is a long delay between the food being placed in the oven and the start of cooking. Fresh food can change its color and even deteriorate.

If the temperature in the oven is too high, e.g. directly after another program, you will not be able to use this function. Ready at and Start at will not appear on the display if this is the case. Open the oven door until the appliance has cooled down.

Turning on and off automatically

To turn a cooking program on and off automatically, you have a choice of how to enter the time parameters:

- Duration and Ready at
- Duration and Start at

Example: It is now 11:45 am. The food takes 5 minutes to cook and needs to be ready at 12:30 pm.

■ **Select Change.**

■ **Select Duration and set a duration of "00:05."**

■ **Select Ready at and set "12:30."**

■ **Confirm with OK.**

Start at is calculated automatically. The cooking duration entered is added to the preheating time calculated by the steam oven.

Start at 12:18 appears on the display. The cooking process will start automatically at this time.

Sequence of an automatic cooking process

Up until the start time the mode, the selected temperature, Start at and the start time will appear in the display.

After the program has started you can follow the preheating phase on the display until the required temperature has been reached.

As soon as this temperature is reached, a buzzer or melody will sound (see "Settings - Acoustic tone information").

After the preheating phase, the cooking time (time left) will count down on the display. The last minute counts down in seconds.

Shortly before the end of the cooking procedure, Steam Reduction appears (only in case of a temperature from about 175°F / 80°C).

At the end, the steam generator and light turn off. Program Finished appears and a buzzer or melody will sound (see "Settings - Acoustic tone information").

You have the option to save the program as a Favorite (see "Favorites") or to increase the cooking duration using Change. Select "Back" to go back to the main menu.

Changing settings during a cooking process

- Select Change.

The following will appear on the display:

- Temperature
- Duration
- Ready at
- Start at

If the temperature in the oven is too high Ready at and Start at are not displayed.

- Change Mode

Changing the temperature

- Select Temperature.
- Change the temperature.
- Confirm with OK.

The program will restart with the changed temperature.

You can also permanently reset the recommended temperature to suit your personal cooking habits (See "Settings - Recommended Temperatures").

Changing the cooking duration

- Select Duration.
- Change the duration.
- Confirm with OK.

The program will restart using the new duration.

Operation

Deleting a finish time

- Select Ready at.
- Select Reset.
- Confirm with OK.

The finish time is now deleted.

The program will start using the duration set.

Changing the oven mode

You can switch to the Steam Cooking and Sous-vide modes.

- Select Change Mode.
- Select the desired mode.

The new mode will appear on the display together with its recommended temperature.

- Change the temperature, if necessary.
- Confirm with OK.
- Change the cooking duration, if necessary.
- Confirm with OK.

The oven mode has been changed.

The Change Mode function is available in the following special applications:

- Defrost
- Reheat
- Blanching
- Canning
- Sanitize Cookware
- Proof

Canceling cooking

- Select ↶.

Cancel Cooking? appears on the display.

- Select Yes.

The Main Menu will appear. Any cooking durations set will be deleted.

Sous-vide (vacuum) cooking

This gentle cooking method allows food to be cooked slowly at a low, constant temperature in vacuum packaging.

With vacuum cooking, moisture does not evaporate and all nutrients and flavors are retained.

The result is flavorful and cooked evenly.

Only use food that is fresh and in good condition.

Ensure hygienic conditions and that food has not been out of the refrigerator too long, e.g. during transportation.

Use only heat-stable, boiling-resistant vacuum bags.

Do not cook food in the manufacturer's packaging, such as vacuum-packed frozen food. It is possible that an unsuitable vacuum bag was used.

Use the vacuum bag only once.

Vacuum-seal the food only with a sous-vide vacuum sealer that guarantees a full vacuum of 99.8%.

Sous-vide (vacuum) cooking

Important usage information

To obtain an optimum cooking result, observe the following information:

- Use less herbs and spices than for conventional cooking since the influence on the taste of the food is more intensive.
You can also prepare the food unseasoned and add seasonings after cooking.
- The cooking duration reduces when salt, sugar, and liquids are added.
- The food becomes firmer with the addition of acidic ingredients, such as lemon or vinegar.
- Do not use alcohol or garlic as an unpleasant taste may result.
- Only use vacuum bags that match the size of the food. If the vacuum bag is too big, too much air may remain inside.
- If you want to cook several foods in one vacuum bag, put the food in the bag one next to the other.
- If you want to cook several vacuum bags at once, put the bags on the shelf one next to the other.
- The cooking durations depend on the thickness of the food.
- In case of higher temperatures and/or longer cooking durations, a lack of water may occur. Check the display now and then.
- Keep the door closed during the cooking procedure. Opening the door extends the cooking process and can change the cooking result.

Tips

- Freeze liquids such as marinades before vacuum-sealing to prevent them from escaping from the vacuum bag.
- Fold the edges of the vacuum bag outwards for filling in order to obtain clean, perfect weld seams.
- If you do not want to eat the food directly after cooking, put it in an ice bath and then store it at a maximum of 37°F / 3°C. In this way, you can maintain quality and taste while extending the life of the food..
- After cooking, cut the vacuum bag on all sides to access the food better.
- Briefly sear meat and fish before serving.
- Serve the food on preheated plates.

Sous-vide (vacuum) cooking

Method

- Put the food in a vacuum bag and add spices or liquid if desired.
- Vacuum-seal the food with the sous-vide vacuum sealer.
- Lay the vacuum-sealed food on the shelf (next to each other in the case of several bags).
- Select Sous-vide.
- Adjust the recommended temperature if necessary.
- Confirm with OK.
- Set the cooking duration. Any time between 1 minute and 10 hours can be set.
- Confirm with OK.

Possible causes for poor results

The vacuum bag opened:

- The weld seam was not clean or stable enough and dissolved.
- The bag was damaged by a sharp bone.

The food has an unpleasant or strange taste:

- The food was stored incorrectly.
- Your hands or counter were not perfectly clean.
- Too much spice was used.
- The bag or weld seam were damaged.
- The vacuum was under 99.8%
- The food was not immediately eaten or cooled after cooking.

Sous-vide (vacuum) cooking

Food	Added in advance		🌡️ [°F / °C]	Cooking time in minutes
	Sugar	Salt		
Fish				
Cod filet, 1" (2.5 cm) thick		x	130 / 54	35
Salmon filet, 1 1/4" (3 cm) thick		x	125 / 52	30
Monkfish filet		x	145 / 62	18
Vegetables				
Cauliflower florets, medium to large		x	185 / 85	40
Red kuri squash in slices		x	185 / 85	15
Kohlrabi in slices		x	185 / 85	30
Asparagus, white, whole	x	x	185 / 85	22–27
Sweet potatoes in slices		x	185 / 85	18
Fruit				
Pineapple in slices	x		185 / 85	75
Apple in slices	x		175 / 80	20
Baby bananas, whole			145 / 62	10
Peaches, halved	x		145 / 62	25–30
Plums, halved	x		160 / 70	10–12
Other food				
Beans, white, soaked at a 1:2 ratio (beans to liquid)		x	195 / 90	240
Shrimp, peeled and deveined		x	135 / 56	19–21
Egg, whole			149-151 / 65–66	60
Scallops, removed from shell			125 / 52	25
Shallot, whole	x	x	185 / 85	45–60
Squid tubes			165 / 75	330

🌡️ Temperature / 🕒 Cooking duration

Sous-vide (vacuum) cooking

Food	Added in advance		🌡️ [°F / °C]		Cooking time in minutes
	Sugar	Salt	Medium*	Done*	
Meat					
Duck breast, whole		x	151 / 66	162 / 72	35
Rack of lamb			136 / 58	144 / 62	50
Beef filet steak, 1 3/4" (4 cm) thick			133 / 56	142 / 61	120
Pork tenderloin, whole		x	145 / 63	153 / 67	60

🌡️ Temperature / ⌚ Cooking duration

* Degree of doneness

The "done" degree of doneness has a higher core temperature than "medium," but is not cooked through in the classical sense.

MasterChef

Your steam oven has a number of MasterChef programs that enable you to achieve excellent cooking results with ease. Simply select the appropriate program for the type of food you are cooking and follow the instructions on the display.

List of food types

The programs can be found under MasterChef.

- Vegetables
- Fish
- Meat
- Rice
- Grain
- Pasta
- Legumes
- Eggs
- Dessert
- Fruit
- Mushrooms
- Sausage
- Mussels
- Special

Using the MasterChef programs

- Select MasterChef.

A list of food types will appear on the display.

- Select the desired food category.

The MasterChef programs available for the food category selected will appear.

- Select the desired MasterChef program.

Each step you need to take before starting the MasterChef program will appear on the display.

In some programs, you will be prompted on when to add food to the oven. Follow and confirm these instructions.

Notes on using these programs

- The degree of doneness and browning levels are shown in a bar graph with seven segments. The factory default is always the middle setting. It will be highlighted. To change the setting simply move the highlighting to the left or the right.
- The weights shown refer to the weight per piece. You can cook a piece of salmon with a weight of ½ lb (250 g) or 10 pieces of salmon with a weight of ½ lb (250 g) at the same time.
- The oven interior needs to be at room temperature before starting a MasterChef program.
- When placing food in an already hot steam oven, be very careful when opening the door. Hot steam can escape. Step back from the steam oven

and wait until the steam has dissipated. When putting cooking pans or the drip tray into the oven or taking them out, take care not to spill the contents. Avoid contact with hot steam, and do not touch the hot oven interior walls. Danger of burning and scalding.

- To end a MasterChef early, turn the steam oven off completely by touching ↵.

Cancel Cooking? will appear on the display. If ja is selected, the main menu will be shown again.

- If the food is not cooked enough by the end of a MasterChef program, select Cont. Cooking.
- MasterChef programs can also be saved as Favorites.

Favorites

You can create and save up to 20 of your own programs.

- Each one can have up to 10 cooking stages. This enables you to save your favorite or most frequently used recipes very accurately. You can make individual settings for each stage.
- You can enter a program name for your recipe.

When you next select the program, it will start automatically.

There are different ways of creating a Favorite:

- At the end of running a MasterChef Program, save it as a separate program.
- After running a program with a set duration, select **Save**.

Then name the program.

Creating a Favorite

- Select **Favorites**.

When first creating a program **Create Program** will appear on the display.

If the Favorite already exists, the program name will appear with **Edit Program** underneath.

- Select **Edit Program**.
- Select **Create Program**.

You can now specify the settings for cooking stage 1.

Follow the instructions on the display:

- Select and confirm the cooking function, temperature, and duration.

The settings for the first cooking stage have now been set.

You can add additional cooking stages, e.g., if you would like to continue to cook at another temperature:

- Select **Add Cooking Stage** and proceed as for the first cooking stage.
- When you have completed setting the cooking stages. select **Complete Program**.

A summary of your settings will appear on the display.

- Check the settings and confirm with **Accept** or select **Change** to correct the settings or to add further cooking stages.
- Select **Save**.
- Enter the program name.

The following symbols appear next to the alphabet:

Symbol	Description
␣	Space
ABC	Alphabet in upper case
abc	Alphabet in lower case
123	Numbers 0 to 9 and hyphen -

- Touch the sensors next to the symbols to highlight the desired character.
- Touch **Select**.

The letter or number you have selected will appear in the top line of the display.

A maximum of 10 characters can be used.
You can delete the characters one at a time with ⬅.

- Finish creating the program name.
- Once you have entered the program name select **Save**.

A message will appear on the display confirming that your program has been saved.

- Confirm with **OK**.

You can start the saved program immediately, delay the start or change the cooking stages.

More information regarding **Change Cooking Stages** can be found in "Changing favorites".

Starting a Favorite

- Put the food in the oven.
- Select **Favorites**.

The display shows the program names and **Edit Program** at the bottom.

- Select the desired program.

You can start the saved program immediately, delay the start, or show the cooking stages.

- **Start Now**

The program will start right away and the oven heating will turn on.

- **Ready at**

You can set the time at which the cooking program should end.

- **Start at**

You can set the time at which the cooking program should start.

- **Change Cooking Stages**

The setting specified for a cooking stage can be corrected (see "Changing favorites") or more cooking stages can be added to the program.

- Select the desired mode.

The program will start according to the specified start or finish time.

Favorites

Changing Favorites

Changing cooking stages

Cooking stages in a MasterChef program that have been saved under a different name cannot be changed.

- Select Favorites.

The display shows the program names and Edit Program at the bottom.

- Select Edit Program.
- Select Change Program.
- Select the desired program.
- Select Change Cooking Stages.

A summary of your settings will appear on the display.

The setting specified for a cooking stage can be changed or more cooking stages can be added to the program.

- Change the program as desired (see "Creating favorites") and confirm by touching OK.

A summary of your settings will appear on the display.

- Select Save.
- If necessary, change the name (see "Creating favorites") and select Save.

The changes made to the program will be saved.

Changing the name

- Select Favorites.

The display shows the program names and Edit Program at the bottom.

- Select Edit Program.
- Select Change Program.
- Select the desired program.
- Select Change Name.
- Change the name (see "Creating favorites") and select Save.

A message will appear on the display confirming that the name has been saved.

- Confirm with OK.

Deleting a Favorite

- Select Favorites.

The display shows the program names and Edit Program at the bottom.

- Select Edit Program.
- Select Delete Program.
- Select the desired program.
- Confirm if the program should be deleted with Yes.

The program is deleted.

You can delete all of your Favorites at the same time (see "Settings - Factory Default - Favorites").

Timer

The timer can be used to time any activity in the kitchen, e.g. boiling eggs.

The timer can also be used at the same time as a cooking program if a start and finish time have been set, e.g. a reminder to stir the dish or add seasoning.

A maximum timer duration of 9 hours, 59 minutes and 59 seconds can be set.

Setting the timer

If you want to use the timer and Time | Show | Off has been set, you will need to switch the steam oven on before you can set the timer. The timer can then be seen counting down on the display when the steam oven is switched off.

Example: You are boiling eggs so you set the timer for 6 minutes and 20 seconds.

- Select .



"0 : 00 : 00" (h : min : sec) will appear on the display.

- Use the numerical keypad to enter a different duration (6-2-0).
- Confirm with OK.

The duration counts down on the display when the steam oven is turned off.

If a cooking program is running at the same time, the timer duration will appear at the bottom of the display.

At the end of the timer

-  flashes in the display.
- The time starts counting upwards.
- A buzzer or melody will sound (see "Settings - Acoustic tone information").
- Select  or the illuminated sensor button next to the timer to turn off the acoustic and optical signals.

Resetting the timer

- Tap  or the illuminated sensor button next to the timer duration that is counting down.

The set timer appears on the display.

- Set the new timer duration using the numeric keypad.
- Confirm with OK.

The changed timer is saved and will start to count down immediately.

Canceling the timer

- Tap  or the illuminated sensor button next to the timer duration that is counting down.

The set timer appears on the display.

- Select **Reset**.

The timer has been canceled.

The "General Notes" section contains general information. You will find more detailed information about particular foods and how to cook them in the other sections.

The advantages of cooking with steam

Almost all vitamins and minerals are retained as the food is not immersed in water.

Cooking with steam also retains the true taste of the food better than conventional cooking. We therefore recommend seasoning the food after it has been cooked. Food also retains its fresh, original color.

Suitable containers

Cooking pan

This steam oven is supplied with stainless steel cooking pans. Other containers, in a variety of sizes, both perforated and solid, are available as optional extras (see "Optional accessories"). This enables you to choose the most suitable container for the food you are preparing.

It is best to use perforated containers for steam cooking. The steam can reach the food from all sides and the food is cooked evenly.

Your own containers

You can also use your own containers. However, please note the following:

- Containers must be heat-resistant to 212°F / 100°C and able to withstand hot steam. With plastic containers please check with the manufacturer that they are suitable for use in a steam oven.
- Thick-sided containers made from porcelain, china or stoneware, for example, are not so suitable for steam cooking. They do not conduct heat well and as a result cooking durations will be considerably longer than those given in the charts.
- Place the cooking pans on the rack and not on the oven floor.
- Ensure that there is a gap between the upper rim of the container and the top of the cooking compartment to allow sufficient steam into the container.

Drip tray

When you are using perforated containers, place the drip tray on the lowest shelf level to collect any drops of liquid and allow them to be removed easily.

You can also use the drip tray as a cooking pan if necessary.

General notes

Shelf level

You can select any shelf level. You can also cook on several levels at the same time. This will not alter the cooking duration.

When using more than one deep container at the same time it is best to offset them on their runners and to leave at least one level free in between them.

Always insert cooking pans and the rack between the rails of the side runners so that they cannot tip.

Frozen food

The heating up phase for frozen food is longer than for fresh food. The greater the quantity of frozen food, the longer the preheating phase.

Temperature

A maximum temperature of 212°F / 100°C is reached when steam cooking is taking place. Most types of food will cook at this temperature. Some more delicate types of food, such as soft fruit, must be cooked at lower temperatures as otherwise they will burst. More information is given in the relevant section.

Combination with a food warming drawer

When the warming drawer is in use the oven cavity in the steam oven can get up to 104°F / 40°C. If, in this case, you set a temperature of 104°F / 40°C, no steam will be produced because the oven cavity is too warm.

Cooking duration

In general, the cooking durations for cooking with steam are the same as for cooking food in a saucepan. More information about any factors which may affect the cooking duration is given in the relevant sections.

The quantity of food does not affect the cooking time. 1 lb of potatoes will take the same time to cook as ½ lb.

The durations given in the charts are guidelines only. We recommend selecting the shorter cooking duration quoted to start with. If food is not cooked sufficiently after the shorter time it can be put back in the oven and cooked for longer.

Cooking with liquid

When cooking with liquid only fill the cooking pan $\frac{2}{3}$ full to prevent the liquid spilling when the cooking pan is removed from the oven.

Your own recipes

Food and recipes which are prepared in pot or a pan can also be cooked in the steam oven. The cooking times in the steam oven will be the same. Please note that food will not be brown or crisp when cooking with steam.

Vegetables

Fresh food

Prepare fresh vegetables in the usual way, i.e. wash, clean and cut them up.

Frozen food

Frozen vegetables do not need to be defrosted beforehand unless the vegetables have been frozen together in a block.

To cook frozen vegetables, program the same time as for fresh ones.

Break up the larger, frozen together pieces. Please refer to the cooking times on the packaging.

Cooking pan

Food such as peas or asparagus spears, which have little or no space between them, will take longer to cook because the steam has less space to work in. For an even result, it is best to use a shallow container for these types of food, and only fill it about 1-2" (3-5 cm) deep. When cooking large quantities divide the food between 2 or 3 shallow containers rather than using one deep one.

Different types of vegetables which take the same length of time to cook can be cooked together in one cooking pan.

Use solid containers for vegetables which are cooked in liquid, e.g. cabbage.

Shelf level

When cooking vegetables with a distinctive color (e.g. beets) in a perforated container at the same time as cooking other foods in other containers, place the drip tray directly underneath the perforated container to catch any drips and therefore avoid any color transfer.

Cooking duration

As with conventional methods, when cooking vegetables with steam, the cooking duration will depend on the size and also whether you want the vegetables to be al dente or soft/well done. Example:

firm potatoes, cut into quarters
= approx. 18 minutes

firm potatoes, cut in half
= approx. 22 minutes

Brussels sprouts, large, al dente =
approx. 12 minutes

Brussels sprouts, small, soft
= approx. 12 minutes

Settings

MasterChef | Vegetables | ... | Steam
Cooking

or

Steam Cooking

Temperature: 212°F / 100°C

Duration: see chart

Steam cooking

The durations given in the charts for fresh vegetables are guidelines only. We recommend selecting the shorter cooking duration quoted to start with. If vegetables are not cooked sufficiently after the shorter time, they can be put back in the steam oven and cooked some more.

Vegetables	🕒 [min]
Artichokes	32–38
Cauliflower, whole	27–28
Cauliflower, florets	8
Beans, green	10–12
Broccoli, florets	3–4
Carrots, whole	7–8
Carrots, halved	6–7
Carrots, chopped	4
Chicory, halved	4–5
Chinese cabbage, chopped	3
Peas	3
Fennel, halved	10–12
Fennel, cut into strips	4–5
Kale, chopped	23–26
Waxy potatoes, peeled whole	27–29
halved	21–22
quartered	16–18
Fairly waxy potatoes, peeled whole	25–27
halved	19–21
quartered	17–18
Floury potatoes, peeled whole	26–28
halved	19–20
quartered	15–16
Kohlrabi, cut into batons	6–7

Steam cooking

Vegetables	 [min]
Pumpkin, diced	2–4
Corn on the cob	30–35
Swiss chard, chopped	2–3
Peppers, diced / cut into strips	2
Potatoes cooked in skins, firm	30–32
Mushrooms	2
Leeks, chopped	4–5
Leek, halved lengthwise	6
Romanesco, whole	22–25
Romanesco, florets	5–7
Brussels sprouts	10–12
Red beets, whole	53–57
Red cabbage, chopped	23–26
Black salsify, whole	9–10
Celery root, cut into batons	6–7
Green asparagus	7
White asparagus, whole	9–10
Carrots, chopped	6
Spinach	1–2
Pointed cabbage, chopped	10–11
Celery, chopped	4–5
Rutabaga, chopped	6–7
White cabbage, chopped	12
Savoy cabbage, chopped	10–11
Zucchini, sliced	2–3
Snap peas	5–7

 Cooking duration

Steam cooking

Meat

Fresh food

Prepare the meat as usual.

Frozen food

Meat should be thoroughly defrosted before cooking in the steam oven (see "Defrosting").

Preparation

For meat which needs to be seared before being cooked, e.g. for a stew, sear the meat in a pan on the cooktop first.

Cooking duration

The cooking time depends on the thickness and consistency of the food. The thicker the meat, the longer the cooking time.

Tips

- Use a perforated container to retain the **flavor** when cooking meat. Place a solid container underneath to catch the juices. You can use these to make a gravy or freeze them for later use.
- Boiling chicken, pork rind, meat, ribs and meat bones can be used to make **stock**. Place the meat together with some mixed vegetables in a solid cooking pan and add cold water. The longer the cooking duration, the stronger the stock.

Settings

MasterChef | Meat | ... | Steam Cooking

or

Steam Cooking

Temperature: 212°F / 100°C

Duration: see chart

Steam cooking

The cooking times given in the chart are guidelines only. We recommend selecting the shorter cooking time to start, additional time can be added if necessary.

Meat	Cooking time in minutes
Shank, covered with water	110–120
Pork knuckle	135–140
Chicken breast filet	8–10
Leg (Joint)	105–115
Prime rib, covered with water	110–120
Veal strips	3–4
Smoked pork chops	6–8
Lamb stew	12–16
Spring chicken	60–70
Roulade of turkey	12–15
Turkey breast	4–6
Cross rib, covered with water	130–140
Beef stew	105–115
Whole chicken, covered with water	80–90
Boiled beef	110–120

⌚ Cooking time

Steam cooking

Sausage

Settings

MasterChef | Sausage | ... | Steam Cooking

or

Steam Cooking

Temperature: 195°F / 90°C

Duration: see chart

Sausage	Cooking time in minutes
Boiled sausage	6–8
Pork sausage	6–8
Veal sausage	6–8

⌚ Cooking time

Fish

Fresh food

Prepare fresh fish in the usual way, i.e. clean, gut and filet.

Frozen food

Frozen fish should be slightly defrosted before cooking.

Preparing for use

Add some lemon or lime juice to fish before cooking. The citric acid helps the flesh stay firm.

It is not necessary to season fish when cooking with steam as this method retains the minerals which give the fish its unique flavor.

Cooking pans

If using a perforated pan, grease it first.

Shelf level

When cooking fish in a perforated container at the same time as cooking other types of food in other containers, place the container with the fish directly above the tray to catch any liquid and so avoid any transfer of tastes to other food.

Temperature

185° F – 195° F / 85° C – 90° C

For gently cooking delicate types of fish, such as sole.

212° F / 100° C

For cooking firmer types of fish, e.g. cod and salmon.

Also for cooking fish in sauce or stock.

Cooking duration

The cooking duration depends on the thickness and the consistency of the food, and not on the weight.

The longer fish cooks, the firmer its flesh will become. Use the cooking durations given in the chart. If you find that the fish is not cooked sufficiently only cook it for a few minutes more.

When cooking fish in sauce or stock, we recommend that you increase the cooking duration quoted by a few minutes.

Tips

- Adding herbs and spices, such as dill, will help bring out the full flavor of the fish.
- Cook large fish in the swimming position. To help maintain the shape of the fish, place a small cup or similar upside down in the cooking pan, and arrange the fish bellyside down over the cup.

- You can use any fish scraps, e.g. fish heads, bones, tails etc to make a **fish stock**. Place the fish scraps together with some mixed vegetables in a solid cooking pan and add cold water. Cook at 212°F / 100°C for 60 to 90 minutes. The longer the cooking duration, the stronger the stock.
- **Blue fish** is fish which is cooked in water and vinegar. It is important not to damage the skin of the fish. This method is suitable for cooking carp, trout, tench, eel, and salmon. (Follow recipe instructions for the ratio of water to vinegar).

Settings

MasterChef | Fish | ... | Steam Cooking

or

Steam Cooking

Temperature: see chart

Duration: see chart

Steam cooking

The durations given in the chart are guidelines for fresh fish. We recommend selecting the shorter cooking duration quoted to start with. If the fish is not cooked sufficiently after the shorter time, it can be put back in the steam oven and cooked some more.

Fish	🌡️ [°F / °C]	Cooking time in minutes
Eel	212 / 100	5–7
Perch filet	212 / 100	8–10
Mahi Mahi filet	185 / 85	3
Trout, 1/2 lb (250 g)	195 / 90	10–13
Halibut filet	185 / 85	4–6
Cod filet	212 / 100	6
Carp, 3 lbs (1.5 kg)	212 / 100	18–25
Salmon filet	212 / 100	6–8
Salmon steak	212 / 100	8–10
Rainbow trout	195 / 90	14–17
Pangasius filet	185 / 85	3
Ocean Perch filet	212 / 100	6–8
Haddock filet	212 / 100	4–6
Flounder filet	185 / 85	4–5
Monkfish filet	185 / 85	8–10
Sole filet	185 / 85	3
Turbot filet	185 / 85	5–8
Tuna filet	185 / 85	5–10
Pike Perch filet	185 / 85	4

🌡️ Temperature / 🕒 Cooking duration

Shellfish

Preparation

Defrost frozen shellfish before cooking with steam.

Peel, clean and wash the shellfish.

Cooking pan

If using a perforated pan, grease it first.

Cooking duration

The longer shellfish are cooked, the tougher they become. Use the cooking durations given in the chart.

When cooking shellfish in sauce or stock, we recommend that you increase the cooking duration quoted by a few minutes.

Settings

MasterChef | Shellfish | ... | Steam Cooking

or

Steam Cooking

Temperature: see chart

Duration: see chart

	🌡️ [°F / °C]	Cooking time in minutes
Shrimp	195 / 90	3
Small shrimp	195 / 90	3
King prawns	195 / 90	4
Crab	195 / 90	3
Crayfish	200 / 95	10–15
Large shrimp	195 / 90	3

🌡️ Temperature / ⌚ Cooking duration

Steam cooking

Mussels

Fresh food



Warning - danger of food poisoning.

Only cook mussels which are closed. Do not eat mussels which have not opened after being cooked.

Steep fresh mussels in water for a few hours before cooking to rinse out any sand. Then scrub the mussels thoroughly to clean them.

Frozen food

Defrost frozen mussels before cooking.

Cooking duration

The longer mussels are cooked, the tougher they become. Use the cooking durations given in the chart.

Settings

MasterChef | Mussels | ... | Steam Cooking

or

Steam Cooking

Temperature: see chart

Duration: see chart

	🌡️ [°F / °C]	Cooking time in minutes
Barnacles	212 / 100	2
Cockles	212 / 100	2
Bearded mussels	195 / 90	12
Scallops	195 / 90	5
Razor clams	212 / 100	2-4
Clams	195 / 90	4

🌡️ Temperature / ⌚ Cooking duration

Rice

Rice swells when cooked and needs to be cooked in liquid. The proportion of rice to liquid will vary depending on the type of rice.

The rice absorbs all the liquid. Therefore none of the nutrients are lost.

Settings

MasterChef | Rice | ... | Steam Cooking

or

Steam Cooking

Temperature: 212°F / 100°C

Duration: see chart

	Ratio Rice to liquid	🕒 [min]
Basmati rice	1 : 1.5	15
Parboiled rice	1 : 1.5	23–25
Round grain rice		
Pudding rice	1 : 2.5	30
Risotto rice	1 : 2.5	18–19
Brown rice	1 : 1.5	26–29
Wild rice	1 : 1.5	26–29

🕒 Cooking time

Steam cooking

Pasta

Dry pasta

Dry pasta swell when cooked and needs to be cooked in liquid. The liquid must cover the pasta. Using hot liquid gives better results.

Increase the cooking time stated by the manufacturer by approx. $\frac{1}{3}$.

Fresh food

Fresh noodles and pasta, for example, from the store refrigerator, do not swell. Fresh pasta should be cooked in a greased perforated pan.

Separate any pieces of pasta which have stuck together and spread them out in the cooking pan.

Settings

MasterChef | Pasta | ... | Steam Cooking

or

Steam Cooking

Temperature: 212°F / 100°C

Duration: see chart

Fresh food	Cooking time in minutes
Gnocchi	2
Round Knoepfli	1
Ravioli	2
Spaetzle	1
Tortellini	2
Dry pasta, covered with water	
Flat pasta	14
Soup pasta	8

⌚ Cooking time

Dumplings

Ready-made dumplings in wrappers need to be covered completely with water. Otherwise they will not absorb enough water and will fall apart, even if steeped in water prior to cooking.

Cook fresh dumplings in a greased, perforated container.

Settings

MasterChef | Pasta | ... | Steam Cooking

or

Steam Cooking

Temperature: 212°F / 100°C

Duration: see chart

	Cooking time in minutes
Steamed dumplings	30
Yeast dumplings	20
Boil-in-the-bag potato dumplings	20
Boil-in-the-bag bread dumplings	18–20

⊕ Cooking time

Steam cooking

Grains

Grain swells when cooked and needs to be cooked in liquid. The proportion of grain to liquid will vary depending on the type of grain.

Grain can be cooked whole or cracked.

Settings

MasterChef | Grain | ... | Steam Cooking

or

Steam Cooking

Temperature: 212°F / 100°C

Duration: see chart

	Ratio Grain to liquid	Cooking time in minutes
Amaranth	1 : 1.5	15–17
Bulgur	1 : 1.5	9
Green spelt, whole	1 : 1	18–20
Green spelt, cracked	1 : 1	7
Oats, whole	1 : 1	18
Oats, cracked	1 : 1	7
Millet	1 : 1.5	10
Polenta	1 : 3	10
Quinoa	1 : 1.5	15
Rye, whole	1 : 1	35
Rye, cracked	1 : 1	10
Wheat, whole	1 : 1	30
Wheat, cracked	1 : 1	8

⌚ Cooking time

Legumes

Soak legumes for at least 10 hours in cold water before cooking. Soaking makes the legumes more digestible and shortens the cooking duration required. Soaked legumes must be covered with liquid during cooking.

Lentils do not need to be soaked before cooking.

With unsoaked legumes, a certain ratio of pulses to liquid is required depending on type.

Settings

MasterChef | Legumes | ... | Steam Cooking

or

Steam Cooking

Temperature: 212°F / 100°C

Duration: see chart

Soaked	
	Cooking time in minutes
Beans	
Kidney beans	55–65
Azuki beans	20–25
Black beans	55–60
Pinto beans	55–65
White beans	34–36
Peas	
Yellow peas	40–50
Green peas, shelled	27

⌚ Cooking time

Steam cooking

Unsoaked		
	Ratio Legumes to liquid	Cooking time in minutes
Beans		
Kidney beans	1 : 3	130–140
Azuki beans	1 : 3	95–105
Black beans	1 : 3	100–120
Pinto beans	1 : 3	115–135
White beans	1 : 3	80–90
Lentils		
Brown lentils	1 : 2	13–14
Red lentils	1 : 2	7
Peas		
Yellow peas	1 : 3	110–130
Green peas, shelled	1 : 3	60–70

⌚ Cooking time

Eggs

Use a perforated container to prepare boiled eggs in the steam oven.

The eggs do not need to be pierced before cooking as they are gradually warmed during the preheating phase and so do not burst when they are cooked with steam.

When using a solid container for making egg dishes such as scrambled eggs, remember to grease it first.

Settings

MasterChef | Eggs | ... | Steam Cooking

or

Steam Cooking

Temperature: 212°F / 100°C

Duration: see chart

	Cooking time in minutes
Small soft medium hard	3 5 9
Medium soft medium hard	4 6 10
Large soft medium hard	5 6–7 12
Extra large soft medium hard	6 8 13

🕒 Cooking time

Steam cooking

Fruit

Cook fruit in a solid container so that none of the juice is lost. If you wish to cook fruit in a perforated container, place a solid container directly underneath it to collect the juice.

Tip: You can use the collected juice to prepare a glaze.

Settings

MasterChef | Fruit | ... | Steam Cooking

or

Steam Cooking

Temperature: 212°F / 100°C

Duration: see chart

	Cooking time in minutes
Apple chunks	1–3
Pears chunks	1–3
Cherries	2–4
Mirabelle plums	1–2
Nectarine / Peach chunks	1–2
Plums	1–3
Quince, diced	6–8
Rhubarb pieces	1–2
Gooseberries	2–3

⌚ Cooking time

Menu Cooking - Manual

Before cooking meals with the "Menu Cooking" function, turn off the steam reduction system (see "Settings").

"Menu Cooking" is intended for cooking a whole meal containing types of food which have different cooking durations, e.g., fish filet with rice and broccoli. Each dish is placed in the oven at different times so that they are all ready at the same time.

Shelf level

When cooking fish or food with a distinctive color (e.g. beetroot) in a perforated container, place the perforated container directly above the drip tray / universal tray (depending on model) to avoid any transfer of flavor or color to other food and to prevent liquid dripping onto food below it.

Temperature

Whole meals should be cooked at a temperature of 212°F / 100°C as this is the temperature required to cook the majority of foods.

Do not cook a whole meal at the lowest temperature when different temperatures are required for different types of food, e.g. 185°F / 85°C for seabream and 212°F / 100°C for potatoes.

If the recommended cooking temperature for the food is 185°F / 85°C, for example, try cooking it at 212°F / 100°C and testing the result. Some delicate types of fish with a soft structure, e.g. sole and plaice will become very firm when cooked at 212°F / 100°C.

Cooking duration

If you are increasing the recommended temperature, shorten the cooking duration by approx. $\frac{1}{3}$.

Example

Rice	20 minutes
Tilapia filet	6 minutes
Broccoli	4 minutes

20 minutes minus 6 minutes = 14 minutes (first cooking duration: rice)

6 minutes minus 4 minutes = 2 minutes (second cooking duration: tilapia filet)

Time left = 4 minutes (third cooking duration: broccoli)

Cooking durations	20 min. - rice		
		6 min. - tilapia filet	
			4 min. - broccoli
Setting	14 min.	2 min.	4 min.

Steam cooking

Method

- Place the rice in the steam oven first.
- Set the first cooking duration: 14 minutes.
- After 14 minutes, place the tilapia in the steam oven.
- Set the second cooking duration: 2 minutes.
- After 2 minutes, place the broccoli in the steam oven.
- Set the third cooking duration: 4 minutes.

Reheat

The steam oven is very effective at reheating food gently, without drying it out or cooking it further. The food reheats evenly and does not need to be stirred during the reheating process.

You can reheat individual dishes or plated meals which have been prepared previously (e.g. meat, vegetables and potatoes).

Suitable containers

Small quantities can be reheated on a plate, larger quantities should be placed in a cooking pan.

Duration

The number of plates or containers has no bearing on the duration.

The durations listed in the chart relate to an average portion per plate/container. Increase the duration for larger quantities.

Tips

- Do not reheat large items, such as a joint of roast meat, whole. Divide it into portions and reheat these as plated meals.
- Compact items, such as stuffed peppers or roulades, should be cut in half.
- Please note that breaded items will not retain their crispness when they are reheated.
- Reheat sauces separately, except for dishes such as stew and casseroles where the sauce is part of the dish.

Method

- Cover the food with a deep plate, a lid, or with foil that is resistant to temperatures up to 212°F / 100°C and to steam.
- Then place the plate on the rack in the oven.

Settings

Special Modes | Reheat
or
Steam Cooking

Temperature: 212°F / 100°C

Duration: see chart

	Cooking time in minutes
Side dishes (pasta, rice, etc.)	8–10
Casserole	8–10
Fish filet	6–8
Meat	8–10
Poultry	8–10
Vegetables	8–10
Soup	8–10
Plated meals	8–10

⌚ duration

Special modes

Defrost

It is much quicker to defrost food in the steam oven than at room temperature.

Temperature

140°F / 60°C is the best temperature for defrosting.

Exception: 122°F / 50°C for minced meat and game

Before and after defrosting

Remove all packaging before defrosting.

Exceptions: Leave bread and baked goods in their packaging as otherwise they will absorb moisture and become soft.

Allow defrosted food to stand at room temperature after removing it from the oven. The standing time is necessary to allow the even distribution of heat.

Cooking pan

 **Danger of salmonella poisoning.**
Do not use the liquid from defrosted meat or poultry. Dispose and wash the container, the sink and your hands.

Use a perforated container with a solid container underneath it when defrosting food which will drip, such as poultry. This way food will not be lying in defrosted liquid.

Foods which don't drip can be defrosted in a solid cooking pan.

Tips

- Fish does not need to be fully defrosted before cooking. Defrost so that the surface is sufficiently thawed to take herbs and seasoning. Depending on the thickness of the fish, 2–5 minutes should be enough.
- When defrosting food which has frozen together, e.g. berries, chops, fish filets etc. separate it about half-way through the defrosting time.
- Do not refreeze food once it has thawed.
- Defrost frozen ready meals according to the instructions on the packaging.

Settings

Special Modes | Defrost
or
Steam Cooking

Temperature: see chart

Defrosting duration: see chart

Special modes

Food to be defrosted	Quantity	⌚ [°F / °C]	Cooking time in minutes	Standing time in minutes
Dairy products				
Sliced cheese	125 g/1/4 lb.	140 / 60	15	10
Quark	1/2 lb / 250 g	140 / 60	20–25	10–15
Cream	1/2 lb / 250 g	140 / 60	20–25	10–15
Soft cheese	100 g/3.5 oz.	140 / 60	15	10–15
Fruit				
Apple sauce	1/2 lb / 250 g	140 / 60	20–25	10–15
Apple chunks	1/2 lb / 250 g	140 / 60	20–25	10–15
Apricots	1 lb / 500 g	140 / 60	25–28	15–20
Strawberries	10.6 oz / 300 g	140 / 60	8–10	10–12
Raspberries / Black currants	10.6 oz / 300 g	140 / 60	8	10–12
Cherries	5.3 oz / 150 g	140 / 60	15	10–15
Peaches	1 lb / 500 g	140 / 60	25–28	15–20
Plums	1/2 lb / 250 g	140 / 60	20–25	10–15
Gooseberries	1/2 lb / 250 g	140 / 60	20–22	10–15
Vegetables				
Frozen in a block	10.6 oz / 300 g	140 / 60	20–25	10–15
Fish				
Fish filets	14 oz / 400 g	140 / 60	15	10–15
Trout	1 lb / 500 g	140 / 60	15–18	10–15
Lobster	300 g/10.6 oz.	140 / 60	25–30	10–15
Shrimp	10.6 oz / 300 g	140 / 60	4–6	5
Ready meals				
Meat, vegetables, side dishes / stew / soup	17 oz / 480 g	140 / 60	20–25	10–15
Meat				
Roast meat, sliced	4.4–5.3 oz. / 125–150 g each	140 / 60	8–10	15–20
Ground meat	1/2 lb / 250 g	125 / 50	15–20	10–15

Special modes

Food to be defrosted	Quantity	🌡️ [°F / °C]	Cooking time in minutes	Standing time in minutes
Ground meat	1 lb / 500 g	125 / 50	20–30	10–15
Stew	1 lb / 500 g	140 / 60	30–40	10–15
Stew	2 lbs / 1000 g	140 / 60	50–60	10–15
Liver	1/2 lb / 250 g	140 / 60	20–25	10–15
Saddle of hare	1 lb / 500 g	125 / 50	30–40	10–15
Saddle of venison	2 lbs / 1000 g	125 / 50	40–50	10–15
Cutlets / chops / sausage	28 oz / 800 g	140 / 60	25–35	15–20
Poultry				
Chicken	2 lbs / 1000 g	140 / 60	40	15–20
Chicken thighs	5.3 oz / 150 g	140 / 60	20–25	10–15
Chicken filet	1 lb / 500 g	140 / 60	25–30	10–15
Turkey drumsticks	1 lb / 500 g	140 / 60	40–45	10–15
Baked goods				
Puff pastries / Yeast baked goods	–	140 / 60	10–12	10–15
Cakes and cookies	14 oz / 400 g	140 / 60	15	10–15
Bread / Rolls				
Rolls	–	140 / 60	30	2
Rye bread, sliced	1/2 lb / 250 g	140 / 60	40	15
Whole grain bread, sliced	1/2 lb / 250 g	140 / 60	65	15
White bread, sliced	5.3 oz / 150 g	140 / 60	30	20

🌡️ Temperature / ⌚ Duration / ⌛ Standing time

Canning

Only use unblemished, fresh produce which is in good condition.

Glass jars

Use clean glass jars and accessories and check them for any defects. Glass jars with twist off lids or glass lids with a rubber seal are suitable.

Make sure that all the glass jars are the same size so that bottling is carried out evenly.

After you have filled the jars with the bottled produce, clean the glass rims with a clean cloth and hot water and then seal the jars.

Fruit

Sort fruit carefully, rinse it briefly but thoroughly and allow it to drain. Take great care when cleaning soft fruit as it is very delicate.

Remove any peel, stalks, cores or pits. Cut up large fruit. For example, cut apples into slices.

If you are bottling fruit with pits (e.g. plums, apricots) without removing the pits, pierce the fruit several times with a fork or wooden skewer as otherwise it will burst.

Vegetables

Rinse, clean and cut up vegetables.

Vegetables should be blanched before bottling to help them retain their color (see "Blanching").

Fill volume

Fill the glass jars with produce up to a maximum of 1 1/4" (3 cm) below the rim. Do not pack down as this would damage the cell walls of the produce. Bang the jar gently on a cloth to help distribute the contents evenly.

Use a sugar solution for fruit and a salt or vinegar solution for vegetables.

Meat and sausage

Briefly fry or cook the meat before bottling. Use the juices with some added water, or the broth in which the meat was cooked, as the liquid content of the jars. Make sure there is no grease on the rim of the jars.

When bottling sausage, only fill the jars to halfway as the meat will rise during the bottling process.

Tips

- Make use of residual heat by leaving the jars in the oven for 30 minutes after it has switched off.
- Then cover the jars with a cloth and allow to cool for approx. 24 hours.

Special modes

Method

- Place the rack on the lowest shelf level.
- Place the jars on the rack (all the same size). Ensure that they do not touch one another.

Settings

Special Modes | Canning

or

Steam Cooking

Temperature: see chart

Bottling duration: see chart

Canned goods	🌡️ [°F / °C]	⌚* [min]
Berries		
Currants	175 / 80	50
Gooseberries	175 / 80	55
Cranberries	175 / 80	55
Fruit with stones		
Cherries	185 / 85	55
Mirabelle plums	185 / 85	55
Plums	185 / 85	55
Peaches	185 / 85	55
Greengage plums	185 / 85	55
Fruit with pips		
Apples	195 / 90	50
Apple sauce	195 / 90	65
Quinces	195 / 90	65
Vegetables		
Beans	212 / 100	120

Special modes

Canned goods	🌡️ [°F / °C]	🕒* [min]
Broad beans	212 / 100	120
Gherkins	195 / 90	55
Beetroot	212 / 100	60
Meat		
Pre-cooked	195 / 90	90
Roasted	195 / 90	90

🌡️ Temperature / 🕒 Duration

* The durations quoted are for 1.0 liter /1 qt. jars. If using 0.5 liter/1 pt. jars, reduce the duration by about 15 minutes. If using 0.25 liter/1 cup jars, reduce the duration by about 20 minutes.

Special modes

Juicing

This appliance is ideal for extracting juice from soft, firm and hard fruit.

It is best to use overripe fruit, as the riper the fruit the greater the quantity of juice produced. Very ripe fruit will also produce a more intense flavor.

Preparation

Sort and rinse the fruit. Cut out any blemishes.

Remove the stalks from grapes and cherries as these are bitter. The stalks do not need to be removed from berries.

Cut larger fruit into chunks approx. 1" (2 cm) in size. The harder the fruit the smaller the pieces should be.

Tips

- Try experimenting with mild and tart flavors.
- The juice quantity and aroma are improved if sugar is added to the fruit and is allowed to soak in for several hours. We recommend 1/4 - 1/2 cup (50-100 g) sugar per 2 lbs (1 kg) of sweet fruit and 1/2 - 3/4 cup (100-150 g) sugar for 2 lbs (1 kg) tangy fruit.
- If you wish to bottle the juice rather than consume it straight away, while still hot pour it into clean bottles and seal immediately.

Method

- Put the prepared fruit (cleaned, washed, chopped etc.) into a perforated cooking pan.
- Place a solid pan or the drip tray underneath to catch the juice.

Settings

Steam Cooking

Temperature: 215°F / 100°C

Duration: 40-70 minutes

Menu Cooking

You can cook up to three different types of food, e.g. fish with a side dish and vegetables.

The food can be selected in any order you like. The appliance will automatically sort them out in order of cooking duration required. The one with the longest duration goes in the oven first.

The Ready at and Start at functions are not available for "Menu Cooking."

the preheating phase, the display will show when the next food type is to be placed in the oven. When the time for the next food type to be placed in the oven is reached, the display will show the food type and the shelf runner. This process will be repeated for the third food type.

You can still cook food types not listed on the display together. See "Menu Cooking - manually" for details on how to do this.

Method

- Turn the steam oven on.
- Fill the water container and push it back in so that it engages.
- Then place the drip tray / universal tray (depending on model) in the appliance.
- Select Special Modes | Menu Cooking
- Select the type of food.

Depending on the food, you will be asked about the size and the degree of doneness.

- Select or enter the values required and then confirm your selection with OK.
- Select Add next ingredient.
- Select the food you want and proceed in the same way as with the first ingredient.
- Repeat the procedure, if necessary, for the third ingredient.

After you have confirmed Start Menu Cooking, the display will tell you which food to put in the oven. At the end of

Special modes

Making Yogurt

To make yogurt, you will need either fresh live yogurt or yogurt culture, obtainable from health food stores.

Use natural yogurt with live culture and without additives. Do not use heat-treated yogurt.

The yogurt must be fresh (short storage time).

You can use either pasteurized or fresh whole milk. Pasteurized milk can be used without any further treatment. Fresh milk must first be heated to 195° F / 90° C (not boiled!) and then cooled down to 95° F / 35° C. Fresh milk will give a firmer yogurt than long-life milk.

The yogurt and milk should have the same percentage fat.

Do not move or shake the jars while the yogurt is thickening.

After preparing the yogurt, it must be immediately placed in the refrigerator to cool down.

The firmness, fat content and cultures used in the yogurt starter all affect the consistency of homemade yogurt. Not all yogurts are equally suitable as yogurt starters.

Possible causes for poor results

Yogurt is not set:

Incorrect storage of the yogurt starter, too much time out of the refrigerator, packaging was damaged, milk was insufficiently heated.

Liquid has not been removed:

Jars were moved, yogurt was not cooled down quickly enough.

Yogurt is grainy:

Milk was overheated or in poor condition, milk and starter yogurt not evenly stirred.

Tip: When using yogurt enzyme, yogurt can be made from a milk / cream mixture. Mix $\frac{3}{4}$ liter/3 cups milk with $\frac{1}{4}$ liter/1 cup cream.

Method

- Mix ½ cup (100 g) yogurt with 4 cups (1 liter) of milk or make up the mixture with yogurt starter powder, following the instructions on the packaging.
- Pour the mixture into glass jars and seal them.
- Place the sealed jars in a cooking pan. Ensure that they do not touch one another.
- Immediately after the yogurt has been made, place the jars in the refrigerator, taking care not to move them unnecessarily.

Settings

MasterChef | Special | Make Yogurt

or

Steam Cooking

Temperature: 105°F / 40°C

Duration: 5 hours

Proofing

Method

- Prepare the dough according to the recipe.
- Place the dough in a covered bowl on the rack.

Settings

Special Modes | Proof

Duration: as per recipe instructions

or

Steam Cooking

Temperature: 105°F / 40°C

Duration: as per recipe instructions

Special modes

Dissolving Gelatine

Method

- **Gelatine sheets:** Completely cover the gelatine sheets with cold water and leave to soak for 5 minutes. Remove the gelatine sheets from the bowl and squeeze them out. Empty the bowl. Place the squeezed gelatine sheets back in the bowl.
- **Gelatine powder:** Place the gelatine powder in a bowl and add water according to the instructions on the packaging.
- Cover the bowl and place on the rack.

Settings

MasterChef | Special | Dissolve Gelatine

or

Steam Cooking

Temperature: 195°F / 90°C

Duration: 1 minute

Melting Chocolate

You can use the steam oven for melting any type of chocolate.

Method

- Break the chocolate into small pieces. Leave chocolate cake covering in its packaging, and place in a perforated cooking pan.
- Place large quantities in a solid container and small quantities in a cup or a bowl.
- Cover the container or the dish with a lid or with foil that is resistant to temperatures up to 212°F / 100°C and to hot steam.
- Stir large quantities once during cooking.

Settings

MasterChef | Special | Melt Chocolate

or

Steam Cooking

Temperature: 150°F / 65°C

Duration: 20 minutes

Skinning Fruits and Vegetables

Method

- Cut a cross in the top of tomatoes, nectarines etc. This will allow the peel to be removed more easily.
- Place the food in a perforated container.
- For almonds, it is important to plunge them into cold water as soon as they are taken out of the oven otherwise the skin cannot be removed.

Settings

Steam Cooking

Temperature: 212°F / 100°C

Duration: see chart

Food	Duration in minutes
Apricots	1
Almonds	1
Nectarines	1
Bell Peppers	4
Peaches	1
Tomatoes	1

⌚ duration

Preserving Apples

You can treat homegrown apples in the steam oven to increase the length of time for which you can store them.

Once treated, the apples will keep for 5 to 6 months when stored in a dry, cool and well-ventilated place. This method is only suitable for apples and not for other types of fruit.

Settings

MasterChef | Fruit | Apples | Whole | Preserving

or

Steam Cooking

Temperature: 125°F / 50°C

Duration: 5 minutes

Special modes

Blanching

Blanch fruit and vegetables before freezing them. Blanching helps maintain the quality of the produce when it is frozen.

Blanching vegetables also helps them retain their original color.

Method

- Put the prepared vegetables (cleaned, washed, chopped etc.) into a perforated cooking pan.
- Once blanched, plunge the vegetables into ice cold water to cool them down quickly. Drain them well.

Settings

Special Modes | Blanching

or

Steam Cooking

Temperature 212°F / 100°C

Duration: 1 minute

Sweating Onions

Sweating means cooking the onions in their own juices, with the addition of a little fat if necessary.

Method

- Cut the onions up into small pieces and place them in a solid cooking pan with a little butter.
- Cover the container or the dish with a lid or with foil that is resistant to temperatures up to 212°F / 100°C and to hot steam.

Settings

MasterChef | Special | Steam Onions

or

Steam Cooking

Temperature: 212°F / 100°C

Duration: 4 minutes

Rendering Fat

The bacon will not become brown.

Method

- Place the bacon (diced or rashers) in a solid cooking pan.
- Cover the container with a lid or with foil that is temperature resistant up to 212°F / 100°C and to steam.

Settings

MasterChef | Special | Render Fat

or

Steam Cooking

Temperature: 212°F / 100°C

Duration: 4 minutes

Sanitizing Cookware

The steam oven will sanitize baby bottles and other cookware. Check beforehand that the manufacturer guarantees all components are to be heat resistant to 212° F / 100 °C and also steam resistant follow manufacturers instructions.

Dismantle, clean and thoroughly rinse baby bottles. Reassemble the bottles only after they have completely dried. This prevents recontamination.

Method

- Place the individual parts in a perforated cooking pan, ensuring that they do not touch one another (on their sides or with the opening facing downwards). This will allow the steam to reach the parts from all sides.
- Place the cooking pan on the lowest shelf level.

Settings

Special Modes | Sanitize Cookware

Duration: 1 minute to 10 hours

or

Steam Cooking

212°F / 100°C

Duration: 15 minutes

Special modes

Heating Damp Towels

Method

- Moisten the towels and then roll them up.
- Place them beside one another in a perforated cooking pan.

Settings

MasterChef | Special | Heat Damp Towels

or

Steam Cooking

Temperature: 160°F / 70°C

Duration: 2 minutes

Decrystallizing Honey

Method

- Loosen the lid and place the jar of honey in a perforated cooking pan.
- Stir the honey once during the cooking procedure.

Settings

MasterChef | Special | Decrystallize Honey

or

Steam Cooking

Temperature: 140°F / 60°C

Duration: 90 minutes (irrespective of the size of jar or the amount of honey in the jar)

Preparing Custard Royale

Method

- Mix 6 eggs with 1/2 cups / 375 ml milk (do not beat until foamy).
- Season the egg/milk mixture and pour into a solid cooking pan greased with butter.

Settings

Steam Cooking

Temperature: 212°F / 100°C

Duration: 4 minutes

Accessing the "Settings" menu

- Select Settings .

A list of settings will appear in the display.

They can be checked and changed, if needed.

A check  next to an option shows which setting is active.







Settings cannot be altered while a cooking program is in progress.

Changing and saving settings

- Select Settings .
- Scroll through the list until the desired setting appears.
- Touch the sensor next to the setting. The desired setting may appear in a sub menu.
- Change the setting.
- Confirm with OK.
- Tap "Back" until the main menu appears or select another setting.

Settings

Settings overview

Option	Available settings
Language 	... / deutsch / english / ... Country
Time	Show On / Off * / Night Dimming Clock Format 24 h / 12 h * Set
Date	
Lighting	On / On for 15 Seconds *
Display Brightness	
Audible tone information	Melody  Solo Tone 
Keypad Tone	
Units of Measurement	Weight g * / lb / lb/oz Temperature °C * / °F
Keeping Warm	On / Off *
Steam Reduction	On * / Off
Default Temperature	
Safety	System Lock  On / Off * Sensor Lock On / Off *
Water Hardness	Soft
	Medium
	Hard *
Showroom Program	Demo Mode On / Off *
Factory Default	Settings Favorites Default Temperature

* Factory default

Language

The desired country and language can be set.

After selecting and confirming your choice, the language selected will appear in the display.



Tip: If you accidentally select a language you do not understand, select the  symbol to return to the submenu.

Time of day



Display

Select how you would like the time of day to show on the display when the steam oven is turned off:

- On

The time of day will always appear in the display. To turn the lighting  on and off or use the  touch the relevant sensor.

- Off

The display is turned off to save energy. The steam oven has to be turned on before you can use it. This also applies when using the light  and timer  functions.

- Night Dimming

To save energy, the time is only visible on the display between 5:00 am and 11:00 pm. The rest of the time it is not visible.

Clock format

You can select the clock format for the time of day:

- 24 h

The time of day is shown in a 24 hour clock format.

- 12 h

The time of day is shown in a 12 hour clock format.

Set

Set the hours and the minutes.

If there is an interruption to the power supply, the current time of day will reappear once power has been restored. The time is stored in memory for about 200 hours.

Settings

Date

Set the date.

When the steam oven is turned off, the date will only appear on the display if the Time | Show | On is selected.

Lighting

- On

The interior lighting is turned on during the entire cooking period.

- On for 15 Seconds

The oven lighting turns off 15 seconds after a program starts. Touching  turns it on for another 15 seconds.

Display brightness

The display brightness is represented by a bar with seven segments.



- Select Darker or Brighter to change the brightness of the display.

Acoustic tone information

Melody

At the end of a process, a melody will sound several times in intervals.

The volume of the melody is represented by a bar with seven segments.



Maximum volume is selected when all segments are filled. If none of the segments are filled, the melody is turned off.

- Select Quieter or Louder, to adjust the volume.
- Select On or Off, to turn the melody on or off.

Solo tone

At the end of a process, a continuous tone will sound for period of time.

The pitch of this tone is represented by a segment bar.

- Select Lower or Higher, to change the pitch.

Keypad tone

An audible tone is heard with each touch of a sensor.

The volume of the keypad tone is represented by a bar with seven segments.



Maximum volume is selected when all segments are filled. If none of the segments are filled, the volume is turned off.

- Select **Quieter** or **Louder**, to adjust the volume.
- Select **On** or **Off**, to turn the keypad tone on or off.

Units of measurement

Weight

- g
The weight of food in MasterChef programs is shown in grams.
- lb
The weight of food in MasterChef programs is shown in pounds.
- lb/oz
The weight of food in MasterChef programs is shown in pounds and ounces.

Temperature

- °C
The temperature is displayed in Celsius.
- °F
The temperature is displayed in Fahrenheit.

Settings

Keeping Warm

Please note that delicate food, especially fish, can continue cooking while being kept warm.

– On

The "Keeping Warm" function is activated as standard with the Steam Cooking mode if a minimum temperature of about 175°F / 80°C is used for cooking. If food is not removed from the steam oven at the end of a program, this function will automatically start after approx. 5 minutes. Keeping Warm will appear in the display and the food will be kept warm for approx. 15 minutes at a temperature of 160°F / 70°C. The warming function is canceled when the illuminated sensor button or ↵ is tapped or when the door is opened.

– Off

The "Keeping Warm" function is deactivated.

Steam Reduction

– On

If a temperature of about 175°F / 80°C was used for cooking, the door of the steam oven will automatically open slightly shortly before the end of the cooking duration. This is to prevent a large amount of steam escaping when the door is opened. The door will close again automatically.

– Off

If steam reduction is turned off the Keeping Warm function is also automatically turned off. If steam reduction is turned off a large amount of steam will escape when the door is opened.

Default temperatures

If you often cook with temperatures that differ from the default, it makes sense to change the default temperatures.

After selecting this option, a list of oven modes will appear in the display.

■ Select the desired mode.

The default temperature is displayed along with the available temperature range.

■ Change the default temperature.

■ Confirm with OK.

Safety

System lock

The system lock prevents the appliance being turned on by mistake.

The timer can still be used when the system lock is active.

The system lock will remain activated even after a power failure.

– On

The system lock is now active. If you want to use the steam oven after activation, press and hold the sensor button next to OK for at least 6 seconds.

– Off

The system lock is not active. You can use the steam oven as normal.

Sensor lock

The sensor button lock prevents you from accidentally turning the oven off or changing a cooking program.

– On

The sensor lock is active. Press and hold OK for at least 6 seconds to use the sensors again. The sensor lock is then deactivated for a short period of time.

– Off

The sensor lock is not active. All sensors react to touch as normal.

Water hardness

The steam oven is factory set for Hard water. It must be adjusted to local water hardness to ensure trouble-free operation and to ensure that descaling is carried out at the correct interval. The harder the water, the more often it will need to be descaled.

– Soft

< 8.7 °gr/gal, < 1.5 mmol/l

– Medium

8.7 - 14.6 °gr/gal, 1.5 - 2.5 mmol/l

– Hard

> 14.6 °gr/gal, > 2.5 mmol/l

Settings

Showroom Program

This mode enables the oven to be demonstrated in showrooms without heating up. It should not be set for domestic use.

Demo Mode

If demo mode is activated Demo mode active. The appliance will not heat up **will appear when the steam oven is turned on.**

– On

Press and hold OK for at least 4 seconds to activate demo mode.

– Off

Press and hold OK for at least 4 seconds to deactivate demo mode. The steam oven can then be used as normal.

Factory default

– Settings

Any settings that have been altered will be reset to the factory default setting.

– Favorites

All Favorites will be deleted.

– Default Temperature

Any default temperatures that have been changed will reset to the factory default settings.

Important information on cleaning and care



Risk of injury!

The steam from a steam cleaner could reach electrical components and cause a short circuit.

Do not use a steam cleaner to clean the steam oven.

Unsuitable cleaning agents can discolor and damage the surfaces of the appliance. Only use a solution of liquid dish soap and warm water applied with a soft sponge or cloth.

All surfaces are susceptible to scratching. Scratches on glass surfaces may cause a breakage.

Immediately remove any residues left by cleaning agents.

Do not use cleaning agents or dish-washing liquids containing aliphatic hydrocarbons as these could cause the seals to swell.

Disconnect the appliance from the power supply and allow it to cool down to a safe temperature before cleaning.

- The appliance and accessories should be cleaned and dried thoroughly after each use.
- Leave the appliance door open until the oven interior is completely dry.

If the appliance is not going to be used for a longer period of time, e.g. while on vacation, it should be thoroughly cleaned and dried beforehand to prevent the build-up of odors, etc. Leave the door open afterwards.

Cleaning and care

Appliance front

To better maintain your appliance avoid the following:

To avoid damaging surfaces when cleaning, do not use:

- Cleaners containing soda, ammonia, thinners, or chlorides
- Descaling agents
- Abrasive cleaning agents (e.g., powder or cream cleansers, pumice stones)
- Solvent-based cleaners
- Stainless steel cleaners
- Dishwasher cleaners
- Glass cleaning agents
- Ceramic cooktop cleaners
- Hard, abrasive brushes or sponges (e.g. pot scrubbers or scrub sponges, sponges which have previously been used with abrasive cleaning agents)
- Eraser sponges
- Sharp metal scrapers
- Steel wool
- Stainless steel spiral pads
- Spot cleaners
- Oven sprays

- Clean the front with a solution of warm water and liquid dish soap applied with a clean sponge or cloth. A clean, damp microfiber cloth without cleaning agent can also be used.
- After cleaning dry the front of the appliance with a soft cloth.

Oven interior

- Remove:
 - Condensate using a sponge or absorbent cloth
 - Light, greasy soiling with a sponge and a solution of liquid dish soap and hot water

After prolonged use, the **floor heating element** can become discolored.

- Discoloration of the floor heating element can be removed using the Original Miele ceramic and stainless steel cleaner (see "Optional accessories").
- After cleaning, wipe with clean water to remove any detergent residues.
- Then dry the oven interior and the inside of the door with a cloth.

The **door seal** is designed to last the lifetime of the appliance. Should it for any reason need replacing please contact Miele Service (see the end of these operating instructions).

Automatic door opener

Ensure that the door opener does not become soiled with food residues.

- Wipe away light soiling **immediately** with a clean sponge and a solution of liquid dish soap and warm water.
- After cleaning, wipe with clean water to remove any detergent residues.

Water container

- Remove and empty the water container after each use.
- Remove and empty the water container after each use. Rinse it by hand and then dry it to prevent limescale.

Cleaning and care

Accessories

All accessories are dishwasher safe.

Drip tray, rack and cooking pans

- Wash and dry the drip tray, rack and cooking pans after each use.
- Bluish discoloration from cooking pans and limescale deposits on the filter in the floor of the oven can be easily removed using the Miele ceramic and stainless steel cleaner (see "Optional accessories").
- Rinse cooking pans thoroughly with clean water to remove any detergent residues.

Shelf runners

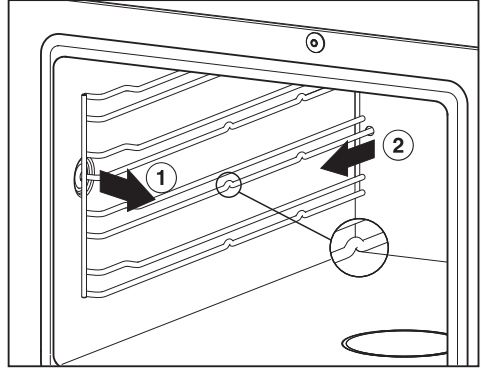

- Pull the side runners out first at the side ①, then at the back ② of the steam oven.
- The side runners can be washed in the dishwasher or by hand with a solution of warm water and liquid dish soap applied with a clean sponge or cloth.
- Push the side runners firmly back in after cleaning. When putting them back in, make sure they are correctly inserted (see illustration).

If the side runners are not correctly inserted there is no anti-tip protection, items could be pulled out of the steam oven inadvertently and the temperature sensor could be damaged when cooking pans are placed in the steam oven.

Descaling

We recommend that you use Miele Descaling Tablets (see "Optional accessories") for descaling the appliance. They have been specifically designed for optimal descaling of Miele products. Other descaling agents, which - in addition to citric acid - may contain other acids and/or other undesirable substances such as chlorides, might damage the product. Also, the desired effect cannot be guaranteed if the descaling solution does not have the required concentration.

Descaling solution is acidic. Do not spill descaling agent onto metal surfaces. This can cause marks to appear. However, should any descaling agent get onto these surfaces, wipe it away immediately.

The steam oven needs to be descaled after a certain number of operating hours. When the steam oven needs to be descaled, a number will appear on the display indicating the number of cooking processes remaining before the appliance locks out. After the last remaining cooking process, the appliance will lock out.

We recommend that you descale the appliance before it locks out.

The water container will need emptying, rinsing and refilling with fresh tap water during descaling.

The Ready at and Start at functions are not available for descaling.

- Turn the steam oven off and select **Descale**.

A message will appear on the display:

- Fill the water container with cold water to the marking  and add 2 Miele descaling tablets.
- Push the water container into the appliance until it engages.
- Confirm with **OK**.

The descaling process will now begin, and the time left will count down on the display.

It is only possible to cancel the descaling process during the first 6 minutes. Do not turn the appliance off during the descaling process. If it is turned off before the end of the process, the whole process will have to be started from the beginning again.

During the course of the descaling process, the water container needs to be rinsed and filled with fresh water.

- Follow the instructions on the display.

When the descaling process has finished, a message will appear on the display.

Cleaning and care

After descaling

- Turn the steam oven off.
- Remove, empty and dry the water container.
- Dry the oven compartment.
- Leave the appliance door open until the oven interior is completely dry.

Door

Removal

- Prepare a suitable underlay for the door, such as a soft cloth.

Before removing the door, the locking clamps on both hinges have to be released.

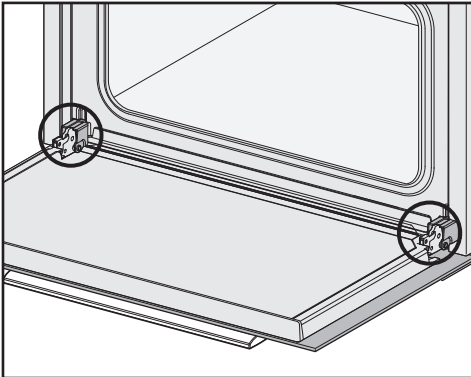

- Open the door fully.

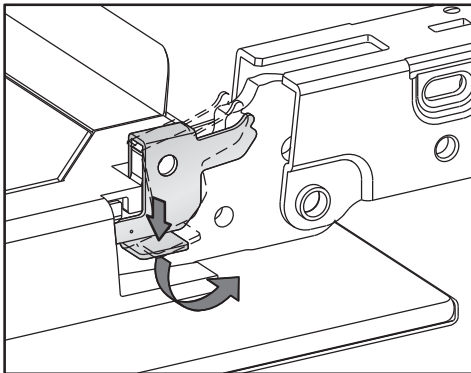

- Release the locking clamps on the hinges by pushing them down. Turn them as far as they will go in an angled position.

! Danger of injury due to the hinge guides!

The hinge guides retract to the steam oven.

Never attempt to pull the door off the hinge guides from a horizontal position.

- Close the door until it rests partially open.

Risk of damage to the door!

The door handle could break off and the glass could be damaged.

The door should be gripped firmly at the sides and not at the handle when being removed.

Make sure that the door is not tilted during removal.

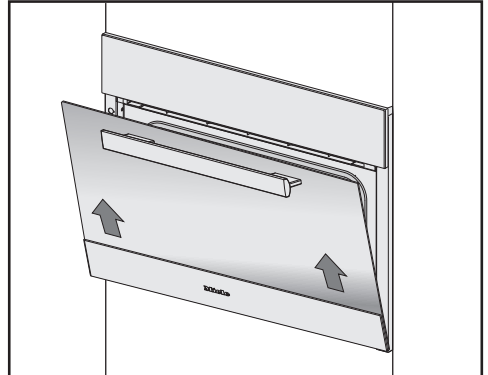

- Hold the door on either side and pull diagonally upwards from the hinge guides.
- Lay the appliance on the previously prepared underlay.

Cleaning and care

Refitting the door

Risk of damage to the door!
Make sure that the door does not cant when being refitted.

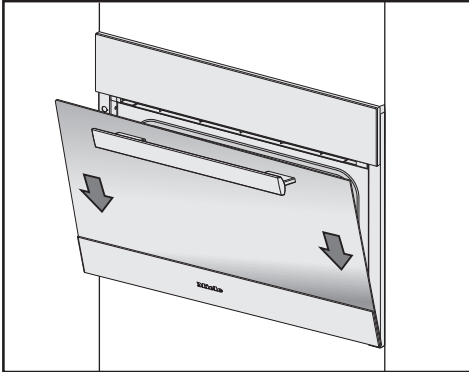

- Slide the door onto the hinge guides again.

Risk of damage to the door!
If the locking clamps are not locked, the door can easily become detached from the hinge guides and be damaged.
You must make sure that the locking clamps are locked again.

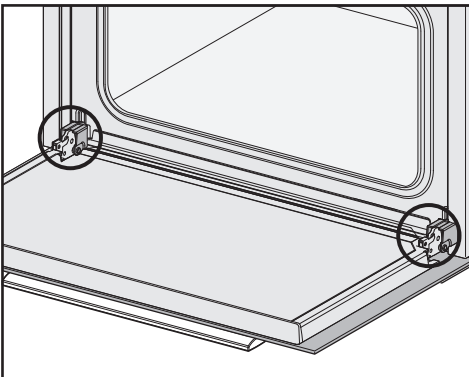

- Open the door fully.

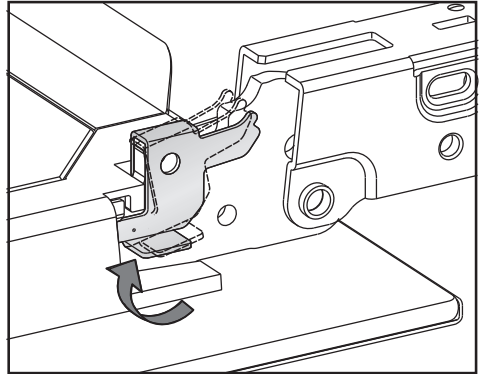

- To relock the locking clamps, turn them back up to the horizontal position as far as they will go.

Frequently asked questions

The following faults can be corrected without contacting the Miele Service Department.

If in doubt, please contact Miele.

 Risk of injury! Improperly performed installation, maintenance or repair work can pose a serious danger to users of the appliance. Installation, maintenance and repairs may only be carried out by Miele authorized technicians.
Do not attempt to open the housing.

Problem	Possible cause and solution
You cannot turn the appliance on.	<p>The circuit breaker has tripped.</p> <ul style="list-style-type: none"> ■ Reset the circuit breaker (see data plate for the correct fuse rating). <p>There may be a technical fault.</p> <ul style="list-style-type: none"> ■ Disconnect the appliance from the power supply for approx. 1 minute: <ul style="list-style-type: none"> – tripping the relevant circuit breaker or screwing the fuse out completely, or – tripping the ground fault circuit interrupter (GFCI). ■ If the steam oven still will not turn on, contact a qualified electrician or Miele Service.
The steam oven does not heat up.	<p>Demonstration mode is active</p> <ul style="list-style-type: none"> ■ Deactivate Demo mode (see "Settings – Show-room Program").
The fan can still be heard after the appliance has been turned off.	<p>The fan is still running. The appliance is fitted with a fan which removes steam from the oven. The fan will continue to run for a while after the appliance has been switched off. It will turn itself off automatically after a while.</p>
A humming sound can be heard after switching on the appliance, during operation and after turning off the appliance.	<p>This is not a fault. It is made by water being pumped through the system.</p>

Frequently asked questions

Problem	Possible cause and solution
After moving house the appliance no longer turns from the heating-up phase to the cooking phase.	<p>The boiling temperature of the water has changed as the altitude of the new location for the appliance differs from the old one by at least 984' / 300 m.</p> <ul style="list-style-type: none"> ■ To adjust the boiling temperature, you need to descale the appliance (see "Cleaning and care - Descaling").
During operation, an unusually large amount of steam escapes or steam escapes from parts of the steam oven where it does not usually.	<p>The door is not properly closed.</p> <ul style="list-style-type: none"> ■ Close the door.
	<p>The door seal is not correctly fitted.</p> <ul style="list-style-type: none"> ■ If necessary, press it in all the way round the door to make sure it is fitted evenly.
	<p>The door seal is damaged, e.g. cracked.</p> <ul style="list-style-type: none"> ■ Contact Miele Service.
A whistling sound is heard when the appliance is turned on again.	<p>When the door is closed, the pressure has to equalize, which can cause a whistling sound. This is not a fault.</p>
The Start at and Ready at functions have not worked.	<p>The oven cavity temperature is too high, e.g. after a program has finished.</p> <ul style="list-style-type: none"> ■ Leave the door open to cool down the oven cavity.
	<p>These functions are not generally available with Menu Cooking and Descale.</p>
The oven lighting does not come on.	<p>The lamp needs to be replaced.</p> <ul style="list-style-type: none"> ■ Contact Miele Service to have the lamp replaced.
F 44	<p>Communication fault</p> <ul style="list-style-type: none"> ■ Turn the steam oven off and then back on again after a few minutes. ■ If the same message appears again, contact Miele Service.
F and other fault codes	<p>Technical fault</p> <ul style="list-style-type: none"> ■ Turn the appliance off and contact Miele.

Miele offers a range of useful accessories, as well as cleaning and conditioning products for your appliance.

Depending on country, these can be ordered online from Miele.



You can also obtain these products from Miele Service (see end of this booklet for contact details) or your Miele dealer.

Cooking pan

There is a wide range of perforated and solid cooking pans available in different sizes:

DGGL 1

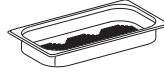

Perforated cooking pan
12 3/4" x 7" x 1 1/2" (WxDxH)
325 x 175 x 40 mm (WxDxH)

DGG 2

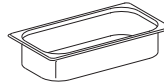

Solid cooking pan
12 3/4" x 7" x 2 1/2" (WxDxH)
325 x 175 x 65 mm (WxDxH)

DGG 3

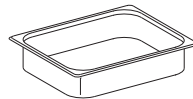

Solid cooking pan
12 3/4" x 10 1/2" x 2 1/2" (WxDxH)
325 x 265 x 65 mm (WxDxH)

Optional accessories

DGGL 4

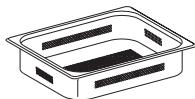

Perforated cooking pan
12 3/4" x 10 1/2" x 2 1/2" (WxDxH)
325 x 265 x 65 mm (WxDxH)

DGGL 5

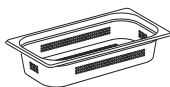

Perforated cooking pan
12 3/4" x 7" x 2 1/2" (WxDxH)
325 x 175 x 65 mm (WxDxH)

DGGL 6

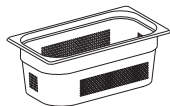

Perforated cooking pan
12 3/4" x 7" x 4" (WxDxH)
325 x 175 x 100 mm (WxDxH)

DGG 7

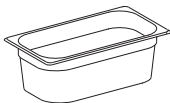

Solid cooking pan
12 3/4" x 7" x 4" (WxDxH)
325 x 175 x 100 mm (WxDxH)

DGGL 8

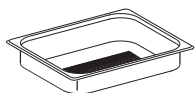

Perforated cooking pan
12 3/4" x 10 1/2" x 1 1/2" (WxDxH)
325 x 265 x 40 mm (WxDxH)

DGGL 13

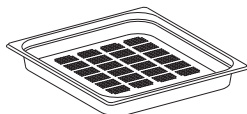

Perforated cooking pan
12 3/4" x 14" x 1 1/2" (WxDxH)
325 x 350 x 40 mm (WxDxH)

Lid for cooking pans

DGD 1/3



Lid for 12 3/4" x 7" (325 x 175 mm)
cooking pans

DGD 1/2



Lid for 12 3/4" x 10 1/2" (325 x 265 mm)
cooking pans

Cleaning and care products

Descaling tablets (Qty 6)



For descaling the appliance

Ceramic and stainless steel cleaner 250 ml/8 oz.



Removes discoloration from cooking pans.

Microfiber cloth

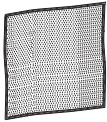

Removes finger marks and light soiling.

Additional accessories

DGG 21



Drip tray for collecting excess moisture, can also be used as a cooking pan.
12 3/4" x 17" x 1 1/2" (WxDxH) 325 x 430 x 40 mm (WxDxH)

Wire oven rack

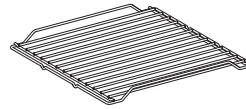

For placing your own cooking pans

Multi casserole dish

Die-cast aluminum casserole dish with non-stick surface and stainless steel lid. Also suitable for use on an extended zone of induction cooktops and in all Miele ovens.

Not suitable for use on gas cook-tops.

KMB 5000-S

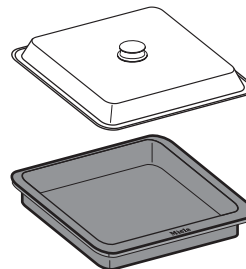

12 3/4" x 10 1/4" x 2 3/8" (WxDxH)
325 x 260 x 60 mm (WxDxH)

IMPORTANT SAFETY INSTRUCTIONS - INSTALLATION

 Incorrect installation can result in personal injury and damage to property.

- ▶ Before connecting the appliance to the mains supply, ensure that the connection data on the data plate (voltage and frequency) match the mains electricity supply. This data must correspond in order to avoid the risk of damage to the appliance. Consult a qualified electrician if in any doubt.
- ▶ Do not use an extension cord to connect this appliance to electricity. Extension cords do not guarantee the required safety of the appliance.
- ▶ The electrical outlet should be easily accessible after the appliance has been installed.
- ▶ The appliance must be positioned so that you can see the contents of a cooking pan placed on the top level. Otherwise you may risk scalding or burning yourself with hot water and food when taking containers out of the oven.

All dimensions in this instruction booklet are given in mm and inches.

Detailed dimensions of oven front

PureLine front

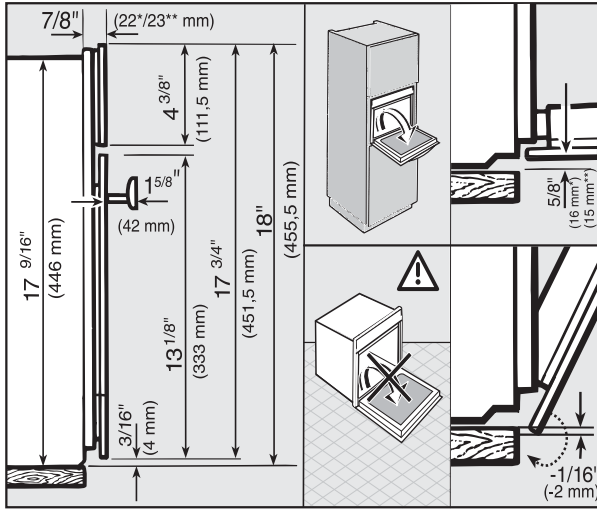

ContourLine front

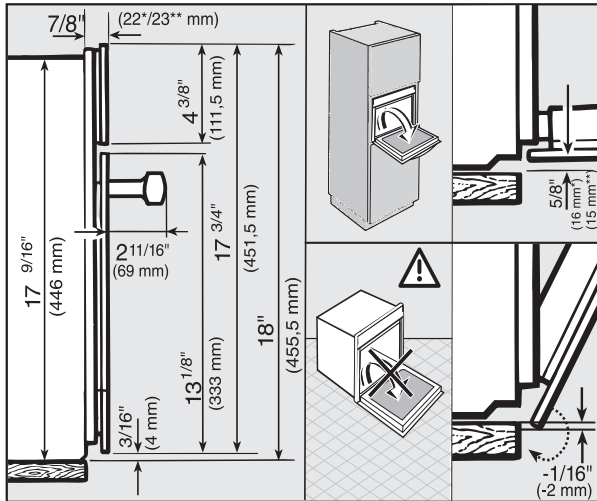

* Glass front / ** Metal front

Installation dimensions

Installation into a tall cabinet

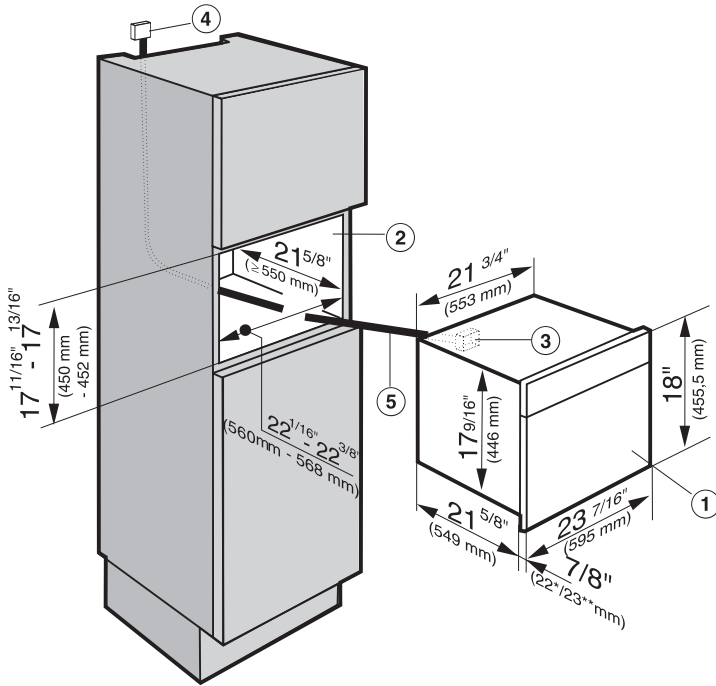

- ① Steam oven
- ② Niche
- ③ Pass-through for the power cord
- ④ Recommended position for electrical outlet
- ⑤ Power cord

* Glass front / ** Metal front

Undercounter installation

When building the appliance into a base unit underneath a cooktop, please also observe the installation instructions for the cooker and its respective installation depth (see the installation instructions for the cooktop).

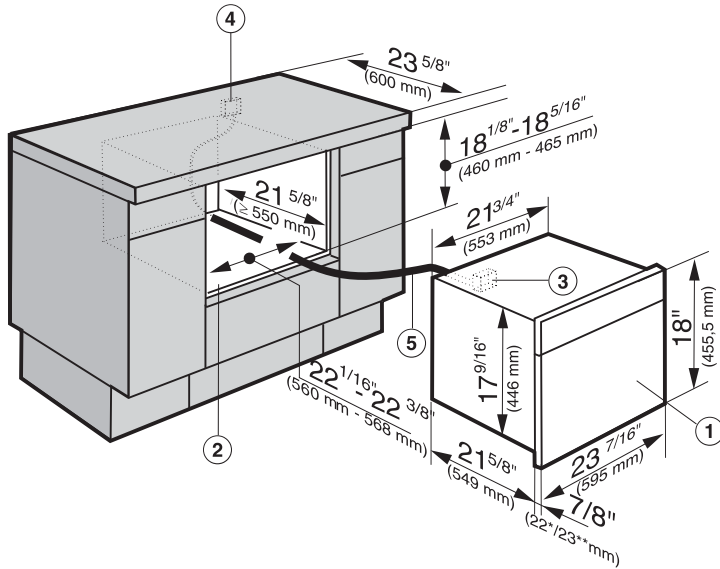

- ① Steam oven
- ② Niche
- ③ Pass-through for the power cord
- ④ Recommended position for electrical outlet
- ⑤ Power cord

* Glass front / ** Metal front

Installation dimensions

Installation in combination with an oven

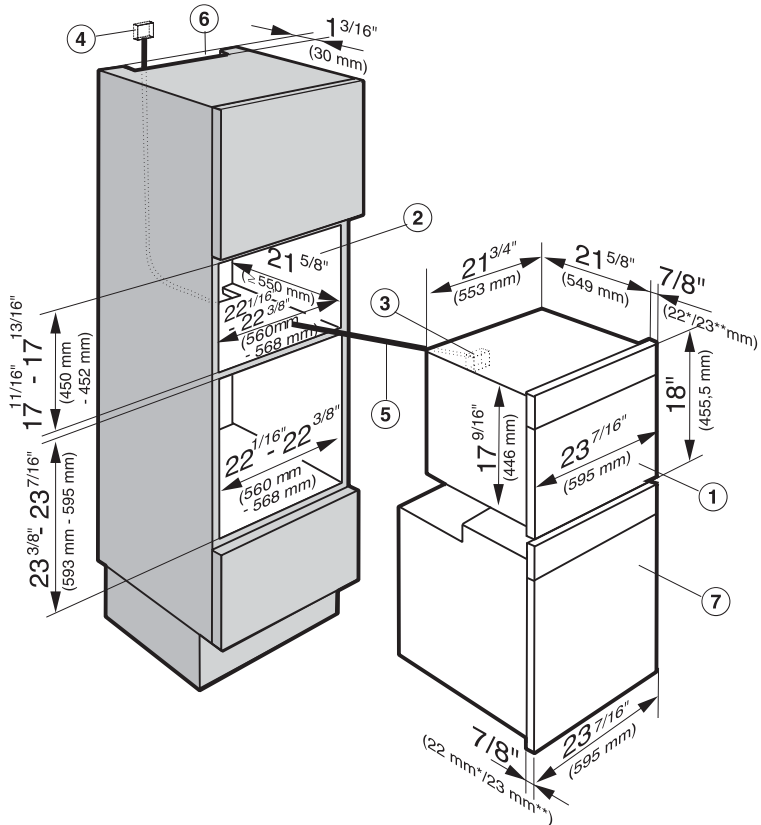

- ① Steam oven
- ② Niche
- ③ Pass-through for the power cord
- ④ Recommended position for electrical outlet
- ⑤ Power cord
- ⑥ Cut-out for ventilation (only necessary when installing above a Self Cleaning oven)
- ⑦ Oven

* Glass front / ** Metal front

Installing the steam oven

A malfunction can occur if the appliance is not correctly aligned.

For correct functioning of the steam generator please make sure that the appliance is horizontally level. The maximum deviation should not exceed 2°.

- Push the appliance into position in the niche and align it. Make sure that the power cord and water intake and drain hoses do not get pinched or damaged when doing so.

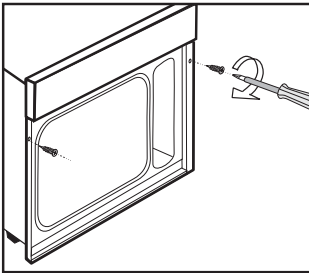

- Secure the appliance left and right using the screws supplied (1/8" x 1" / 3.5 mm x 25 mm) to the sides of the unit, as illustrated.
- Check the appliance for correct function in accordance with the operating instructions.

Electrical connection

ATTENTION:

Before installation or servicing, disconnect the power supply by either removing the fuse, manually "tripping" the circuit breaker or unplugging the appliance. Pull the plug not the cord.

Installation work and repairs should only be performed by a qualified technician in accordance with all applicable codes and standards. Repairs and service by unqualified persons could be dangerous and the manufacturer will not be held responsible. Installation, repair, and maintenance work should only be performed by a Miele-authorized service technician. Work by unqualified persons can cause considerable danger to users. Miele cannot be held liable for any damage arising as a result of such work.

Before connecting the appliance to the power supply, make sure that the voltage and frequency listed on the rating label correspond with the household electrical supply. This data must correspond to prevent appliance damage. Consult an electrician if in doubt.

For safety reasons, the steam oven may only be used when it has been fully installed.

Installer:

- Please leave these instructions with the customer.

Connection

- Ensure that the connection data on the data plate (voltage, frequency, and fuse rating) match those of your electrical supply.

Power Supply

This appliance is equipped with a 5 ft (1.5 m) long power cord with a NEMA 6-20P three-prong grounding plug ready for connection.

208/240 V / 20 A / 60 Hz

Make sure that the connecting socket is accessible after the installation of the steam oven.

Disposal of the packing material

The cardboard box and packing materials protect the appliance during shipping. They have been designed to be biodegradable and recyclable.

Ensure that any plastic wrappings, bags, etc. are disposed of safely and kept out of the reach of children. Danger of suffocation!

Disposal of your old appliance

Old electrical and electronic appliances often still contain valuable materials. However, they also contain harmful substances that were essential for the proper functioning and safe use of the equipment. Handling these materials improperly or disposing of them in your household waste can be harmful to your health and the environment. Therefore, please do not dispose of your old appliance with regular household waste.

Old appliances may contain materials that can be recycled. Please contact your local recycling authority about the possibility of recycling these materials.

Please be sure that your old appliance does not pose a danger to children while being stored for disposal.

Technical service, data plate, warranty

After sales service

In the event of a fault which you cannot easily correct yourself, please contact:

- your Miele dealer, or
- the Miele Technical Service Department.

See back cover for contact details.

Please quote the model and serial number of your appliance when contacting Miele.

Data plate

Adhere the extra data plate supplied with the appliance here. Ensure that the model number is the same as the one on the back of these operating instructions.

Warranty

For further information, please refer to your warranty booklet.

This service is available in USA only.

MieleCare, our Extended Service Contract program, gives you the assurance of knowing that your appliance investment is covered by 5 years of worry free ownership.

MieleCare is the only Extended Service Contract in the industry that guarantees repairs by a Miele Authorized Service Provider using genuine Miele parts. Only genuine Miele parts installed by factory trained professionals can guarantee the safety, reliability, and longevity of your Miele appliance.

Please note that unless expressly approved in writing by Miele's Service department, Extended Service Contracts offered by other providers for Miele products will not be recognized by Miele. Our goal is to prevent unauthorized (and untrained) service personnel from working on your Miele products, possibly doing further damage to them, you and/or your home.

To learn more about **MieleCare** Extended Service Contracts, please contact your appliance dealer or visit us online at:

www.mieleusa.com/mielecare

Please have the model and serial number of your appliance available before contacting Technical Service.

Miele

U.S.A.

Miele, Inc.

National Headquarters

9 Independence Way
Princeton, NJ 08540

Phone: 800-843-7231
609-419-9898

Fax: 609-419-4298

www.mieleusa.com

Technical Service & Support

Nationwide

Phone: 800-999-1360

Fax: 888-586-8056

TechnicalService@mieleusa.com

Canada

Importer

Miele Limited

Headquarters and Miele Centre

161 Four Valley Drive
Vaughan, ON L4K 4V8

www.miele.ca

Customer Care Centre

Phone: 800-565-6435

905-532-2272

customercare@miele.ca

Germany

Manufacturer

Miele & Cie. KG
Carl-Miele-Straße 29
33332 Gütersloh



www.miele-shop.com

DG 6500 / DG 6600



en-US, CA

M.-Nr. 09 800 830 / 06