

Diagrams

◀24"▶

Fully Integrated Wine Unit

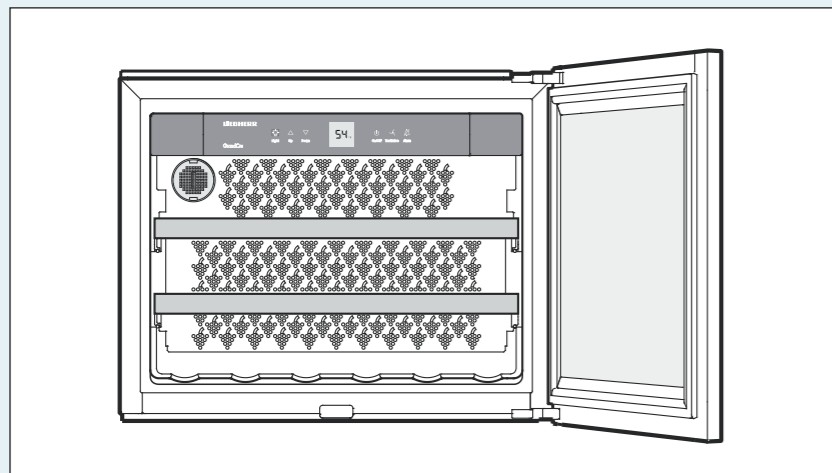

Energy Supply	115V / 60Hz / 1A
Climate Rating	SN
Door hinges	right/reversible
Door	glass door with stainless steel frame

- Touch electronic control system
- Telescopic wine shelves
- Activated charcoal filter
- LED-light

Appliance Dimensions

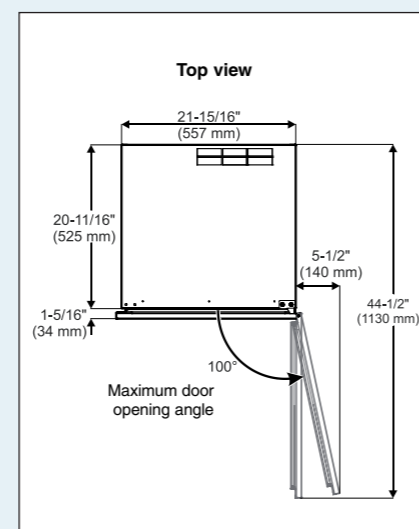
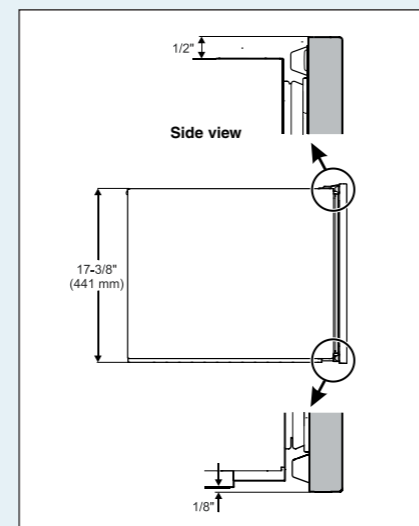

Cabinet Dimensions - Flush Face Installation

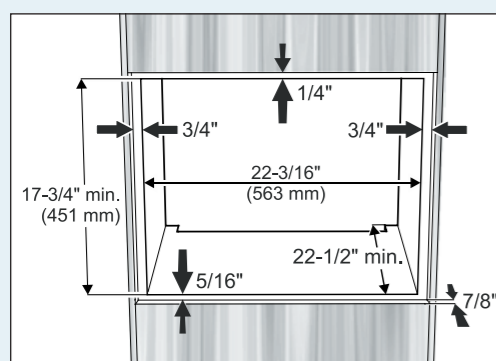

Cabinet dimensions for installations into a cabinet wall. Front of appliance door is flush with the cabinet front surface. Front opening results in a 3/16" gap between appliance door and outer recess.

IMPORTANT: The appliance must be centered in the recess to avoid collision of the right door edge with the cabinet when the door is opened.

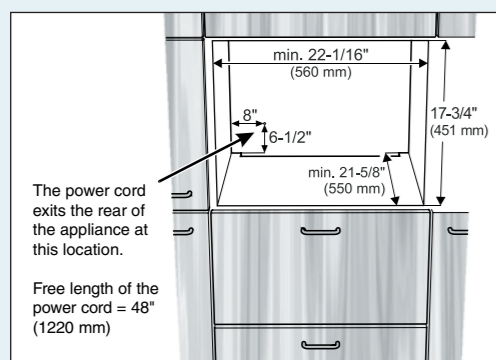

IMPORTANT: The electrical outlet must not be situated behind the appliance and must be easily accessible.

Appliance Venting

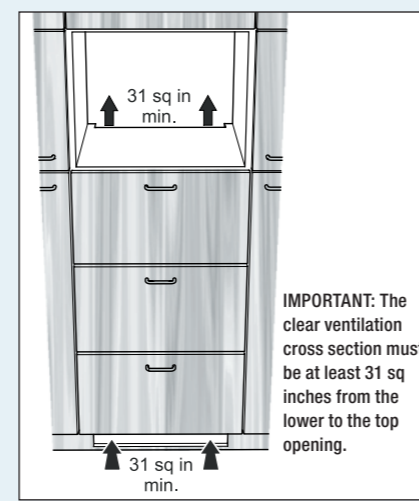

IMPORTANT: The clear ventilation cross section must be at least 31 sq inches from the lower to the top opening.



Liebherr HWS 1800 Wine Cabinet



LIEBHERR

Quality, Design and Innovation

Wine Cabinet

HWS 1800, the fully integrated wine unit that holds 18 Bordeaux bottles in an ideal storage environment. The innovative styling allows the unit to sit flush with cabinetry and its recessed handle maintains crisp, simple lines that incorporate beautifully into your custom kitchen design. Take advantage of the units design flexibility and place this sleek, modular wine cabinet anywhere in your home and proudly display your fine wine collection at eye level. The temperature is continuously adjustable from 41° to 68°F (5° to 20°C) and the LED ceiling light is dimmable to cast a cool glow across the room. The insulated glass door with UV protection and the activated charcoal filter protect the wine from busy kitchen influences such as light and odor. For 30" wide cabinets Liebherr offers a special trim kit with stainless steel panels.



◀24"▶

Wine Cabinet

Capacity

Total capacity cu.ft. (l)

Max. No. of Bordeaux btls 0.75 l

Shipping weight lbs. (kg)

Climate rating

Sound rating dB(A)

Door hinges

Outside dimensions

in inches (cm) H/W/D

Cut out dimensions

in inches (cm) H /W/D

Energy supply

Voltage V/Hz

HWS 1800 GrandCru

Wine

LED

Telescopic
Rails

1.7 (47)

18

72.8 (33)

SN

36

right, reversible

17 3/8" / 21 15/16" / min. 22" (44 / 55.7 / min. 55.8)

17 3/4" / 22 1/16" / min. 21 5/8" (45 / 56 / 55)

115/60

* Energy Cost will depend on utility rates and use. Estimated energy cost based on a national average electricity cost of 12 cents per kWh.

** Noise output – according to EN 60704-3

Features

◀24"▶



German Engineering: Our superior products offer premium quality, cutting edge design and innovative features that fit your busy lifestyle. Exclusive components and materials, along with the latest production processes, ensure energy efficiency and performance for years to come.



Beech wood Shelving: Solid beech wood shelves on telescopic rails for easy wine access.



Alarm System: Liebherr Wine units are equipped with a trustworthy alarm system to alert the homeowner if the door has been left open or the temperature has been compromised.



LED

LED Lighting: The energy efficient LED ceiling light not only emits virtually no heat, but it is dimmable to cast a cool glow to give a pleasing ambient light inside the appliance as well as the room.



FreshAir Activated Charcoal Filter: Liebherr wine cabinets are fitted with easy-to-replace FreshAir activated charcoal filters to ensure clean air. Odors are filtered out and the quality of the wine is protected.



Compressors: Specially developed compressors installed in the wine cabinets from Liebherr ensure that the wines are stored in a particularly low vibration environment.



Electronic
Control

Electronic LCD display: Intuitive navigation of touch electronic control system enables tailored storage options. The digital temperature display can be viewed via the UV tinted glass door.



UV Protection: In order to minimize the exposure of light which can damage the maturity of a wine, Liebherr wine cabinets are fitted with special UV-resistant insulated glass; simultaneously protecting and presenting your wine.