

LIEBHERR

Use and Care Manual with Installation Instructions

for built in wine cooler

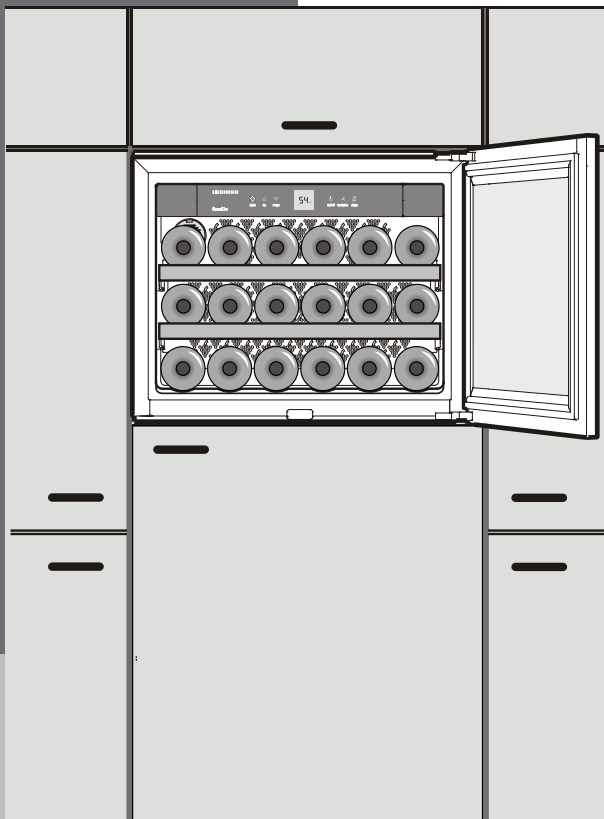

HWS 1800
7082 635-00

TABLE OF CONTENTS

Keep these operating instructions in a safe place and pass them on to the next owner, where applicable.

Contents	Page
Safety	3
Disposal of Old Appliance.....	3
Electrical Safety.....	3
Important Safety Information.....	4
Safety Regulations	4
Safety Instructions and Warnings.....	5
Disposal of Carton	5
Features	6
Description of Appliance and Equipment	6
Fitting Dimensions.....	6
Installation	7
Reversing Door Hinges.....	7
Installing in a Kitchen Unit.....	7
Operation.....	8
Operating and Control Elements	8
Turning the Appliance ON and OFF	8
Setting the Temperature	8
Fan Switch.....	9
Audible Warning Signal	9
Interior Light	9
Setup Mode.....	10-11
Wine Cooler Compartment.....	12
Equipment	12
Storing Wine.....	12
Defrosting/Cleaning	13
Defrosting	13
Cleaning	13
Troubleshooting.....	14
Customer Service.....	14
Appliance Information	14
Warranty.....	15

IMPORTANT

All types and models are subject to continuous improvement. The manufacturer reserves the right to make modifications in the shape, equipment and technology.

Please read and follow these instructions

These instructions contain Warning and Caution statements. This information is important for safe and efficient installation and operation.

Always read and follow all Warning and Caution statements!

DANGER

Danger indicates a hazard which will cause serious injury or death if precautions are not followed.

WARNING

Warning indicates a potentially hazardous situation which, if not avoided, could result in death or serious injury.

CAUTION

Caution indicates a potentially hazardous situation which, if not avoided, may result in minor or moderate injury.

IMPORTANT

This highlights information that is especially relevant to a problem-free installation and operation.

Make sure incoming voltage is the same as the appliance rating. To reduce the risk of fire, electric shock, or personal injury, installation work and electrical wiring must be done by a qualified electrician in accordance with all applicable codes and standards, including fire-rated construction.

California Proposition 65

- This product contains chemicals known to the state of California to cause cancer or reproductive harm.
- This product can expose you to chemicals including Diisononyl Phthalate (DINP) which is known to the State of California to cause cancer. For more information go to www.P65Warnings.ca.gov.
- This product can expose you to chemicals including Di-isodecyl Phthalate (DIDP) which is known to the State of California to cause birth defects or other reproductive harm. For more information go to www.P65Warnings.ca.gov.

Disposal of Old Appliance

DANGER

Risk of child entrapment. Before you discard your old refrigerator or freezer:

- Be sure to follow your local requirements for disposal of appliances. Discarded appliances can be dangerous.
- Remove the doors.
- Leave the shelves in place so that children may not easily climb inside.
- Cut off the power cable from the discarded appliance. Discard separately from the appliance.

Following these instructions reduces the possibility of causing personal injury, especially to children playing.

Contact the trash collection agency in your area for additional information.

Electrical Safety

Connect this appliance to a 110-120 VAC, 15 amp circuit that is controlled by a circuit breaker or fuse. This appliance should have its own separate grounded circuit. Do not use an extension cord.

The power cord is equipped with a three-prong (grounding) plug for your protection against possible shock hazards. To maintain this protection:

- Do not modify the plug by removing the round grounding prong.
- Do not use a two-prong adapter. Where a two-prong wall receptacle is encountered, contact a qualified electrician and have it replaced with a three-prong receptacle in accordance with all local codes and ordinances.
- Do not use a power cord that is frayed or damaged.

SAFETY

Important Safety Information

Follow the cautions and safety warnings throughout this instruction manual including the following:

- To prevent injury to you or damage to the unit, the appliance should be unpacked and set up by two people.
- If the appliance is damaged on delivery, contact the supplier immediately before connecting to the power source.
- To guarantee safe operation, ensure that appliance is set up and connected as described in these operating instructions.
- Disconnect the appliance from the power source if a fault occurs. Pull out the plug, turn off or disable the power source.
- When disconnecting the appliance, use the plug. Do not pull on the cord.
- Any repairs and work on the appliance should only be performed by the customer service department. Unauthorized work may be dangerous to the user. Changing the power source cable should only be done by the customer service department.
- Do not store explosives or sprays using combustible propellants such as butane, propane, pentane, etc. in the appliance. Electrical components might cause leaking gas to ignite. You may identify such sprays by the printed contents or a flame symbol.
- Do not use electrical appliances inside the appliance.
- To prevent possible injury due to an electrical shock, be sure to disconnect the power cord or turn off the circuit breaker before cleaning the appliance.
- To avoid injury or damage to the appliance, do not use steam cleaning equipment to clean the appliance.
- Do not operate the wine cooler in the presence of explosive fumes.
- In the event of a power outage, minimize opening the door.
- To protect the wine cooler from possible damage, allow the appliance to stand 1/2 to 1 hour in place before turning the electricity on. This allows the refrigerant and system lubrication to reach equilibrium.

Safety Regulations

The appliance is designed to cool and store wine and beverages. It is designed as a household appliance.

The appliance is set to operate within specific ambient temperature limits according to its climate rating. These temperature limits should not be exceeded. The correct climate rating for your appliance is indicated on the model plate.

This is explained as follows:

Climate Rating	Set for Ambient Temperatures of
SN	50°F to 90°F (10°C to 32°C)
N	61°F to 90°F (16°C to 32°C)
ST	61°F to 100°F (16°C to 38°C)
SN-ST	50°F to 100°F (10°C to 38°C)
SN-T	50°F to 109°F (10°C to 43°C)
T	61°F to 109°F (16°C to 43°C)

- The refrigerant circuit has been tested for leaks.
- The appliance complies with current safety regulations UL250 and CSA C22.2 #63.

We recommend cleaning the appliance before turning it ON for the first time. See **Cleaning**. Turn ON the appliance several hours before loading it.



WARNING

Do not allow children to play with the appliance. Children must not climb, sit or stand on the racks or door. Failure to follow these instructions may result in death or serious injury.

Safety Instructions and Warnings

Avoid placing the appliance in direct sunlight or near the stove, range top, radiators and similar heat sources. Do not place microwave ovens, toaster ovens or other heat-emitting appliances on top of this unit.

Keep the appliance out of the weather. The ventilation grilles should not be obstructed. Always ensure there is good ventilation all around the appliance.

As soon as you uncrate the unit:

- Examine the unit and packaging for shipping damage. Contact the carrier immediately if you suspect there is any damage.
- Note the type (model number), service number, serial number, date of purchase and where purchased on the spaces provided in the back of this manual.

Disposal of Carton

The packaging is designed to protect the appliance and individual components during moving and is made of recyclable materials.

- Corrugated board/cardboard
- Molded polystyrene (foamed, CFC-free polystyrene)
- Polythene bags and sheets
- Polypropylene straps

WARNING

Keep packaging materials away from children. Polythene sheets and bags can cause suffocation!

- Please take the packaging material to your local recycling facility.

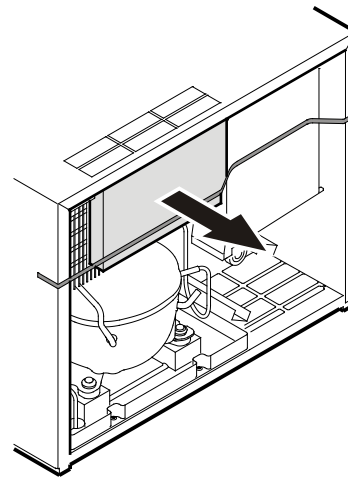

IMPORTANT!

Remove all transportation safety components.

FEATURES

Description of Appliance and Equipment - Figure 1

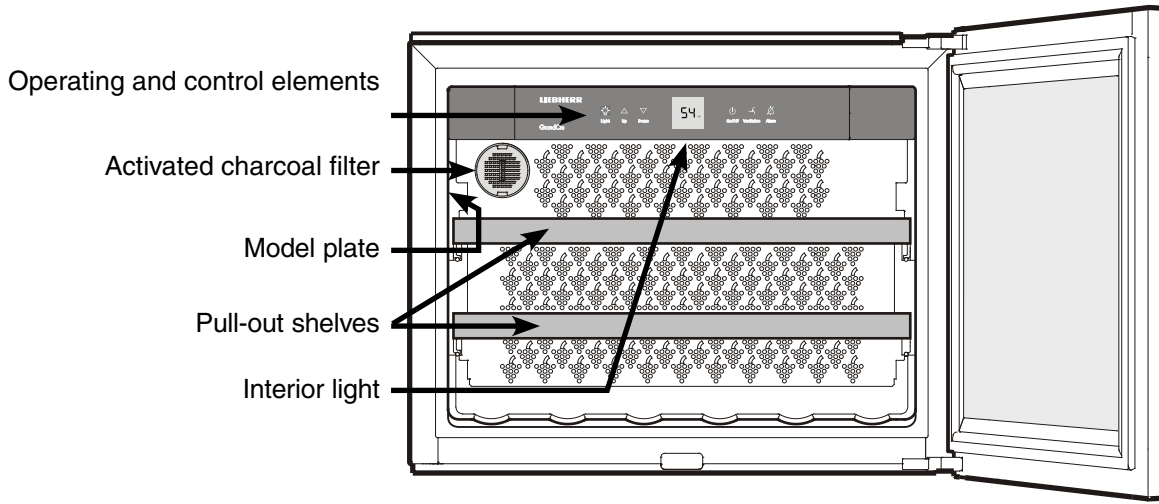

Figure 1

Fitting Dimensions - Figure 2

The area of ventilation above the unit should be at least 31 square inches (200 cm²).

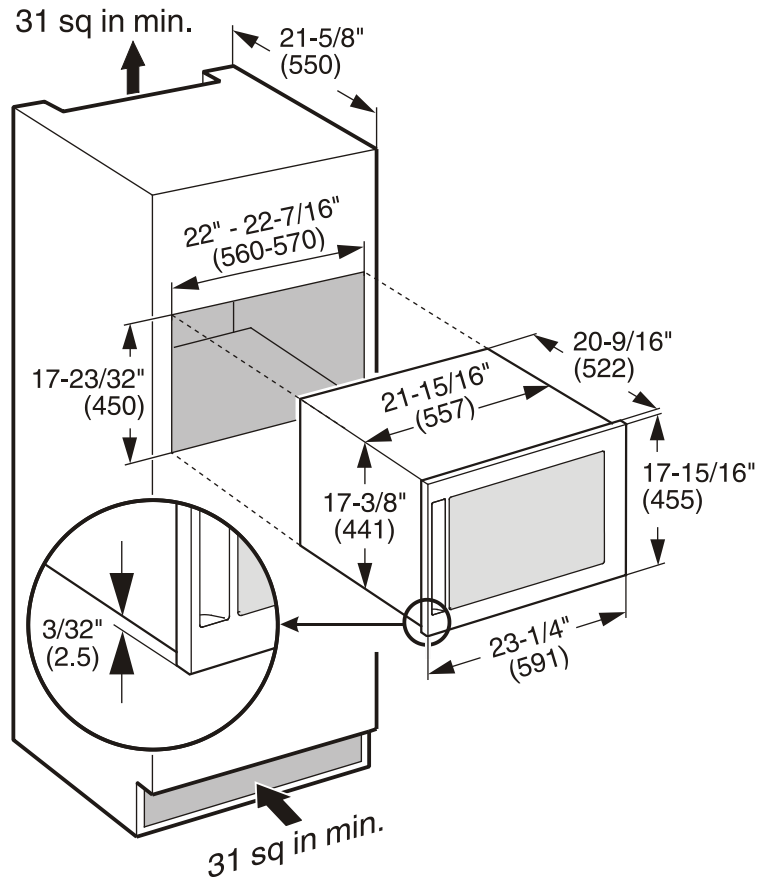

Figure 2

INSTALLATION

Reversing Door Hinges - Figure 3-5

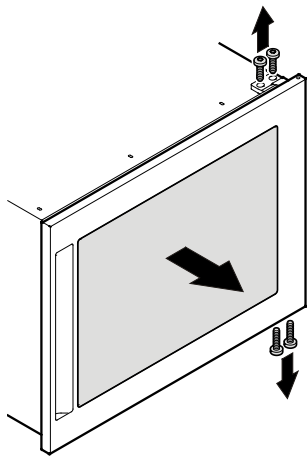

Figure 3

1. Remove the door.

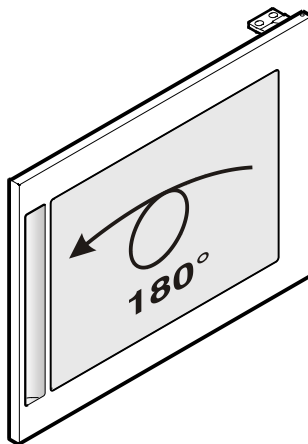

Figure 4

2. Rotate door by 180°.

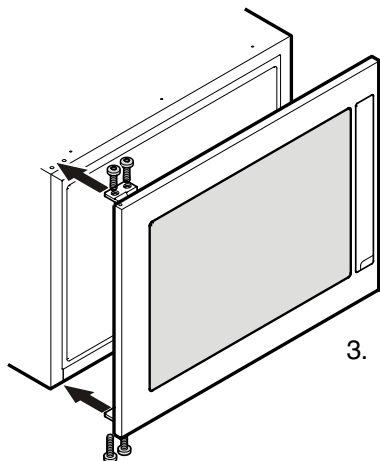

Figure 5

3. Reattach the door.

Installing in a Kitchen Unit -

Figure 6-9

1. Secure the stop bracket in the recess with screws.
2. Connect the appliance to the electrical outlet.

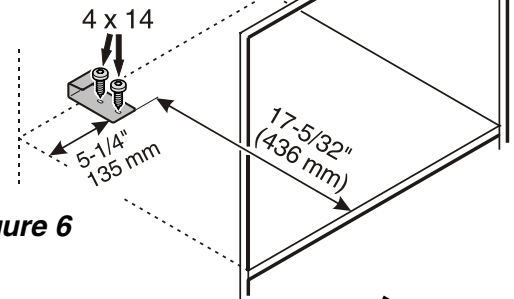

Figure 6

3. Before installing in a kitchen unit, screw the attachment plate provided onto the appliance with screws M4 x 8.

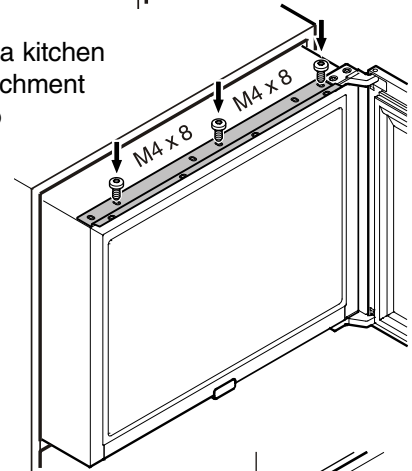
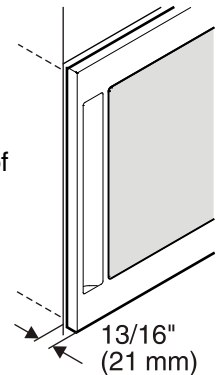

Figure 7

4. Slide the appliance into the recess leaving a 13/16\" data-bbox="503 590 795 651"/>

Figure 8



5. Then secure the appliance with 3.5 x 17 chipboard screws through the top bracket.

Figure 9

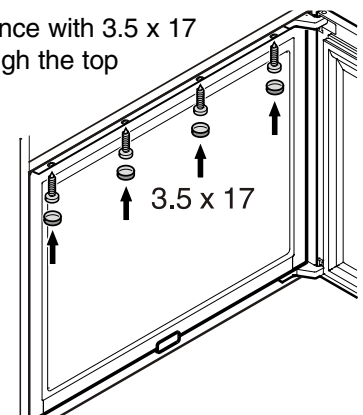

OPERATION

Operating and Control Elements

- Figure 10

The electronic control panel has the “**Touch capacitance technology**”. Any function can be activated by a fingertip on the symbol of the operating icons.

The exact contact point is between the Symbol and its label .

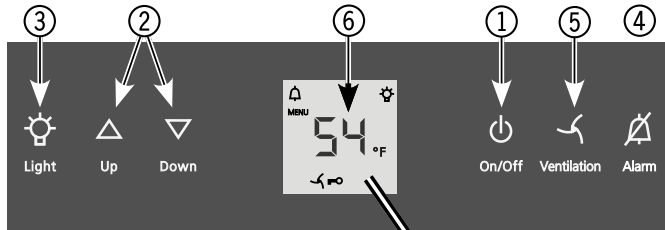

Figure 10

- ① Appliance ON/OFF
- ② Temperature setting buttons
- ③ Interior light ON/OFF
- ④ Mute alarm
- ⑤ Fan ON/OFF
- ⑥ Temperature display
- ⑦ Interior light ON symbol
- ⑧ Alarm symbol
- ⑨ Child lock activated symbol
- ⑩ Fan ON symbol



Turning the Appliance ON and OFF - Figure 11

Clean the appliance before turning it on for the first time. See **Cleaning**. Connect the appliance to the dedicated outlet - the appliance is turned on.

To turn the appliance on: Press the **On/Off** button so the temperature display lights up.

To turn the appliance off: Press the **On/Off** button for approx. 3 seconds so that the temperature display goes out.

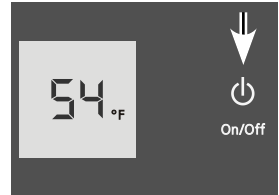

Figure 11

Setting the Temperature - Figure 12

To reduce the temperature: Press the **Down** button.

To increase the temperature: Press the **Up** button.

- While you are entering the temperature, the set temperature will flash on the display.
- You can change the settings in increments of 1°F briefly pressing the button again.
- The electronic controls will switch over automatically about 5 seconds after the last time you pressed the button, and the actual temperature will be displayed.

The temperature can be set at between 41°F and 68°F.

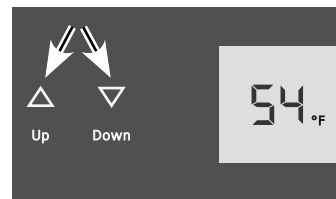

Figure 12

Fan Switch - Figure 13

Switching on the fan improves the climate inside the appliance approaching that of a wine cellar. Corks are prevented from drying out due to an increased level of humidity.

Switching on: Press the **Ventilation** button. The  symbol will light up.

Switching off: Press the **Ventilation** button again. The  symbol will go out.

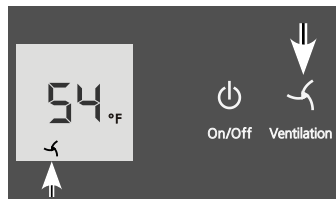



Figure 13

Audible Warning Signal - Figure 14

The audible warning signal helps to protect your wines against excessive temperatures.

It sounds when the door has been left open for longer than 180 seconds.

It sounds when the interior gets too warm or too cold. The temperature display will also flash. The  symbol lights up.

The audible warning device is switched off by pressing the **Alarm** button.

The temperature display will continue to flash until the cause of the alarm has been rectified.

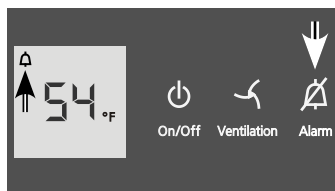



Figure 14

Interior Light - Figure 15

The interior light comes on always when the door is opened and illuminates with its maximum brightness.

When the door is shut, the interior light turns off or if the light function is activated, it will dim to its set level.

To switch the interior light on: Press the **Light** button. The  symbol in the display lights up.

To switch the interior light off: Press the **Light** button. The  symbol in the display goes out.

Adjusting the brightness of the interior light

Press and hold the **Light** button and at the same time press the temperature setting buttons to increase or decrease the brightness.

Down = darker , **Up** = brighter

WARNING

The interior light emits class 1M laser radiation. **DO NOT** look directly at light or through any optical instruments when the light cover is removed. Severe eye injury can occur.

WARNING

The lighting may only be replaced by the customer service technician or by competent skilled personnel! Do not try to change the defective lighting yourself!

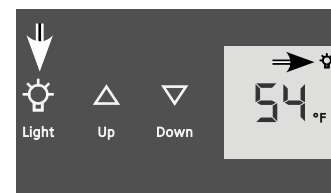

Figure 15

OPERATION

Setup Mode

In the setup mode you can activate the following functions:

☐ = Sabbath mode

h = Display brightness

□ = Temperature display mode

☐ = Child lock

How to activate the setup mode:

- Press the **Ventilation** button for approximately five seconds

- after 5 seconds ☐ will flash in the display.

The appliance is in the setup mode now.

You can select the setup mode functions by pressing the **Up/Down** buttons.

Note

In the setup mode the display will flash continuously.

Exit setup mode:

- Press the **On/Off** button. The appliance will change back to normal operation.

☐ = Sabbath Mode

This feature considers the Religious requirements on Sabbath or Holidays. When the Sabbath Mode is active some functions of the electronic controls are switched off.

The door can be opened and closed at any time.

- The lighting remains off.
- The cooling fan remains in its actual state: If it is on it remains on, if it is off it remains off.
- There is no door alarm.
- There is no temperature alarm.
- The unit will return into Sabbath Mode after a power failure.

How to activate the Sabbath Mode

- Activate the setup mode by pressing the **Ventilation** button for 5 seconds

- the display shows ☐.

- Press the **Ventilation** button

- the display shows 

- Press the **Ventilation** button again

- the display shows 

- the Sabbath mode is activated.

- Exit setup mode by pressing the **On/Off** button.

How to deactivate the Sabbath Mode

- Activate the setup mode by pressing the **Ventilation** button for 5 seconds

- the display shows ☐.

- Press the **Ventilation** button

- the display shows 

- Press the **Ventilation** button again

- the ☐ symbol 

in the display disappears,
the Sabbath mode is deactivated.

- Exit setup mode by pressing the **On/Off** button.

h = Display brightness

How to adjust the display brightness

- Activate the setup mode by pressing the **Ventilation** button for 5 seconds.
- Press the **Down** button until **h** appears in the display.
- Press the **Ventilation** button

- the display shows 

- Press **Up/Down** buttons to select
h 0 = minimum to
h 5 = maximum brightness.
- Press the **Ventilation** button at the desired value.
- Exit setup mode by pressing the **On/Off** button.

□ = Temperature display mode

You can choose the **unit of temperature** for the display in degrees Fahrenheit or degrees Celsius.

Note

The factory setting is degrees Fahrenheit.

How to change the temperature display to degrees Celsius

- Activate the setup mode by pressing the **Ventilation** button for 5 seconds.
- Press the **Down** button until **□** appears in the display.
- Press the **Ventilation** button

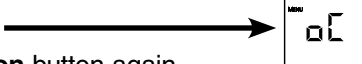
- the display shows 

- Press the **Ventilation** button again
- the temperature reading is now displayed in degree Celsius.
- Exit setup mode by pressing the **On/Off** button.

Note

To change the temperature display back to degrees Fahrenheit, follow the steps above.

⊞ = Child lock

The child lock is designed to protect the appliance from being turned OFF accidentally.

How to activate the child lock

- Activate the setup mode by pressing the **Ventilation** button for 5 seconds.
- Press the **Down** button until **⊞** appears in the display.
- Press the **Ventilation** button

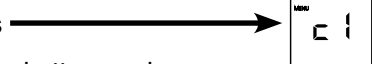
- the display shows 

- Press the **Ventilation** button again
- the LED  is lit and the child lock is activated.
- Exit setup mode by pressing the **On/Off** button.

How to deactivate the child lock

- Activate the setup mode by pressing the **Ventilation** button for 5 seconds.
- Press the **Down** button until **⊞** appears in the display.
- Press the **Ventilation** button

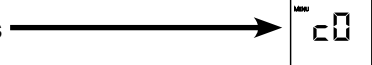
- the display shows 

- Press the **Ventilation** button again
- the LED  goes out. The child lock is deactivated.
- Exit setup mode by pressing the **On/Off** button.

WINE COOLER COMPARTMENT

Equipment - Figure 16

Pull-out grid shelves

The pull-out grid shelf allows bottles of wine to be removed more easily.

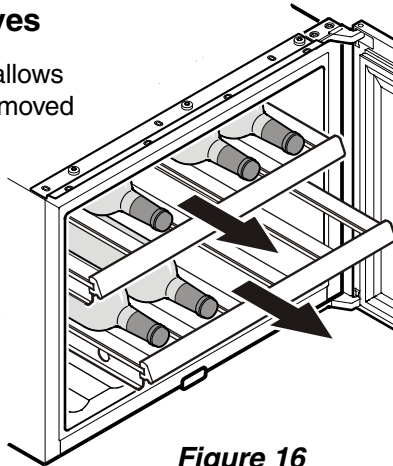

Figure 16

Air Exchange with Activated Charcoal Filter - Figure 17

The way in which wines continue to mature depends on the ambient conditions. The quality of the air is therefore decisive for preserving the wine. Your Liebherr wine cooler is equipped with an activated charcoal filter in the interior rear wall.

We recommend you replace the filters at least once a year. Filters can be obtained from your Liebherr Dealer or Distributor.

Removing the filter: Hold the filter by the handle. Turn it 90° to the left or right and remove.

Reinstalling the filter: Insert with the handle in a vertical position. Turn it 90° to the left or right until it clicks into place.

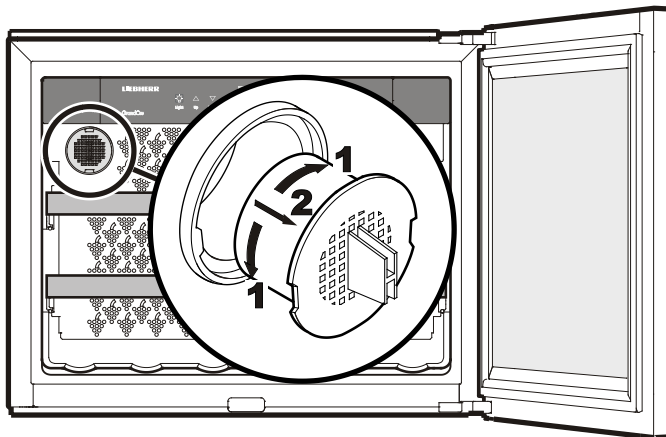

Figure 17

Storing Wine

If you are storing wine for long periods of time, it should be stored at a temperature of between 50°F and 57°F.

This is the temperature wine cellars are kept at, and it is just right to allow wine to mature properly.

The following drinking temperatures are recommended for the various types of wine.

Red wines: **57°F to 64°F**

Rosé wines: **50°F to 54°F**

White wines: **46°F to 54°F**

Sparkling wines, Prosecco: **45°F to 48°F**

Champagne: **41°F to 45°F**

Storage diagram - Figure 18

(for 750 ml Bordeaux bottles)

Total: 18 bottles

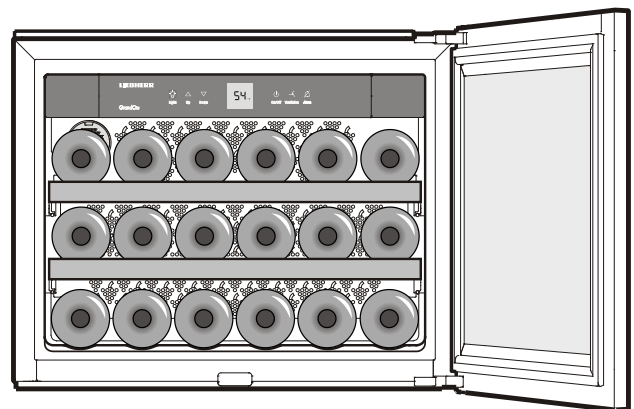

Figure 18

Tall wine bottles can also be stored crossways in the appliance (**Figure 19**).

To ensure stable storage of the bottles, click the retaining plates provided onto the middle slat of the wooden shelf.

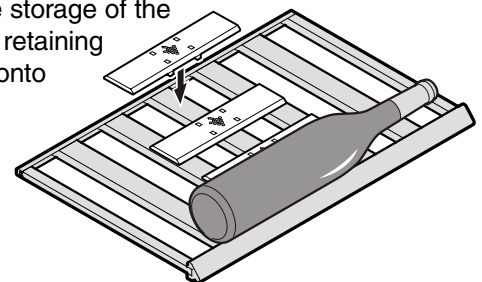

Figure 19

DEFROSTING/CLEANING

Defrosting

The wine cooler compartment defrosts automatically. The water that forms on the rear wall drains into a reservoir at the back of the appliance and evaporates automatically through the compressor heat.

Cleaning



WARNING



- To prevent possible injury due to an electrical shock, be sure to disconnect the power cord or turn off the circuit breaker before cleaning the appliance.
 - To avoid injury or damage, do not use steam cleaning equipment to clean the appliance.
-
- Clean the inside of the appliance, except the wooden grid shelves, with lukewarm water and a little detergent.



WARNING

To avoid short-circuits, ensure no cleaning water penetrates into the electrical components when cleaning the appliance. Do not use a sponge or cloth that is overly wet.

Do not use abrasive or scouring sponges. **Do not** use concentrated cleaning agents. **Never** use abrasive or acid cleaners or chemical solvents or steam cleaners.

- Clean the side panels and door surfaces with a clean and soft cloth. If necessary, use a moist cloth (water + detergent). Alternatively, use a micro-fibre cloth.
- Use a glass cleaner to clean the glass surfaces.
- Dry all parts well with a cloth.
- **Do not** damage or remove the model plate on the inside of the appliance. It is very important for servicing your appliance.

IMPORTANT

Mold can form on the bottles and labels depending on the type of adhesive used on the labels. This can be prevented by carefully cleaning any adhesive residues off the bottles.

TROUBLESHOOTING

Your appliance is designed and manufactured for a long life and reliable operation.

If a problem occurs during operation, check whether it is due to an operating error. Please note that even during the warranty period, some repair costs may be your responsibility.

You may be able to correct the following faults by checking the possible causes yourself:

Problem	Possible Cause and Remedy
Appliance does not work, display is off	<ul style="list-style-type: none">- Is the appliance turned on properly?- Is the power cord properly inserted in the outlet?- Is the circuit breaker or fuse in operating condition?
The interior light does not come on	<ul style="list-style-type: none">- Is the appliance turned on?- Is the interior light turned on?- The interior light is defective. Contact your Liebherr Dealer or Representative.
Motor seems to run too long	<ul style="list-style-type: none">- Is the ambient temperature too hot? See Safety Regulations.- Has the appliance been opened too often or left open too long?- Are proper ventilation requirements met?
The temperature is not cold enough	<ul style="list-style-type: none">- Is the temperature setting correct? See Setting the Temperature.- Does a separately installed thermometer show the correct reading?- Is the ventilation system working properly?- Is the appliance set up too close to a heat source?
<i>F8</i> appears in the display	The appliance has a fault. Contact your nearest customer service representative, indicate the type of appliance, service number and appliance / serial number.

Customer Service

If none of the above possible causes apply, and you can not rectify the fault yourself, contact your nearest customer service representative. Indicate the type **(1)** of appliance, service number **(2)** and the appliance / serial number **(3)** as indicated on the model plate. The model plate is located on the left-hand inside wall.

Appliance Information

Record this information when the appliance is installed.

Type Designation: _____

Service Number: _____

Appliance / Serial Number: _____

Date of Purchase: _____

Where Purchased: _____

LIEBHERR WARRANTY PLAN

FULL TWO YEAR WARRANTY

For two years from the date of original purchase, your Liebherr warranty covers all parts and labor to repair or replace any part of the product which proves to be defective in materials or workmanship.

FULL FIVE YEAR WARRANTY

For five years from the date of original purchase, your Liebherr warranty covers all parts and labor to repair or replace any components that prove to be defective in materials or workmanship in the sealed system. The “Sealed System” means only the compressor, condenser, evaporator, drier and all connecting tubing.

LIMITED 6TH THROUGH 12TH YEAR WARRANTY

From the 6th through 12th year from the date of original purchase, your Liebherr warranty covers all parts that prove to be defective in materials or workmanship in the Sealed System (parts only).

TERMS APPLICABLE TO EACH WARRANTY

All service provided by Liebherr under the warranty must be performed by authorized Liebherr service representatives, unless otherwise specified by Liebherr. Service will be provided in the home during normal business hours. This warranty applies only to products installed for normal residential use. Details regarding a non-residential warranty are available on request.

The warranty applies only to products installed in Canada and any one of the fifty states of the United States or the District of Columbia. This warranty does not cover any parts or labor to correct any defect caused by negligence, accident or improper use, maintenance, installation, service or repair, including but not limited to improper removal and reinstallation of the condensing unit.

THE WARRANTIES DESCRIBED ABOVE ARE MADE EXPRESSLY IN LIEU OF ANY OTHER WARRANTIES, EXPRESSED OR IMPLIED, INCLUDING ANY IMPLIED WARRANTY OF MERCHANTABILITY OR FITNESS FOR A PARTICULAR PURPOSE, AND OF ANY OTHER OBLIGATION OR LIABILITY ON THE PART OF LIEBHERR. IN NO EVENT SHALL LIEBHERR BE LIABLE FOR SPECIAL, INCIDENTAL OR CONSEQUENTIAL DAMAGES ARISING FROM THE BREACH OF THESE WARRANTIES OR ANY OTHER WARRANTIES, WHETHER EXPRESS, IMPLIED OR STATUTORY.

Some States do not allow the exclusion or limitation of incidental or consequential damages so the above limitation or exclusion may not apply to you. This warranty gives you specific legal rights and you may also have other rights which vary from State to State.

To receive parts and/or service and the name of the Liebherr authorized service representative nearest you, contact your Liebherr dealer or distributor or contact the Liebherr designated national service provider:

in the US: Service-appliances.us@liebherr.com, or call 1-866-LIEBHER or 1-866-543-2437

in Canada: www.euro-parts.ca, or call 1-888-LIEBHER, 1-888-543-2437.