

INSTALL
COLUMN REFRIGERATION
MULTIPLE UNITS

INSTALLATION
DE RÉFRIGÉRATEURS
PLUSIEURS UNITÉS

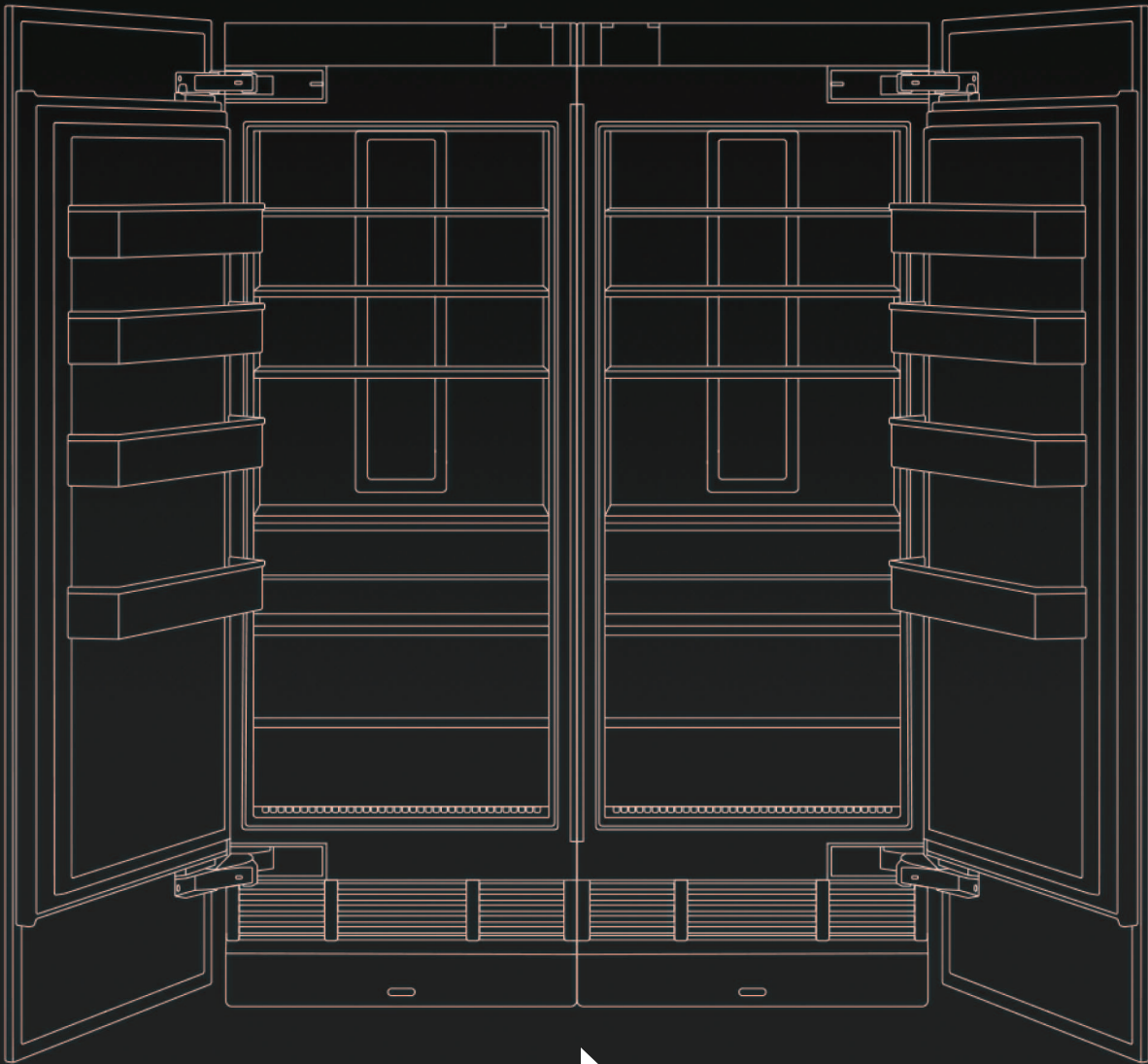

Your safety and the safety of others are very important.

We have provided many important safety messages in this manual and on your appliance. Always read and obey all safety messages.



This is the safety alert symbol.

This symbol alerts you to potential hazards that can kill or hurt you and others.

All safety messages will follow the safety alert symbol and either the word “DANGER” or “WARNING.” These words mean:

⚠ DANGER

You can be killed or seriously injured if you don't immediately follow instructions.

⚠ WARNING

You can be killed or seriously injured if you don't follow instructions.

All safety messages will tell you what the potential hazard is, tell you how to reduce the chance of injury, and tell you what can happen if the instructions are not followed.

IMPORTANT SAFETY INSTRUCTIONS

WARNING: To reduce the risk of fire, electric shock, or injury when using your refrigerator, follow these basic precautions:

- To avoid a hazard due to instability of the appliance, it must be fixed in accordance with the instructions.
- Plug into a grounded 3 prong outlet.
- Installation shall be performed only by manufacturer, or an authorized agent.
- Do not remove ground prong.
- Do not use an adapter.
- Do not use an extension cord.
- Disconnect power to all units before servicing.
- Replace all parts and panels before operating.
- Remove doors from your old refrigerator.
- Use nonflammable cleaner.
- Do not store or use petrol, flammable liquids or gas in the vicinity of this or other electrical appliances. The fumes can cause fires or explosions.
- Do not store explosive substances such as aerosol cans with a flammable propellant in this refrigerator.
- Do not use or place electrical devices inside the refrigerator compartments if they are not of the type expressly authorized by the manufacture.
- Use two or more people to move and install refrigerator.
- Disconnect power before installing ice maker (on ice maker kit ready models only).
- A qualified service technician must install the water line and ice maker. See installation instruction supplied with ice maker kit IC13B for complete details.
- Connect to a potable water supply only.
- Use a sturdy glass when dispensing ice (on some models).
- This appliance is not intended for use by persons (including children) with reduced physical, sensory or mental capabilities, or lack of experience and knowledge, unless they have been given supervision or instruction concerning use of the appliance by a person responsible for their safety.
- Children should be supervised to ensure that they do not play with the appliance.
- To avoid the risk of children becoming trapped and suffocating, do not allow them to play or hide inside the refrigerator.
- If the supply cord is damaged, it must be replaced by the manufacturer, its service agent or similarly qualified person in order to avoid a hazard.
- This refrigerator is intended to be used in household and similar applications such as:
 - staff kitchen areas in shops, offices, and other working environments
 - farm houses and by clients in hotels, motels, and other residential type environments
 - bed and breakfast type environments
 - catering and similar non-retail applications

SAVE THESE INSTRUCTIONS

⚠️ WARNING

Suffocation Hazard

Remove doors from your old refrigerator.

Failure to do so can result in death or brain damage.

Important information to know about disposal of refrigerants:

Dispose of refrigerator in accordance with Federal and Local regulations. Refrigerants must be evacuated by a licensed, EPA certified refrigerant technician in accordance with established procedures.

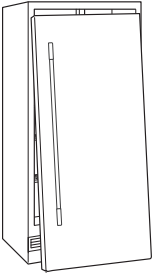

IMPORTANT: Child entrapment and suffocation are not problems of the past. Junked or abandoned refrigerators are still dangerous – even if they will sit for "just a few days." If you are getting rid of your old refrigerator, please follow these instructions to help prevent accidents.

Before You Throw Away Your Old Refrigerator or Freezer:

- Take off the doors.
- Leave the shelves in place so that children may not easily climb inside.

E A S E . S P E E D . S A F E T Y .

With the launch of the first ever JennAir® columns, we reimaged the entire column installation process, eliminating problems that affect our sub-par competitors. Some of the features professional installers are most excited about:

- **Concealed six-point panel adjustment**
Easy and precise alignment
- **Site-tailored Rotter system shims and badass bracket**
Guide and keep column in position
- **Precision four-point front leveling**
On sturdy rollers that easily bear full weight
- **Metal fascia**
Increases durability
- **Solid wood core stainless steel panels**
Easy to prep and hang and do not require drilling through steel
- **Expanded utility areas**
Reduced changes to replace built-ins or upgrade from competitor columns

And with your help, we'll just keep getting better.

Contact the JennAir Epicenter through jennair.com or at **1-800-JENNAIR (536-6247)** to report installation tips and tricks, or to consult with experts who know the installation process inside and out.

W H Y W E L O V E J E N N A I R I N S T A L L E R S

THEY'RE TOTAL PROFESSIONALS AND PERFECTIONISTS .

It's all about getting that seamless flush execution, that down-to-the-millimeter adjustment. Flawless installation is incredibly important to the function, appearance and lifetime enjoyment of our products, and our installers make it happen every day.

THEY DO THEIR HOMEWORK. AND HELP US WITH OURS.

These experts know JennAir® products inside and out. They train extensively on JennAir installation, learning the latest techniques and insider tips so they can install our cutting edge appliances with ease. And we value their input, incorporating installer feedback to refine and perfect our installations.

THEY THINK THROUGH EVERY DETAIL OF THE EXPERIENCE.

Above and beyond dedication is the baseline. The JennAir experience starts the minute an installer brings the customer's column home. Keeping the site spotless, taking extreme care with both the appliances and the home and providing an unforgettable introduction to columns is all part of the game plan.

TABLE OF CONTENTS

INTRODUCTION

02	SAFETY INSTRUCTIONS
06	TOOLS & PARTS
08	JOIN KITS
11	CONFIGURATIONS
13	PRODUCT DIMENSIONS
15	DOOR STYLE
16	OPENING DIMENSIONS
21	SITE PREP
24	INSTRUCTION KEY

PREPARATION

25	SECTION 1	PREPARE COLUMNS
32	SECTION 2	PREPARE JOIN KIT
37	SECTION 3	PREPARE POSITIONING BRACKET
40	SECTION 4	BADASS BRACKET INSTALLATION
49	SECTION 5	PREPARE FURNITURE

INSTALLATION

55	SECTION 6	FIRST COLUMN INSTALLATION
65	SECTION 7	SECOND COLUMN INSTALLATION
73	SECTION 8	THIRD COLUMN INSTALLATION
81	SECTION 9	PREPARE COLUMN FOR USE

ACCESSORIES

87	SECTION 10	TOE KICK: CUSTOM WOOD PREPARATION
90	SECTION 11	TOE KICK: STAINLESS STEEL PREPARATION
93	SECTION 12	TOE KICK: ALIGN AND INSTALL
98	SECTION 13	PANEL: CUSTOM WOOD PREPARATION
103	SECTION 14	PANEL: STAINLESS STEEL PREPARATION
106	SECTION 15	PANEL: HANG AND ALIGN

COMPLETE

113	SECTION 16	COMPLETE INSTALLATION
116		FINAL CHECKLIST

120 TABLE DES MATIÈRES

TOOLS + PARTS PROVIDED

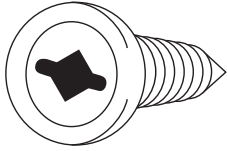

#2 Square-drive screws
(3-24004-079)

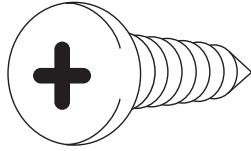

8-18 x 3/4
Phillips head screws
(W 11041176)

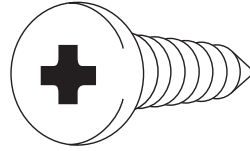

6-20 x .375 screws
(246131)

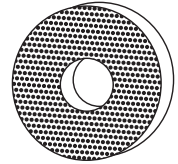

Gripping pads
(W 10840464)

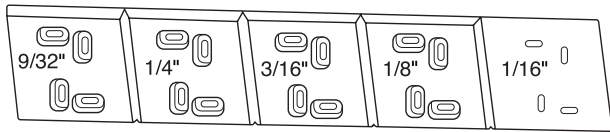

Five installation shims
(W 10913387)

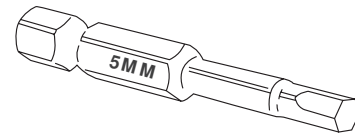

5 mm driver bit
(W 11121505)

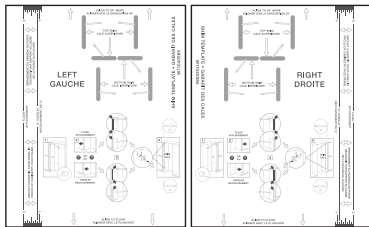

Shim installation template
(W 11040585)

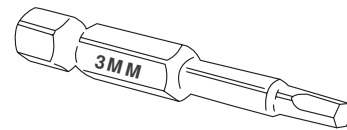

3 mm driver bit
(W 11121512)

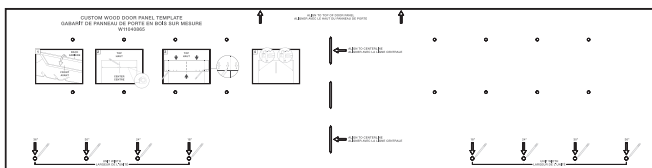

Toe-kick and door panel installation template
(W 11040865)

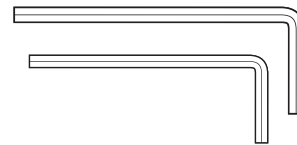

3 mm †Allen® wrench
5 mm Allen® wrench



READ AND FOLLOW THE INSTRUCTIONS PROVIDED WITH ANY OF THE TOOLS LISTED.

†®Allen is a registered trademark of Apex Brands, Inc.

TOOLS + PARTS

NOT PROVIDED

TOOLS
<input type="checkbox"/> Cordless drill and drill bits or im pact driver
<input type="checkbox"/> Drill bit set including 3/32" and 1/8" diam eter bits
<input type="checkbox"/> Two adjustable wrenches
<input type="checkbox"/> #2 Phillips bit
<input type="checkbox"/> 1/4" m agnetic nut driver
<input type="checkbox"/> #2 square-drive bit
<input type="checkbox"/> 48" or longer level or straight edge (Can substitute a factory-installed trim piece, once rem oved.)
<input type="checkbox"/> 3/8" and 1/2" open-end wrenches
<input type="checkbox"/> Tape m easure
<input type="checkbox"/> Utility knife
<input type="checkbox"/> Masking tape
<input type="checkbox"/> Appliance dolly
<input type="checkbox"/> Right angle drill adapter
<input type="checkbox"/> 6" drill extension
<input type="checkbox"/> #8 pan head wood screws of assorted lengths including 1", 1-1/4", 1-1/2"

PARTS
<input type="checkbox"/> Flexible code-approved water supply line
<input type="checkbox"/> Custom door overlay panels <ul style="list-style-type: none"> • Stainless steel panels: order from JennAir • Custom wood panels: consult a qualified cabinetm aker or carpenter
<input type="checkbox"/> Additional fasteners will be required according to the kitchen furniture construction

WHY USE ROTTER SYSTEM SHIMS AND THE BADASS BRACKET?

This recom m ended process m ight be unfam iliar to you as an installer, but it adds enorm ous value to both you and your client. Use the Rotter system to:

- Help position column without scratching
- Create precise 1/8" reveals on each side
- Always have ready-m ade shim s tailored to each site
- Keep column stable in cutout over lifetim e
- Elim inate m isalignm ent issues for your client

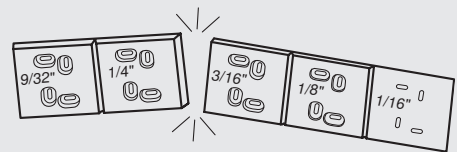

JOIN KITS

SOLD SEPERATELY

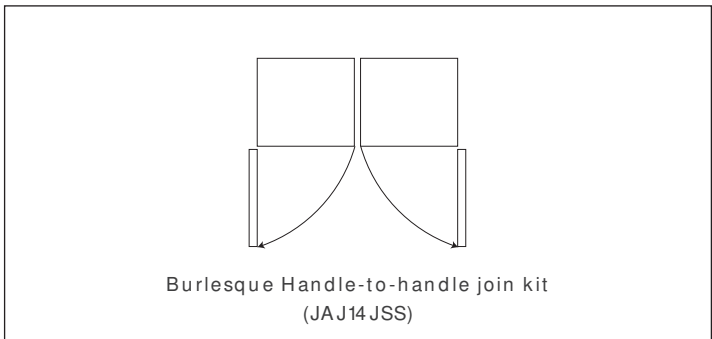
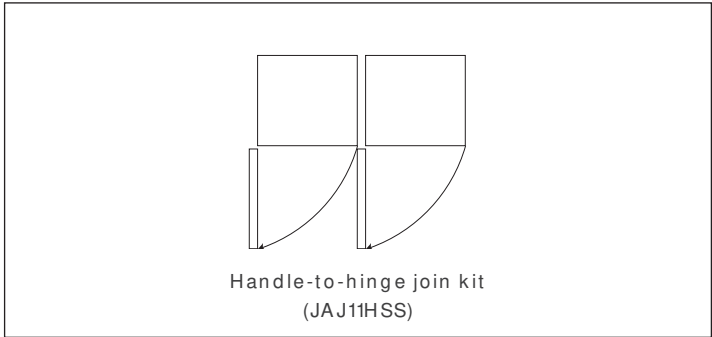
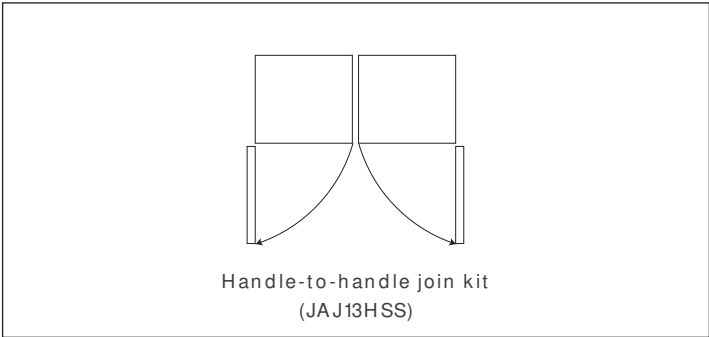

TOOLS AND PARTS INCLUDED IN JOIN KITS

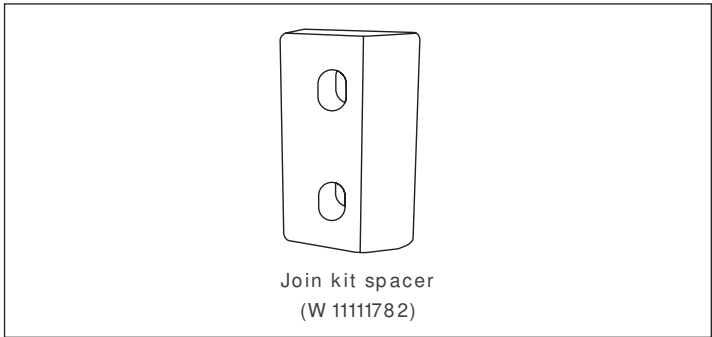
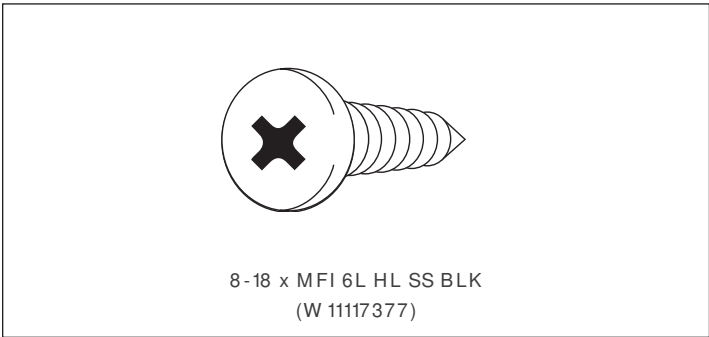
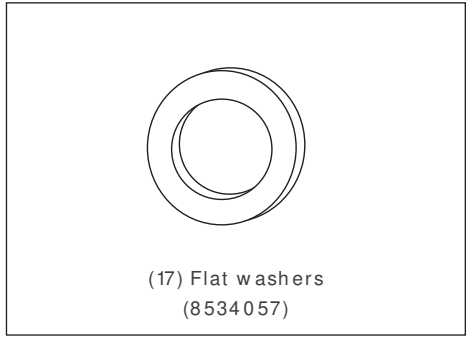
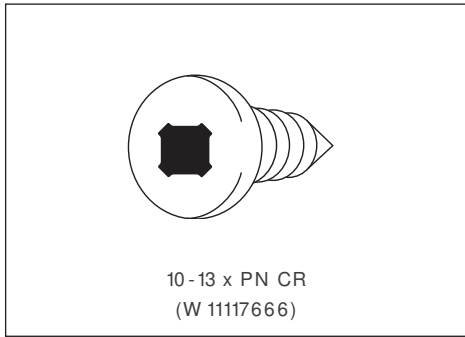
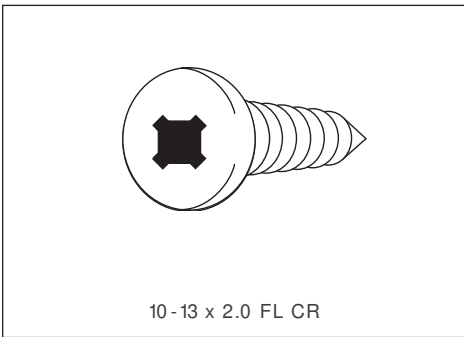

 READ AND FOLLOW THE INSTRUCTIONS PROVIDED WITH ANY OF THE TOOLS LISTED.

JOIN KITS

SOLD SEPERATELY

TOOLS AND PARTS INCLUDED IN JOIN KITS CONTD.

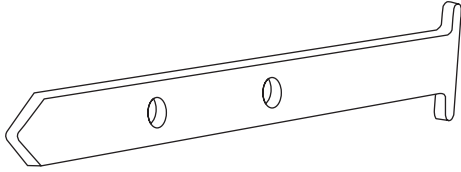

Positioning bracket mount
(W 11111772)

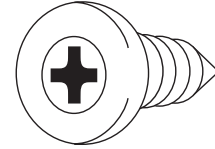

(14) 8-15 x "L" Mtr cr cone screws
(828 1252)

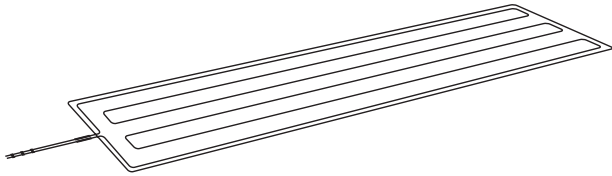

Peel and stick heating pad
(W 10912090)

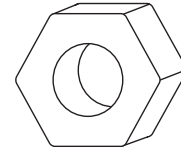

(8) M6-1 x 6 10 mm metric hex nuts
(W 10854505)

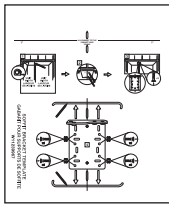

Soffit bracket installation template
(W 11040584)

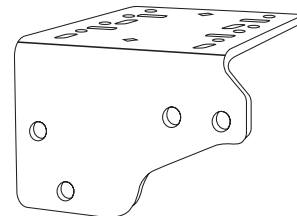

Badass soffit bracket
(W 11111754)

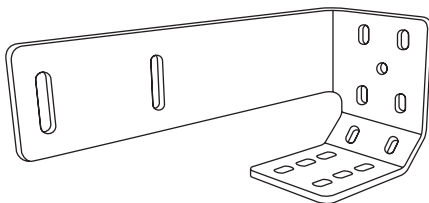

Positioning bracket
(W 1111177 1)



READ AND FOLLOW THE INSTRUCTIONS PROVIDED WITH ANY OF THE TOOLS LISTED.

JOIN KITS

SOLD SEPERATELY

TOOLS AND PARTS INCLUDED IN JOIN KITS CONTD.

Handle-to-handle join kit

Left-hand (handle) trim
(W 11103734)

Right-hand (handle) trim
(W 11103737)

Handle-to-hinge join kit

Left-hand (handle) trim
(W 11103734)

Right-hand (hinge) trim
(W 11103736)

Hinge-to-handle join kit

Left-hand (handle) trim
(W 11103737)

Right-hand (hinge) trim
(W 11103735)

CONFIGURATIONS

2 UNITS

⚠ CAUTION

Pinch Hazard

Installation of door panels with less than a 3/8" (0.95 cm) gap between the door panel and the adjacent cabinet increases the risk of potential pinching.

PERMISSIBLE 2 UNIT CONFIGURATIONS

Handle-to-handle
join kit
(JAJ13HSS)

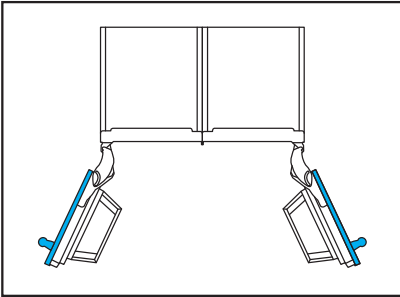

Hinge-to-handle
join kit
(JAJ12HSS)

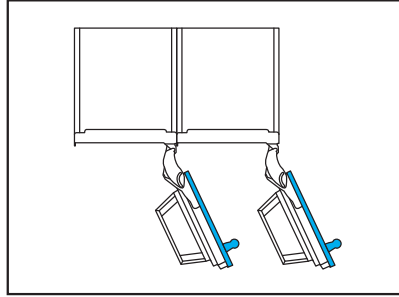

Handle-to-hinge
join kit
(JAJ11HSS)

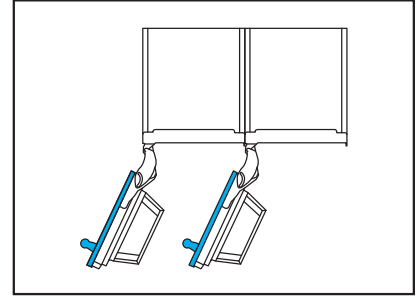

NON PERMISSIBLE 2 UNIT CONFIGURATIONS

Hinge-to-hinge

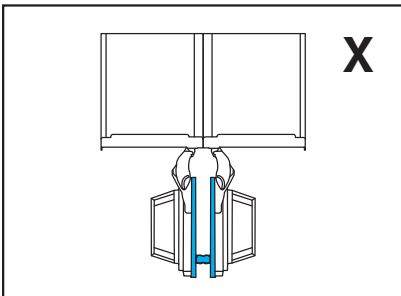

CONFIGURATIONS

3 UNITS

PERMISSABLE 3 UNIT CONFIGURATIONS

Handle-to-hinge and
handle-to-hinge
join kits:
JAJ11HSS (X2)

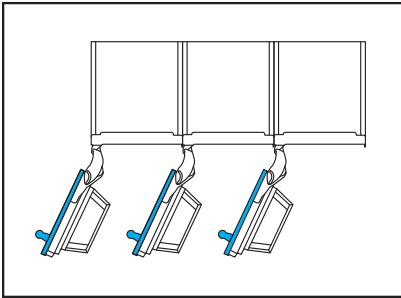

Hinge-to-handle and
hinge-to-handle
join kits:
JAJ12HSS (x2)

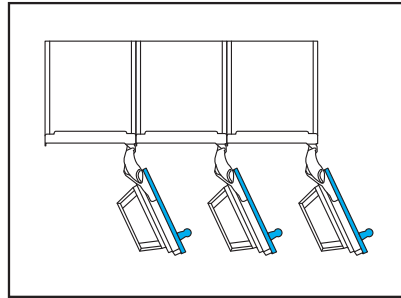

Handle-to-hinge and
handle-to-handle
join kits:
JAJ11HSS and JAJ13HSS

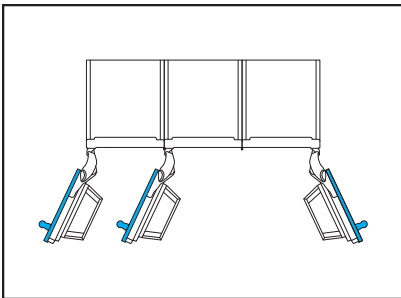

Handle-to-handle and
hinge-to-handle
join kits:
JAJ13HSS and JAJ12HSS

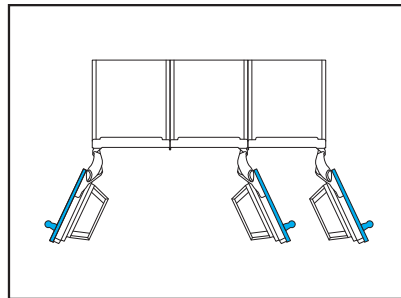

NON PERMISSABLE 3 UNIT CONFIGURATIONS

Hinge-to-hinge

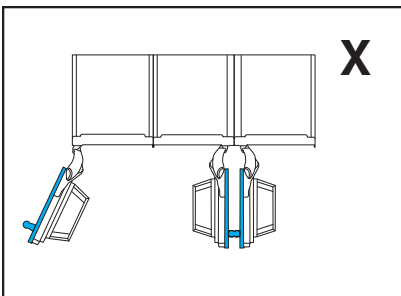

Hinge-to-hinge

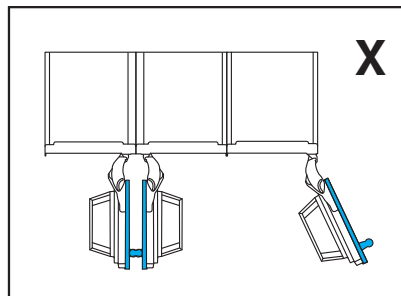

DIMENSIONS

PRODUCT

OVERALL PRODUCT NO PANEL

Width	See unit width table below
Height	79-7/8" – 85-5/16" (202.9 – 215.9 cm)
Depth	24-1/8" (61.3 cm)
Raw Door Height	79-7/8" (202.9 cm)
Toe-kick Height	3-9/16" (9.1 cm)
Toe-kick Depth	3-1/4" – 4-7/8" (8.3 – 12.4 cm)

PRODUCT WIDTH

Model	Width
18" JBZFR18IGX JBZFL18IGX ALOVE18FL	17-3/4" (45.1 cm)
24" JBRFR24IGX JBRFL24IGX JBZFR24IGX JBZFL24IGX ALOVE24FL ALOVE24RR	23-3/4" (60.3 cm)
30" JBRFR30IGX JBRFL30IGX JBZFR30IGX JBZFL30IGX ALOVE30RR	29-3/4" (75.6 cm)
36" JBRFR36IGX JBRFL36IGX	35-3/4" (90.8 cm)

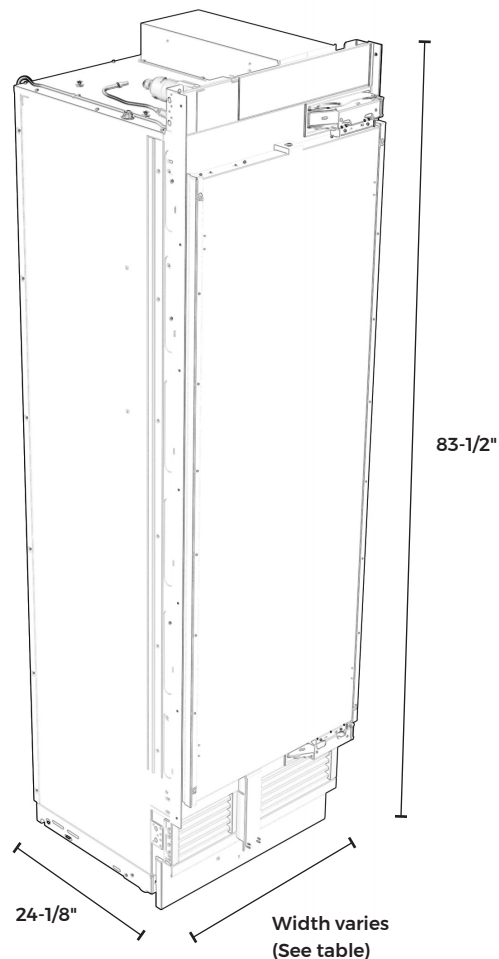

DIMENSIONS

ACCESSORIES

STAINLESS STEEL PANEL

Height	80" (203.2 cm)
Thickness	13/16" (2.1cm)

CUSTOM TOE KICK

Height	3-9/16" (9.1cm)
Thickness	3/16"-3/4" (4.8 – 1.9 m m)

CUSTOM PANEL

Thickness	3/4" (1.9 cm) m ax.
Weight	60 lbs. (27.2 kg) m ax.
Typical Height	80" (203.2 cm)

DOOR STYLE

CUSTOM PANEL WIDTH

⚠ CAUTION

Pinch Hazard

Installation of door panels with less than a $\frac{3}{8}$ " (0.95 cm) gap between the door panel and the adjacent cabinet increases the risk of potential pinching.

MODEL	FLUSH WIDTH
18"	17-3/4" (45.1 cm)
24"	23-3/4" (63.5 cm)
30"	29-3/4" (75.6 cm)
36"	35-3/4" (90.8 cm)

MODEL	OVERLAY WIDTH
18"	18-3/8" (46.7 cm)
24"	24-3/8" (61.9 cm)
30"	30-3/8" (77.2 cm)
36"	36-3/8" (92.4 cm)

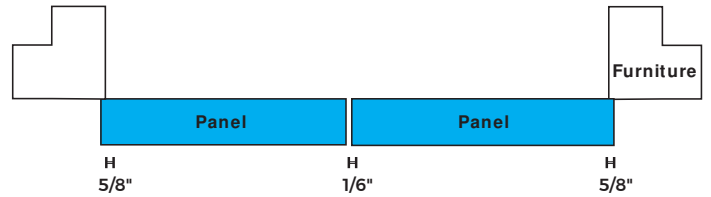
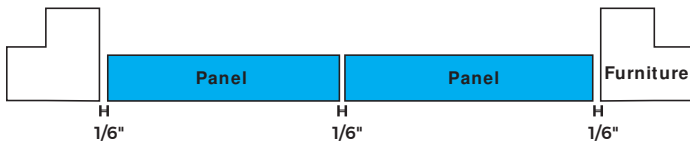

MODEL	FLUSH WIDTH
18"	17-3/4" (45.1 cm)
24"	23-3/4" (63.5 cm)
30"	29-3/4" (75.6 cm)
36"	35-3/4" (90.8 cm)



DIMENSIONS

OPENING

2 UNIT CONFIGURATIONS

NOTE: These diagrams show cutout width of product combinations.

Products may be arranged into any permissible configuration shown on pg. 10-11.

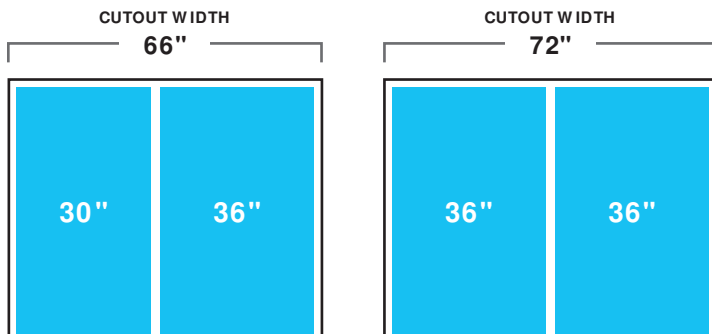
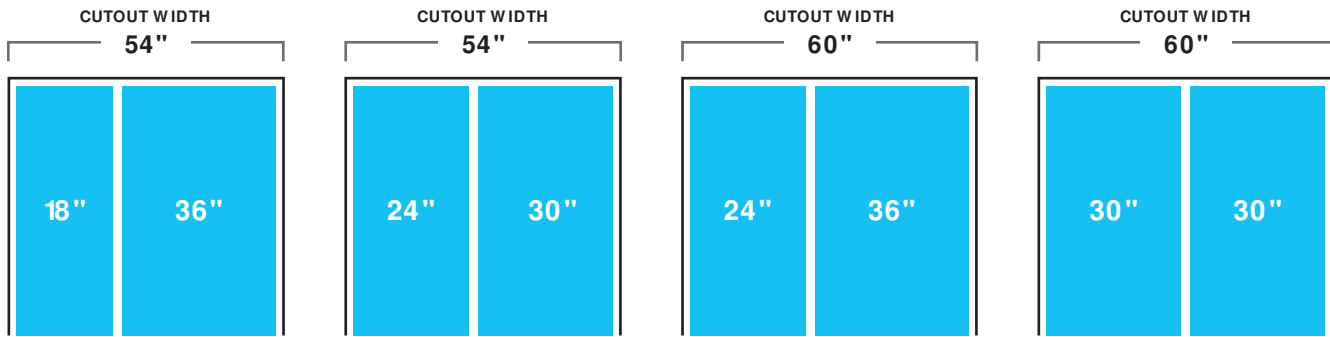
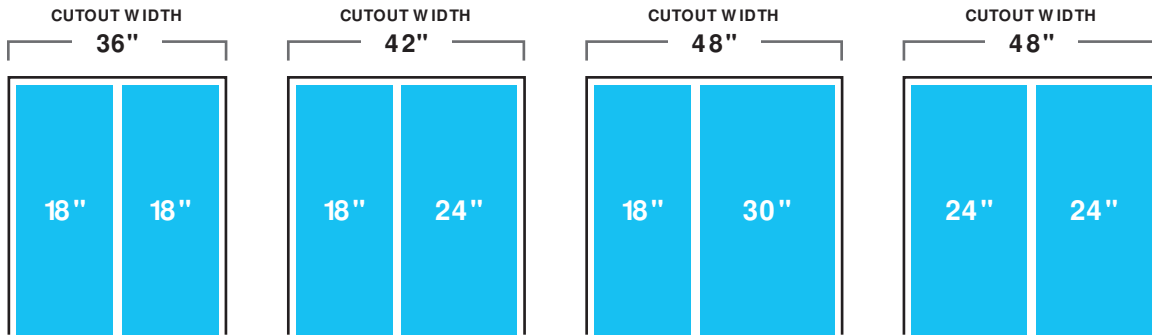

DIMENSIONS

OPENING

3 UNIT CONFIGURATIONS

NOTE: These diagrams show cutout width of product combinations.

Products may be arranged into any permissible configuration shown on pg. 10-11.

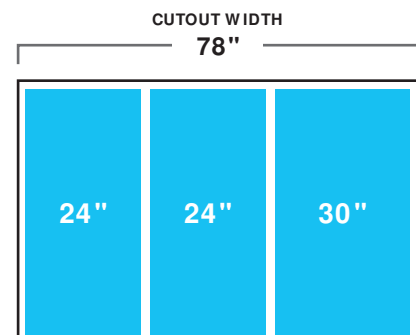
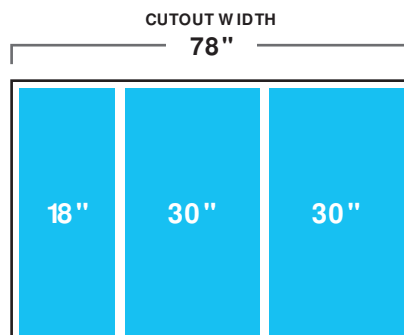
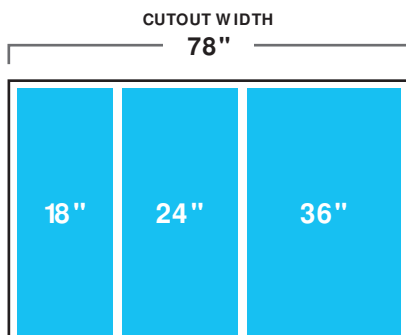
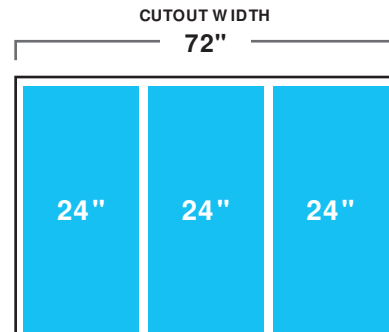
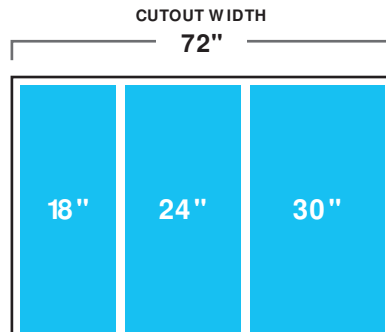
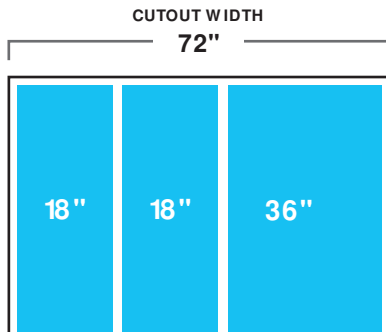
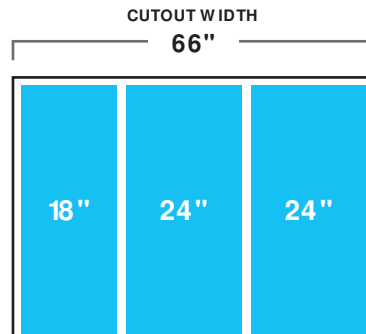
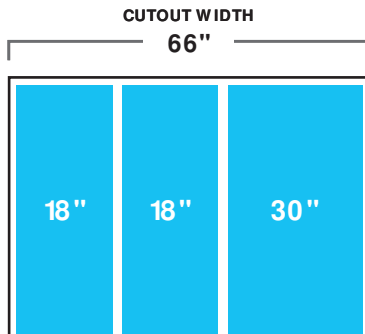
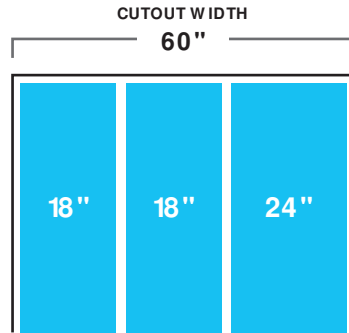
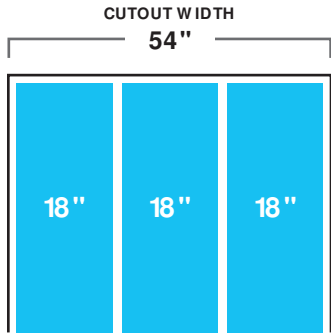

DIMENSIONS

OPENING

3 UNIT CONFIGURATIONS

NOTE: These diagrams show cutout width of product combinations.

Products may be arranged into any permissible configuration shown on pg. 10-11.

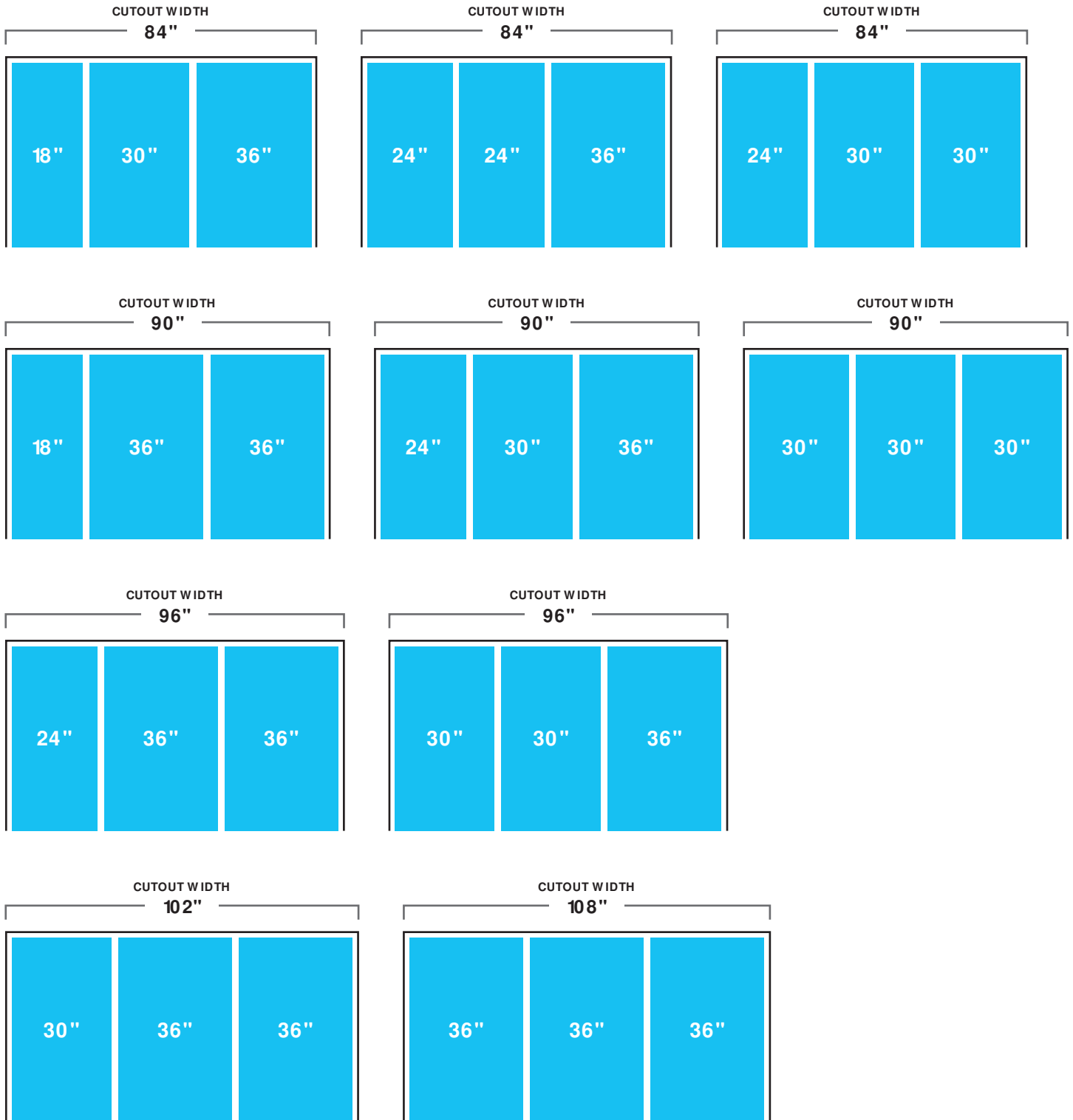

DIMENSIONS

OPENING

⚠ CAUTION

Pinch Hazard

Installation of door panels with less than a $\frac{3}{8}$ " (0.95 cm) gap between the door panel and the adjacent cabinet increases the risk of potential pinching.

DOOR SWING REQUIREMENTS

Model	115° Door Swing "A"	90° Door Swing "B"	Wall Gap "C"	Door Open Depth "D"
18"	10-1/2" (26.7 cm)	5" (12.7 cm)	2-1/2" (6.4 cm)	44-1/2" (113 cm)
24"	13" (33 cm)	5" (12.7 cm)	2-1/2" (6.4 cm)	50-1/2" (128.3 cm)
30"	15-1/2" (39.4 cm)	5" (12.7 cm)	2-1/2" (6.4 cm)	56-3/8" (143.2 cm)
36"	18" (45.7 cm)	5" (12.7 cm)	2-1/2" (6.4 cm)	62-7/16" (158.6 cm)

Dimensions give 2-1/2" spacing between stainless steel handle accessory and wall to avoid pinching. For a custom wood panel, consider handle depth to maintain 2-1/2" spacing.

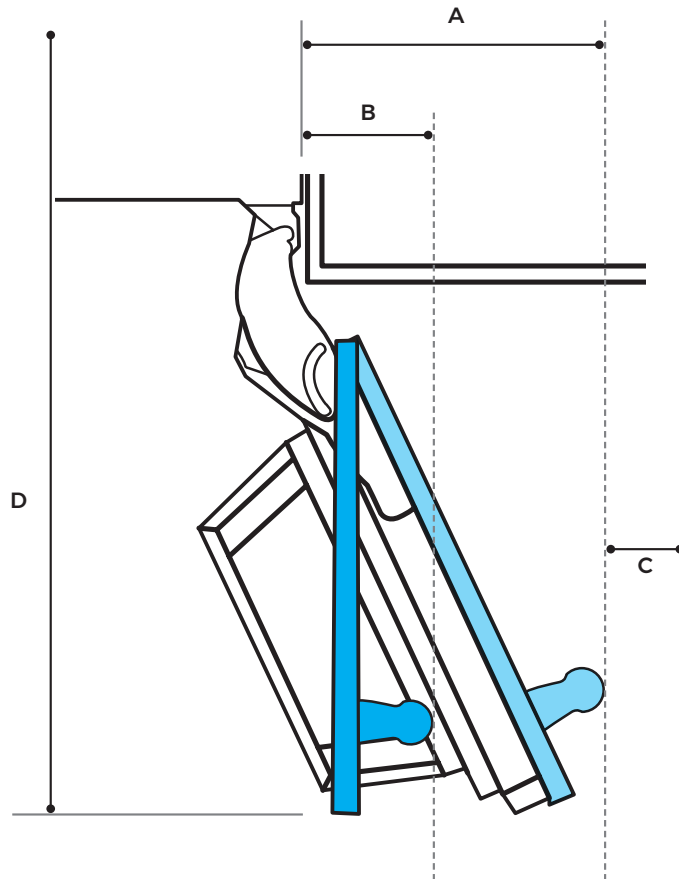

DIMENSIONS

OPENING

OPENING WIDTH

Model	Width (A)
18" JBZFR18IGX JBZFL18IGX ALOVE18FL	18" (45.7 cm)
24" JBRFR24IGX JBRFL24IGX JBZFR24IGX JBZFL24IGX ALOVE24FL ALOVE24RR	24" (61 cm)
30" JBRFR30IGX JBRFL30IGX JBZFR30IGX JBZFL30IGX ALOVE30RR	30" (76.2 cm)
36" JBRFR36IGX JBRFL36IGX	36" (91.4 cm)

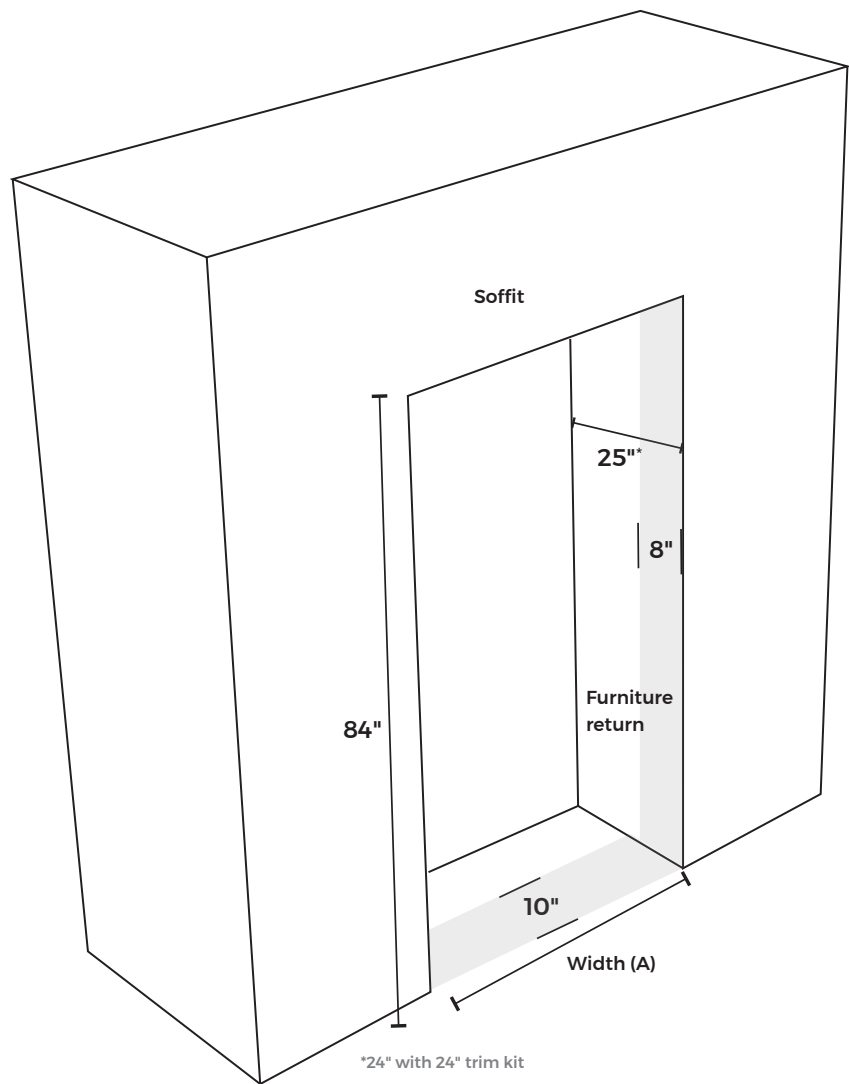

SITE PREP

1. CHECK THE FURNITURE

- Measure to make sure all opening dimensions are correct. (See previous page.)
- Side panel construction: 3/4" (1.9 cm) thick plywood.
IMPORTANT: Cannot be constructed of pressed fiber material such as MDF.
- Soffit height: 84" (213.4 cm).
- A single water supply line may be split 2 or 3 ways to service all columns.

2. CHECK THE INSTALLATION SITE

- Away from ovens, radiators or other heat sources.
- Temperature will not fall below 55° F (13° C).
- Floor supports more than 600 lbs. (272 kg) plus door panel and contents weight.
- Floor level with the room.
- Furniture face plumb.

! WARNING



Explosion Hazard

Keep flammable materials and vapors, such as gasoline, away from refrigerator.

Failure to do so can result in death, explosion, or fire.

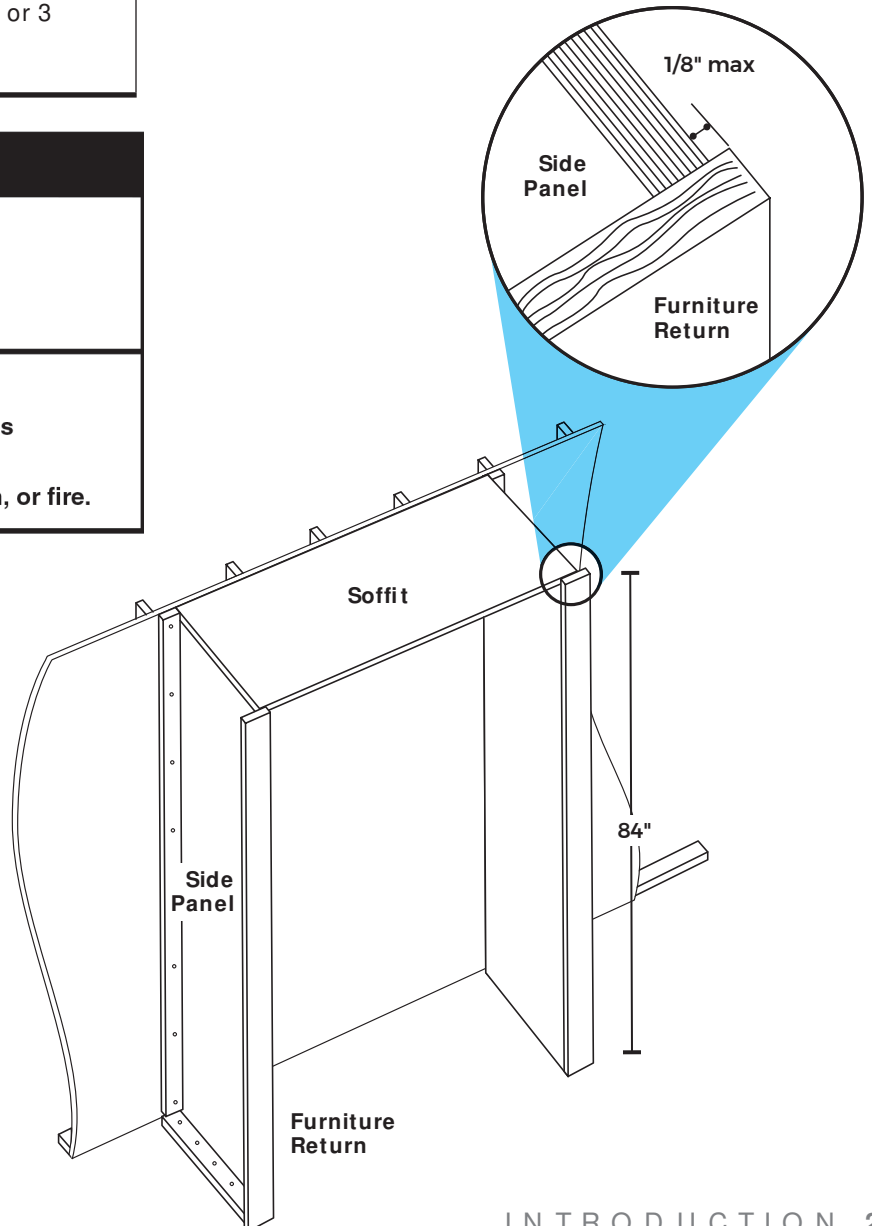

SITE PREP

3. CHECK THE WATER SUPPLY

- Water supply meets local plumbing codes.
- Water shutoff in base cabinet, as shown, or accessible area.
- Access hole through the cabinet is within 1/2" (1.3 cm) of the rear wall.
- Install any additional tubing only where temperatures remain above freezing. Check for leaks.
- Not using a piercing-type or 3/16" (4.8 mm) saddle valve. See refrigerator dealer for saddle-type valve kit that complies with local plumbing codes.
- If water pressure to reverse osmosis system is less than 40 to 60 psi (276 to 414 kPa):
 - Check sediment filter to see if it is blocked. Replace filter if necessary.
 - Allow the storage tank to refill after heavy usage.
 - Remove the water filter cartridge. No filter bypass is necessary.

WATER SUPPLY REQUIREMENTS

Water Pressure	30 – 120 psi (207 – 827 kPa)
Water Pressure to Reverse Osmosis System	Minimum 40 – 60 psi (276 – 414 kPa)
Excess Water Line for Connection	30" (76.2 cm)
Supply	1/4" OD copper, braided stainless steel or PEX tubing

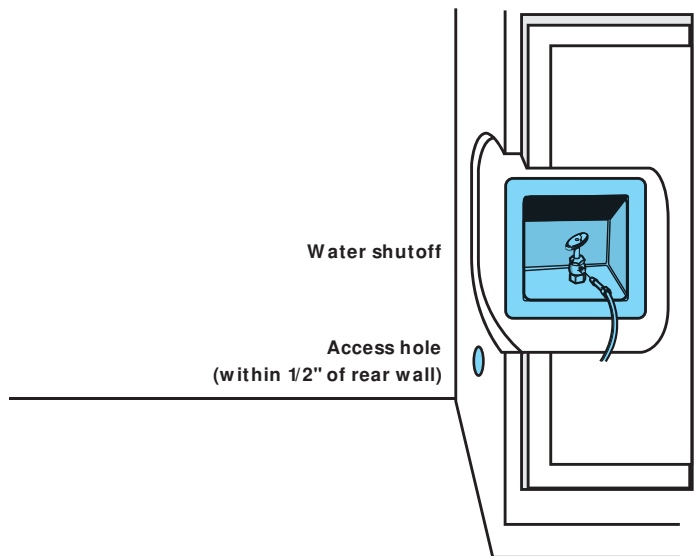

IF YOU HAVE QUESTIONS ABOUT YOUR WATER SUPPLY, CALL A LICENSED, QUALIFIED PLUMBER.

SITE PREP

⚠ WARNING



Electrical Shock Hazard

Plug into a grounded 3 prong outlet.

Do not remove ground prong.

Do not use an adapter.

Do not use an extension cord.

Failure to follow these instructions can result in death, fire, or electrical shock.

4. CHECK THE ELECTRICAL

- Column on a separate circuit. Outlet cannot be turned off by a switch.
- Not using an extension cord.
- Not using a GFCI protected outlet.
- Electrical installed in the zones highlighted. (See graphic to the right.)

ELECTRICAL REQUIREMENTS

Product Width/ Alternate Electrical Zone Width "A"	Electrical Zone Width "B"
18" (45.7 cm)	14-1/2" (36.8 cm)
24" (60.1 cm)	20-1/2" (52 cm)
30" (76.2 cm)	26-1/2" (67.3 cm)
36" (91.4 cm)	32-1/2" (82.6 cm)

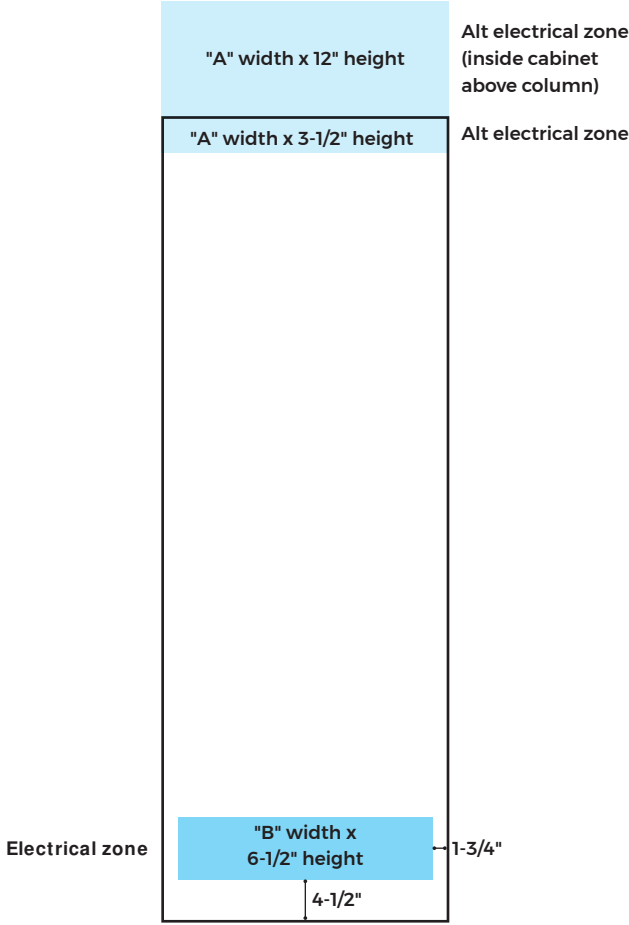

? IF YOU HAVE QUESTIONS ABOUT YOUR ELECTRICAL SUPPLY, CALL A LICENSED, QUALIFIED ELECTRICIAN.

SITE PREP

5. PRE INSTALLATION CHECK

- Verify customer's selected door style.
- Remove all installation materials from the deli drawer.
- Mark selected door style on templates and door depth gauges with a permanent marker.
- Verify that the diagonal measurements of opening match.
- Check design considerations document to verify panel and toe-kick dimensions, as well as gaps and overlays.
- Check for correct join kits based on configuration, left/right side, hinge/non-hinge and installation order.

INSTRUCTION KEY

This helpful key tells you where you'll be performing the steps in the following sections.

Note that columns are installed and numbered from left to right.

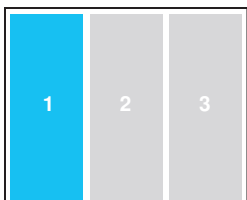

Perform the step on the column highlighted in blue.

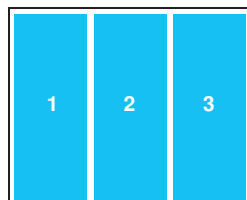

Perform the step on every column you are installing.

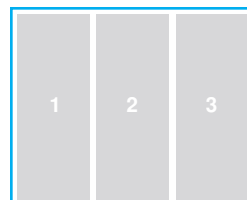

Perform the step on the furniture.

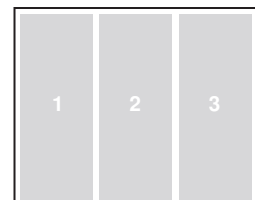

Perform the step on a part that is not attached to a column, such as a door panel or toe-kick.

P R E P A R E
C O L U M N S

1

PREPARE COLUMNS

1.1

UNCRATE COLUMNS AND JOIN KITS, DISCARDING CARTONS.

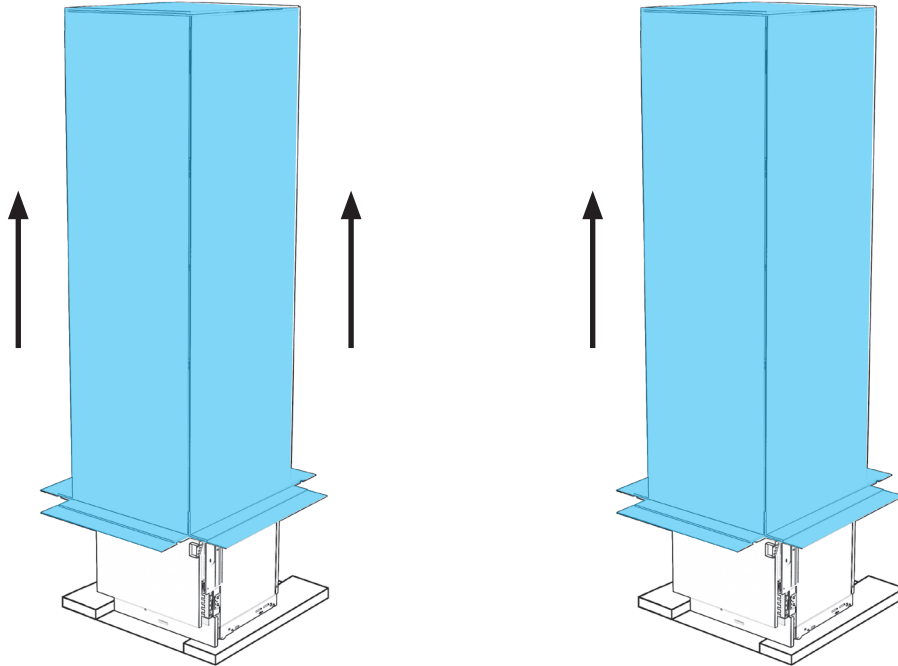

REMOVE INSTALLATION KITS FROM DELI DRAWERS WHILE ON SKIDS.

BEFORE MOVING COLUMNS, REVIEW ALL WARNINGS.

⚠ WARNING



Tip Over Hazard

Refrigerator is top heavy and tips easily when not completely installed.

Keep doors taped closed until refrigerator is completely installed.

Use two or more people to move and install refrigerator.

Failure to do so can result in death or serious injury.

When Moving Your Refrigerator:

Your refrigerator is heavy. When moving the refrigerator for cleaning or service, be sure to cover the floor with cardboard or hardboard to avoid floor damage. Always pull the refrigerator straight out when moving it. Do not wiggle or “walk” the refrigerator when trying to move it, as floor damage could occur.

Important information to know about glass shelves and covers:

Do not clean glass shelves or covers with warm water when they are cold. Shelves and covers may break if exposed to sudden temperature changes or impact, such as bumping. Tempered glass is designed to shatter into many small, pebble-size pieces. This is normal. Glass shelves and covers are heavy. Use both hands when removing them to avoid dropping.

1.2

EACH COLUMN: MOVE IN FRONT OF OPENING.

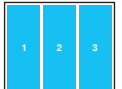
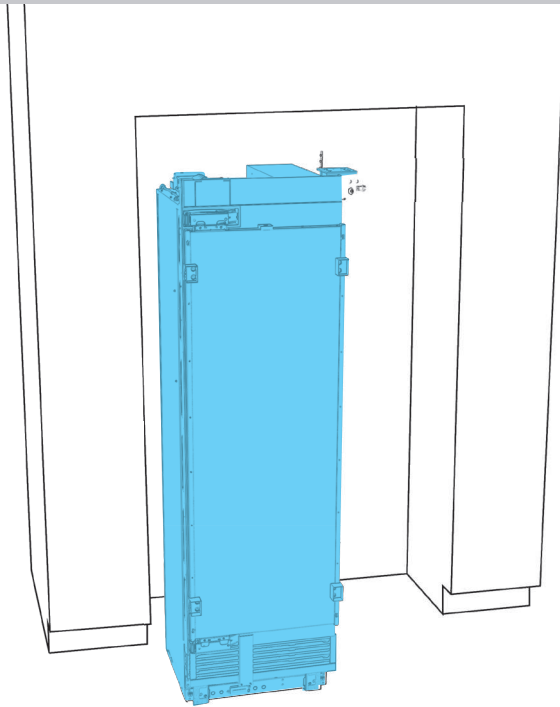

USE TWO PEOPLE. DO NOT OPEN DOORS UNTIL COLUMN IS SECURED.

1.3

EACH COLUMN: REMOVE BOTH WATER FILTER SCREWS.

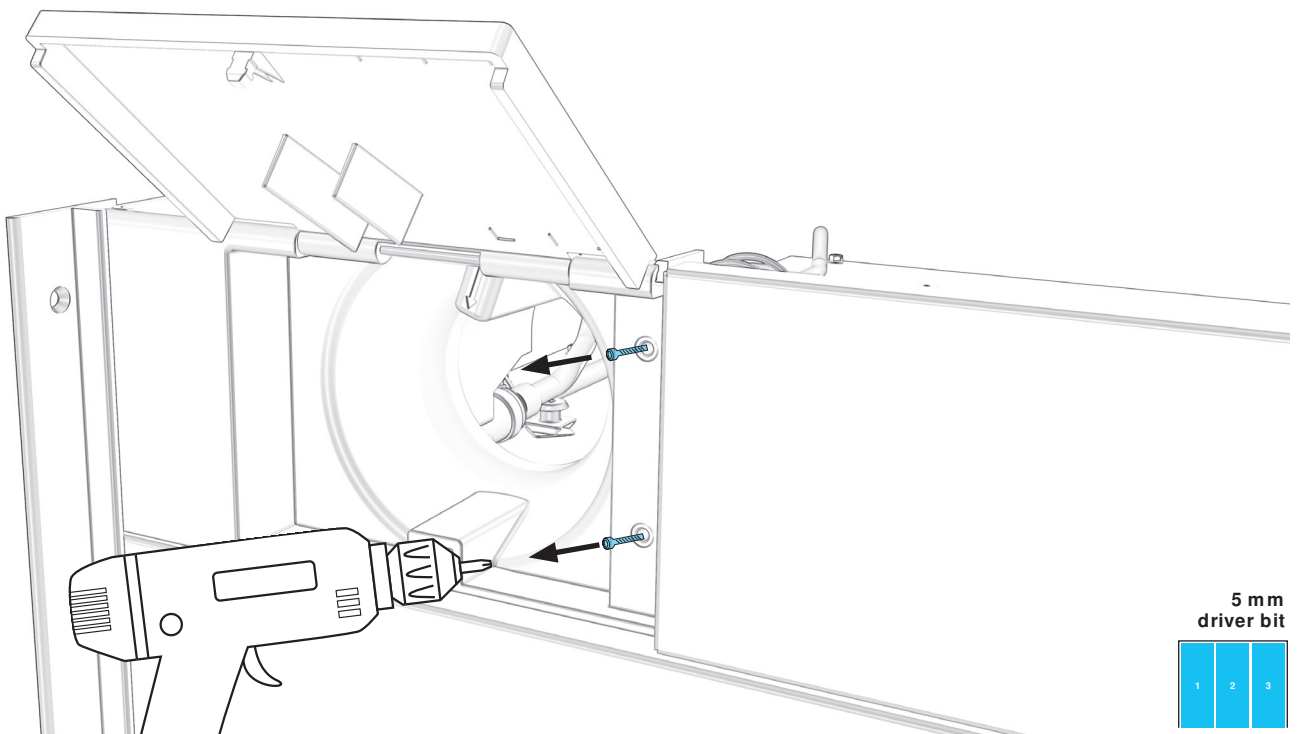

5 mm
driver bit

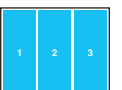

1

PREPARE COLUMNS

1.4

EACH COLUMN: PULLING LEFT, REMOVE FACEPLATE.

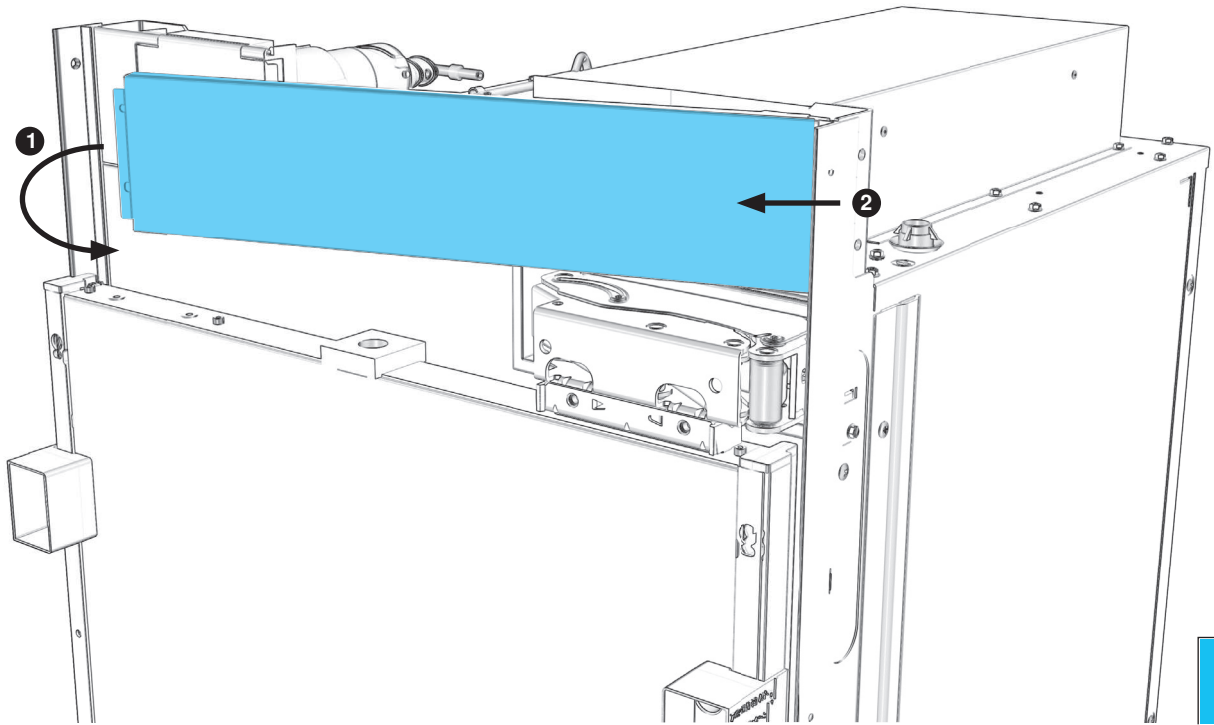

1.5

EACH COLUMN: PULL HOUSING FORCEFULLY RIGHT, REMOVE.

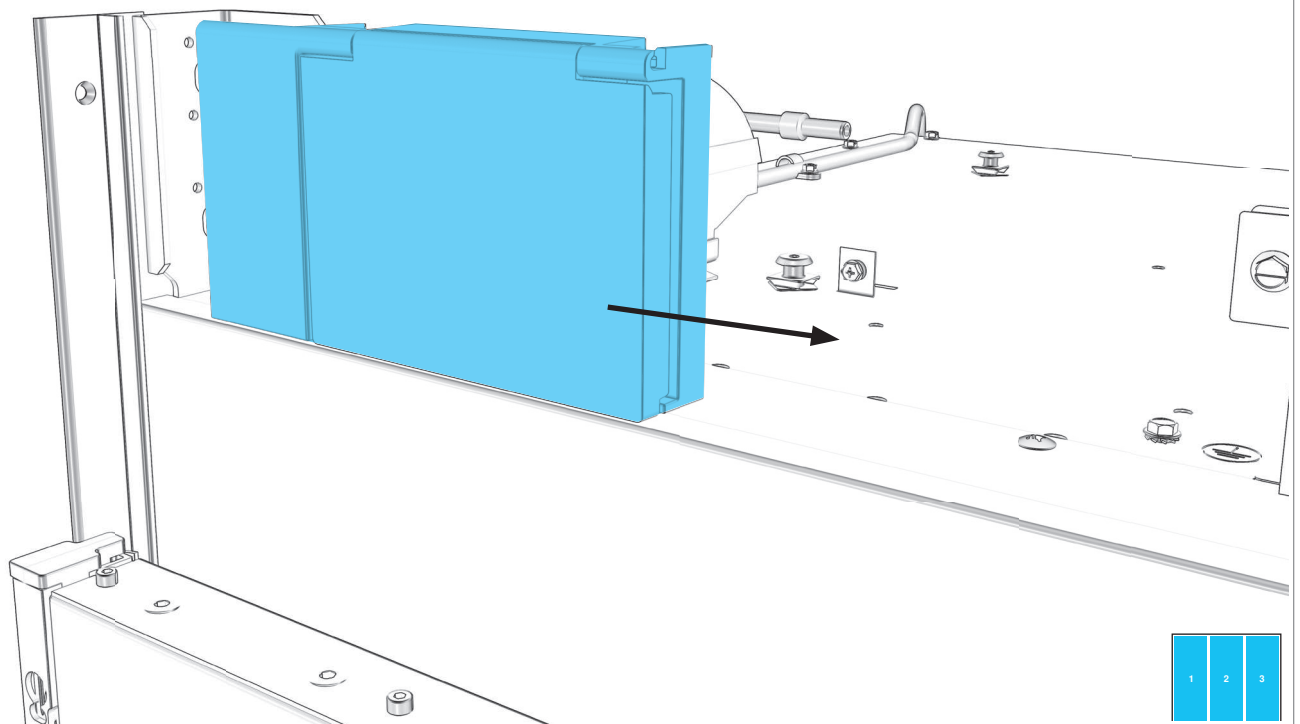

1.6

EACH COLUMN: REMOVE FOUR AIR GRILLE SCREWS.

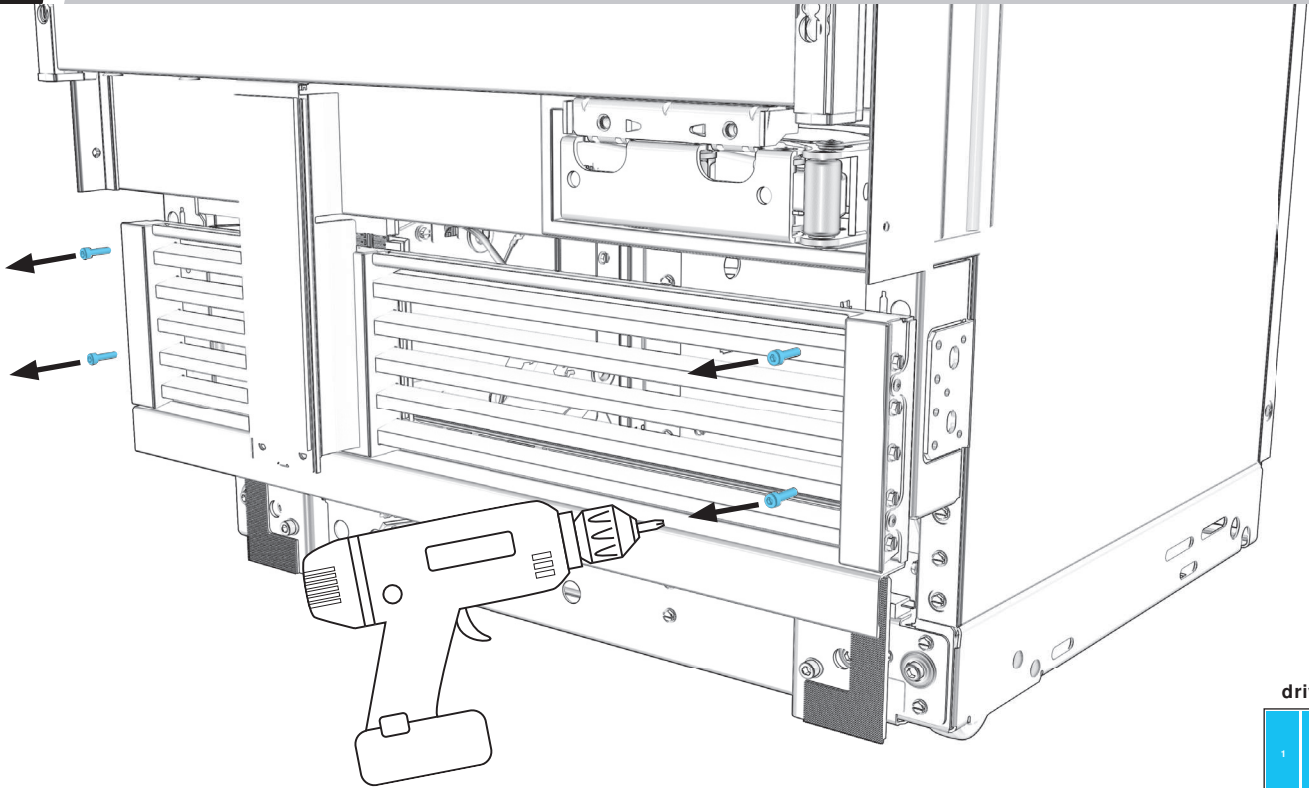

5 mm
driver bit



1.7

EACH COLUMN: REMOVE BASE AIR GRILLE.

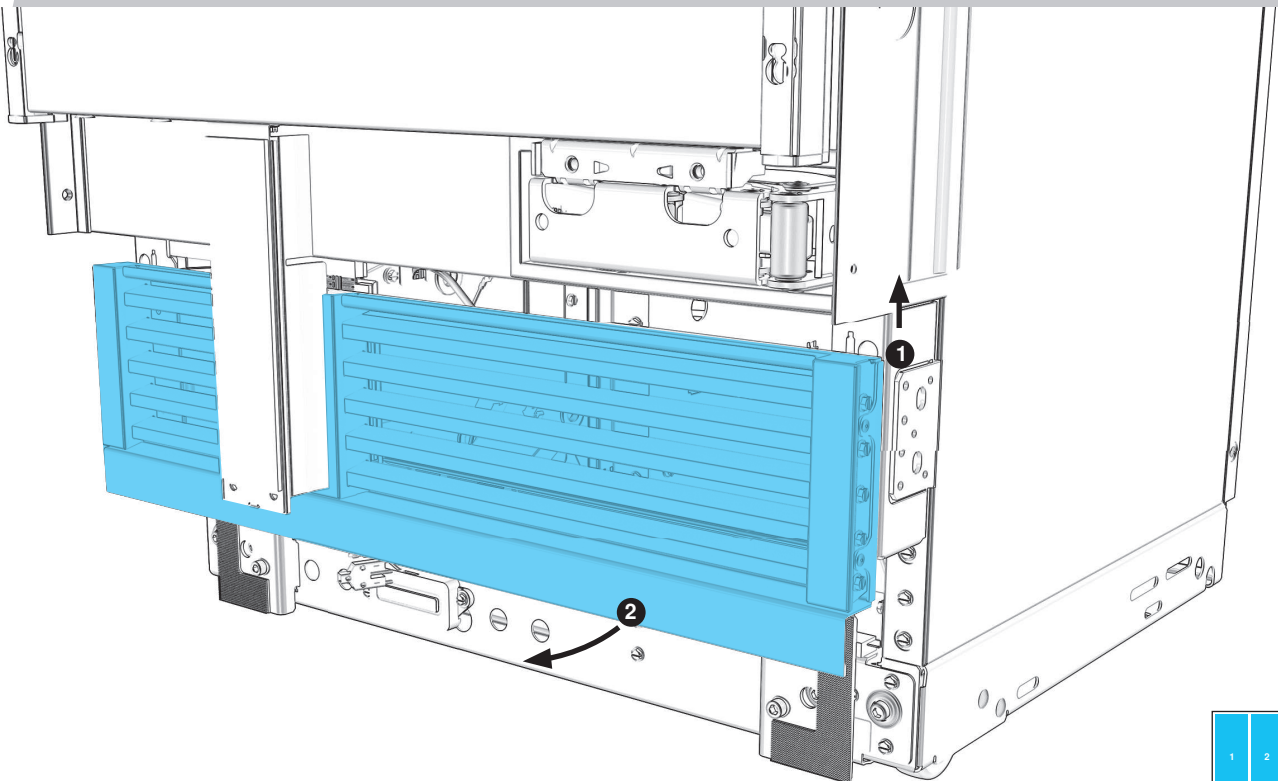

1

PREPARE COLUMNS

1.8

SECOND AND THIRD, IF APPLICABLE COLUMN: INSTALL AIR GRILLE TRIM.

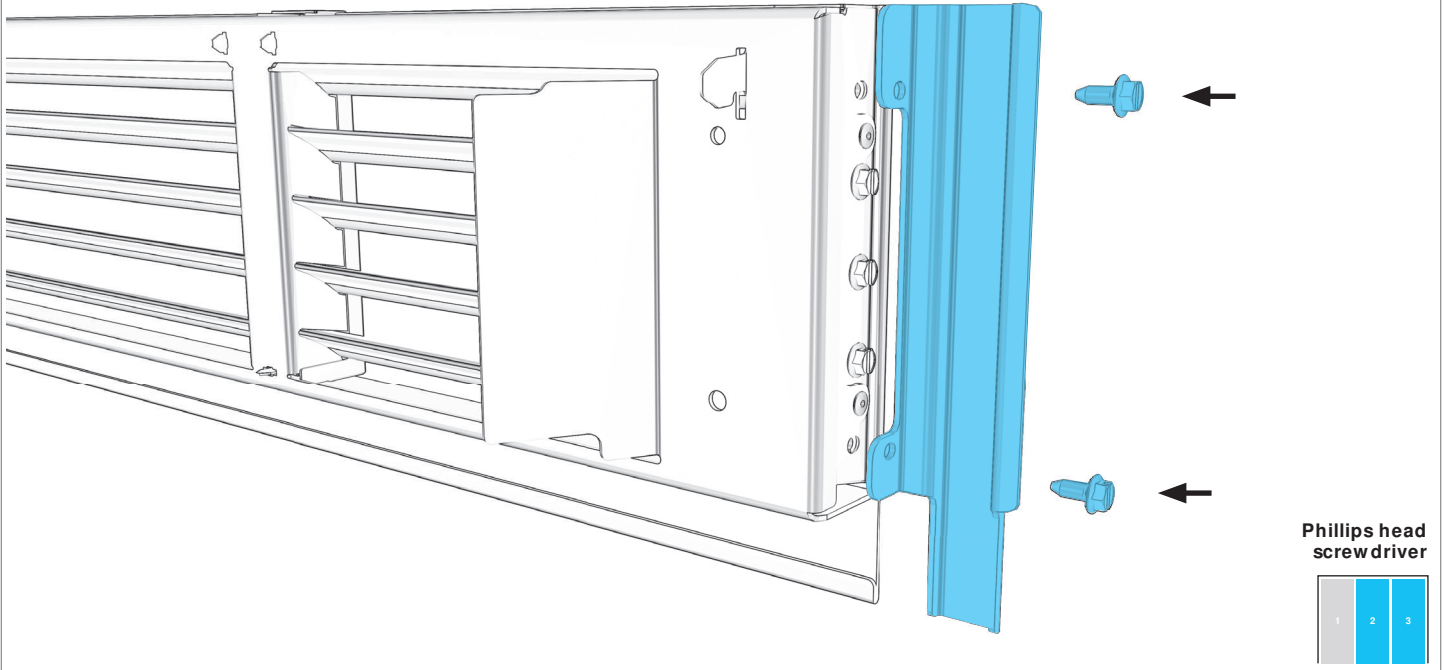

1.9

REMOVE TRIMS BETWEEN COLUMNS.

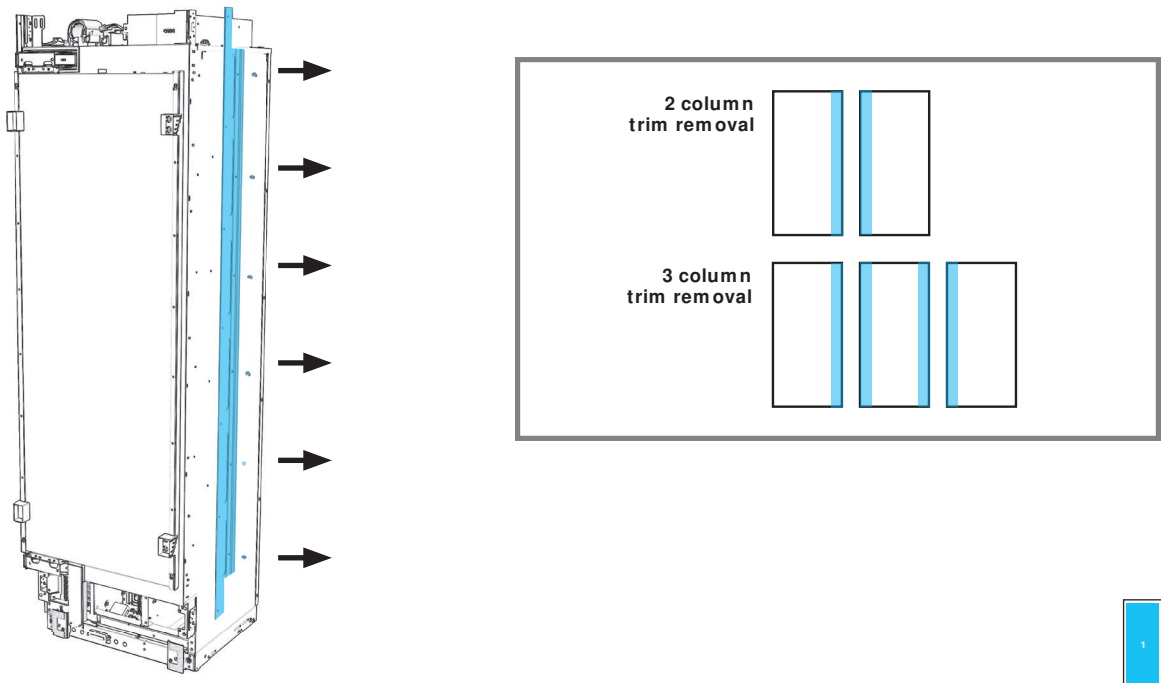

LEAVE TRIMS IN PLACE ON FURNITURE SIDES.

1.10 FIRST COLUMN: INSTALL SPACER.

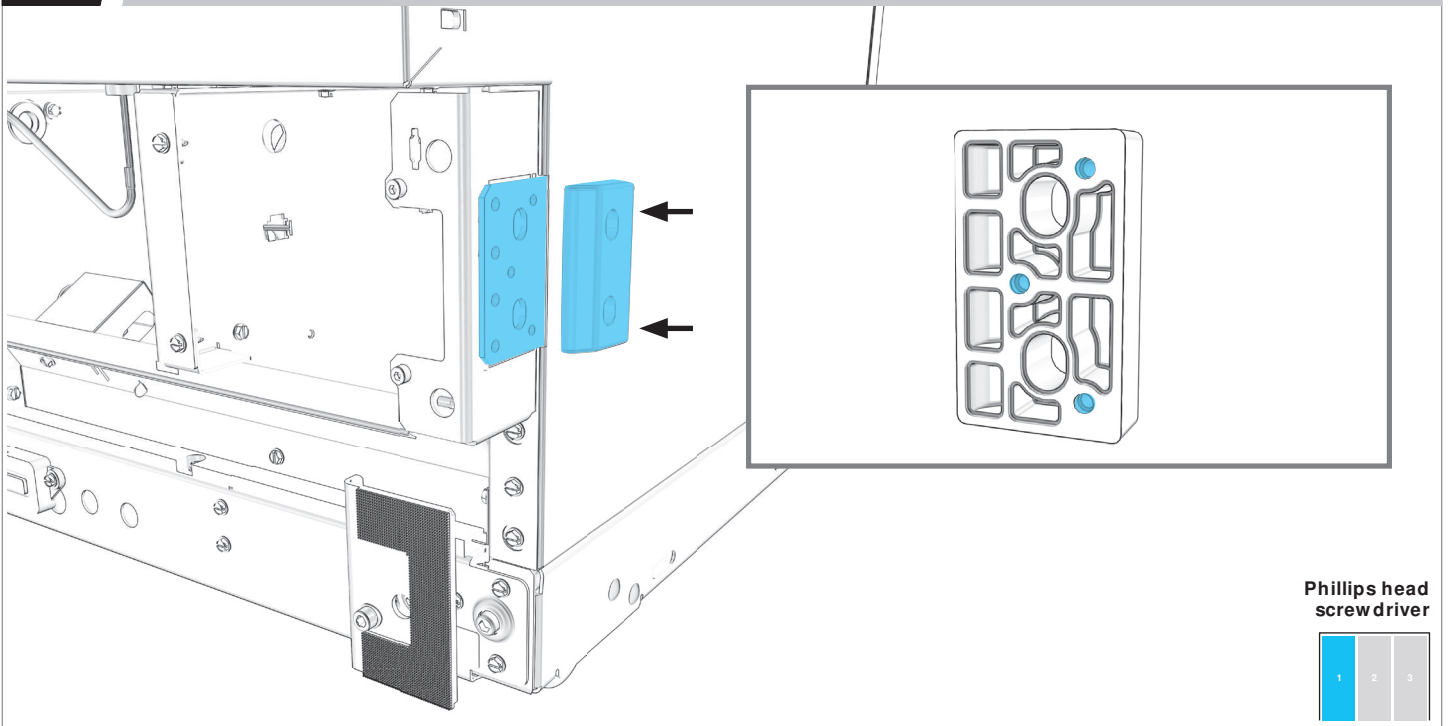

★ MAKE SURE NARROW EDGE FACES OUT.

1.11 IF INSTALLING THREE COLUMNS: REPEAT 1.10 ON SECOND COLUMN.

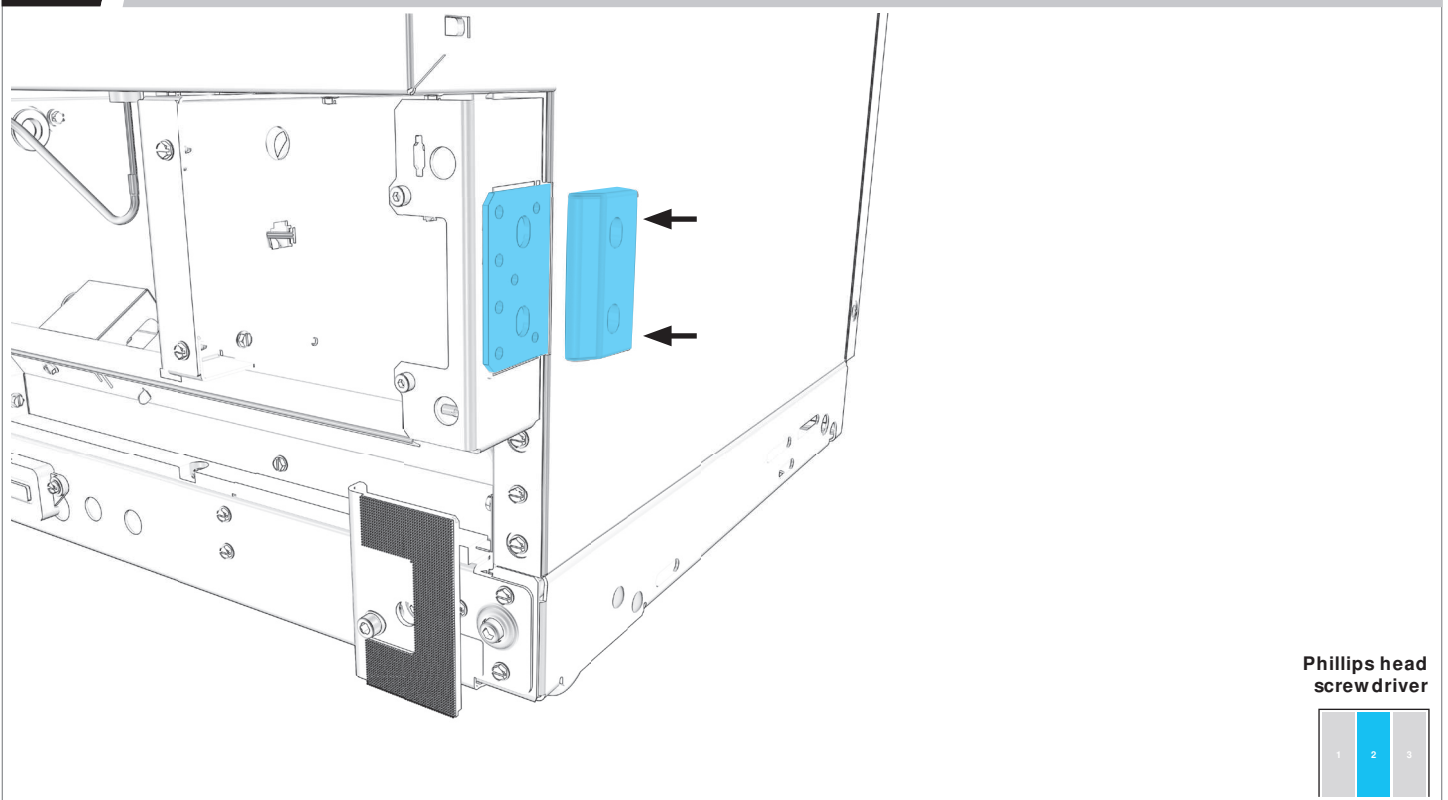

P R E P A R E
2
JOIN KIT

2.1 FIRST COLUMN: ALIGN AND ADHERE HEATER.

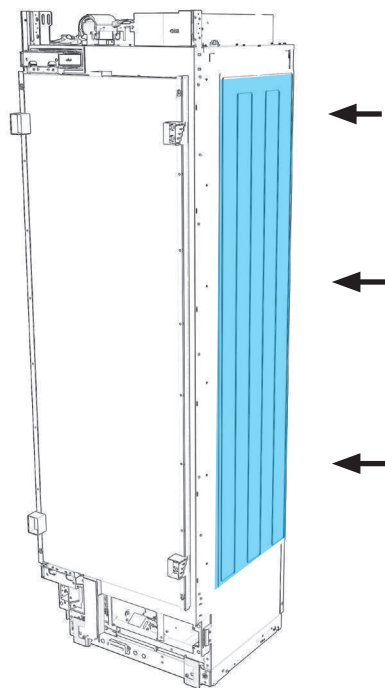

2.2 PLUG HEATER INTO COLUMN.

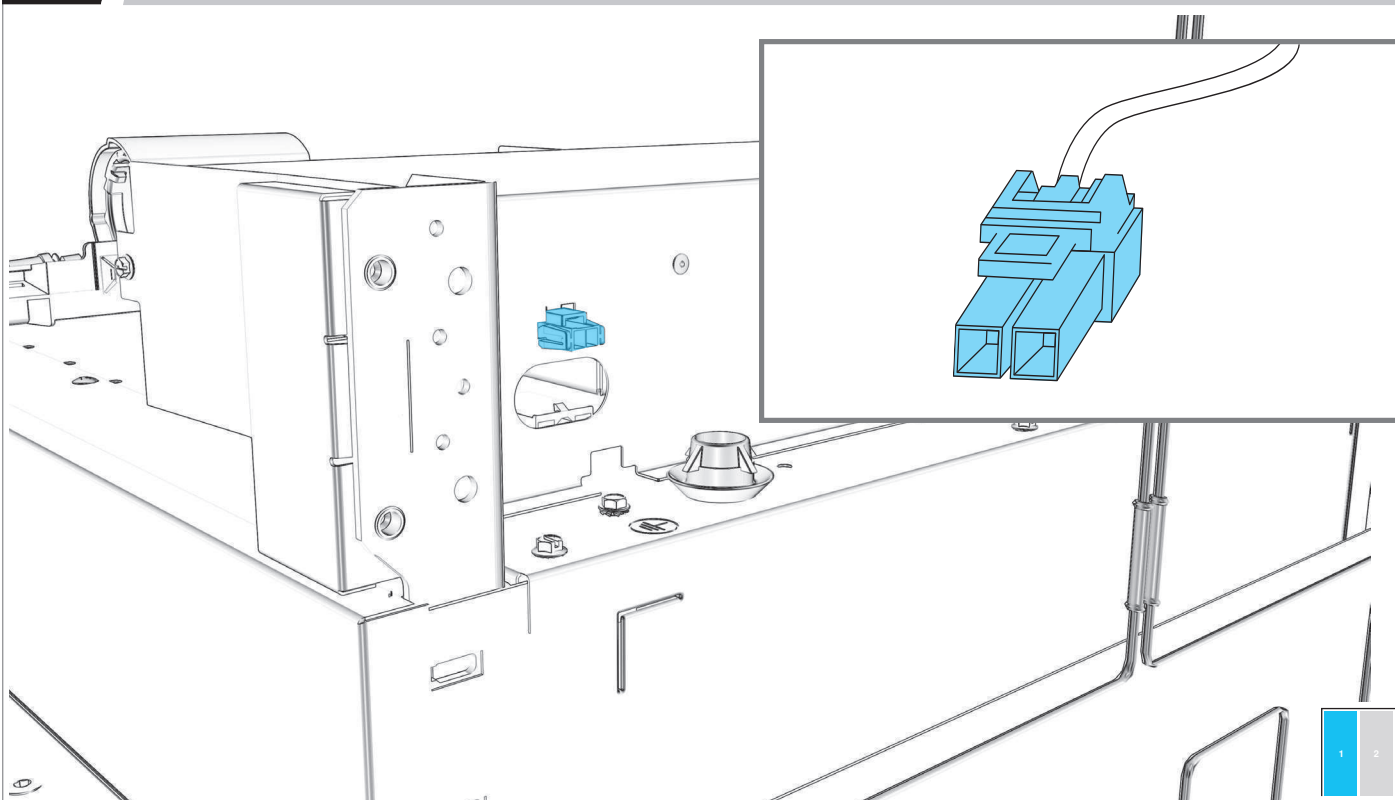

2

PREPARE JOIN KIT

2.3

REPEAT 2.1 2.2 ON SECOND COLUMN.

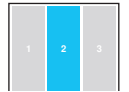
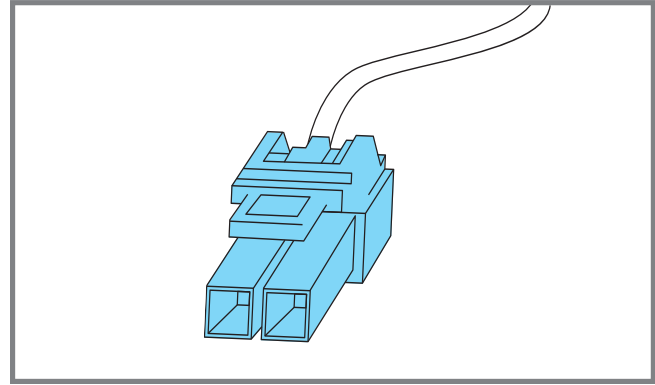
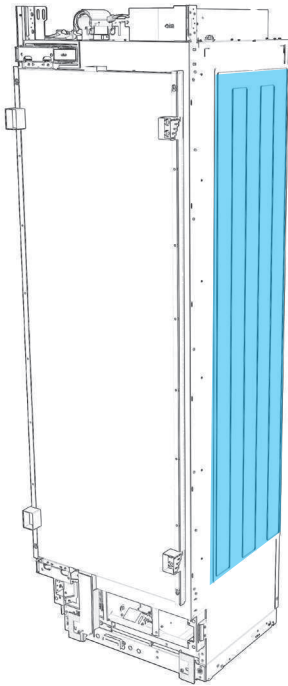

2.4

FIRST COLUMN: INSTALL "L" JOIN TRIM.

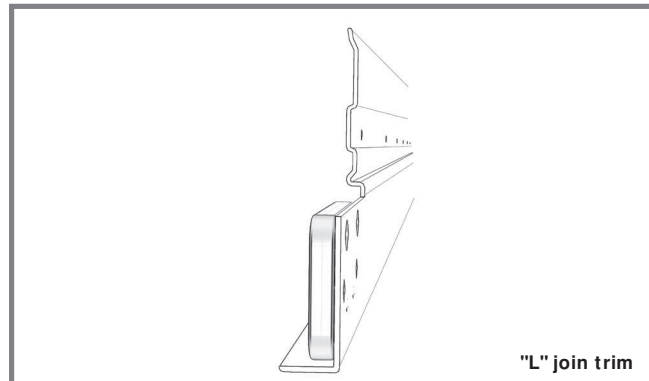
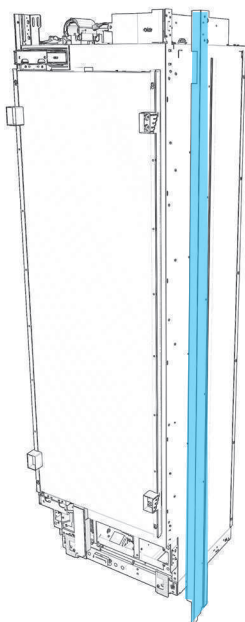

Phillips head
screw driver



2.5

SECOND COLUMN: INSTALL "HOOK" JOIN TRIM.

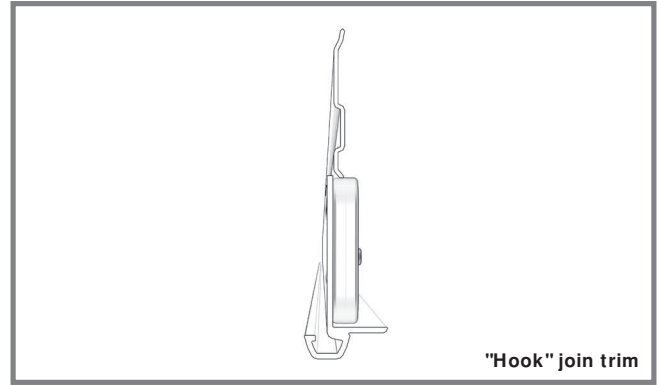
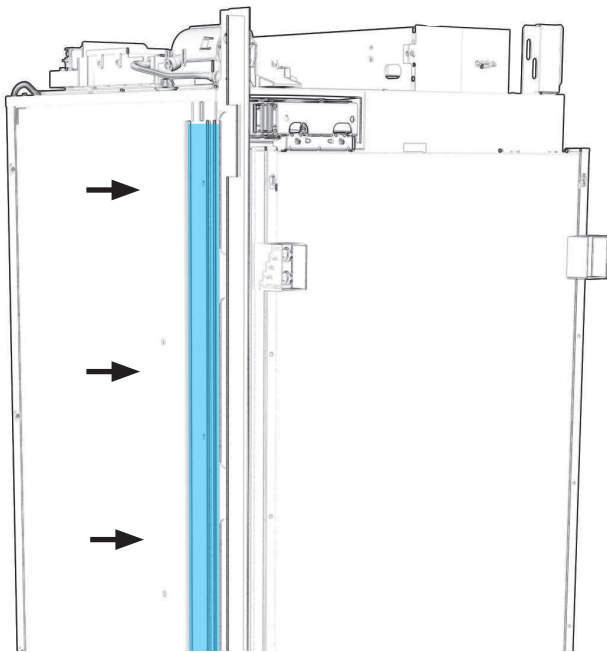

Phillips head
screw driver



2.6

IF INSTALLING THREE COLUMNS: INSTALL "L" JOIN TRIM ON SECOND COLUMN.

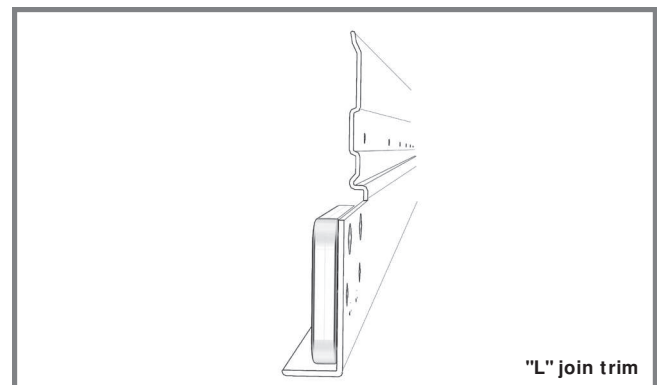
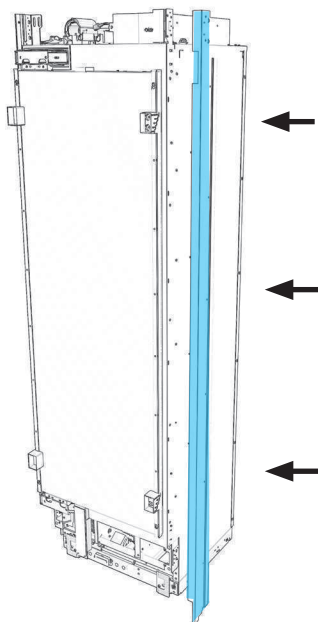

Phillips head
screw driver

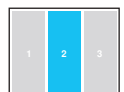

2

PREPARE JOIN KIT

2.7

IF INSTALLING THREE COLUMNS: INSTALL "HOOK" JOIN TRIM ON THIRD COLUMN.

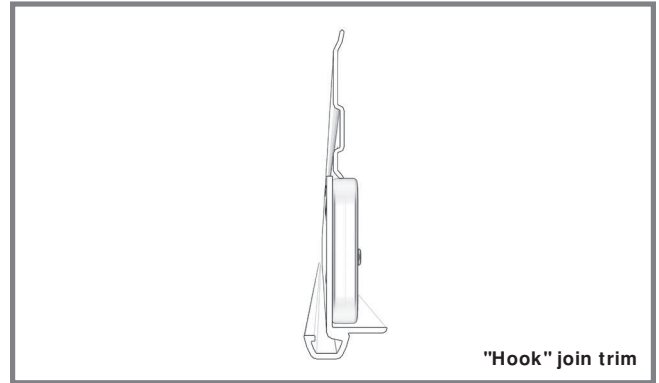
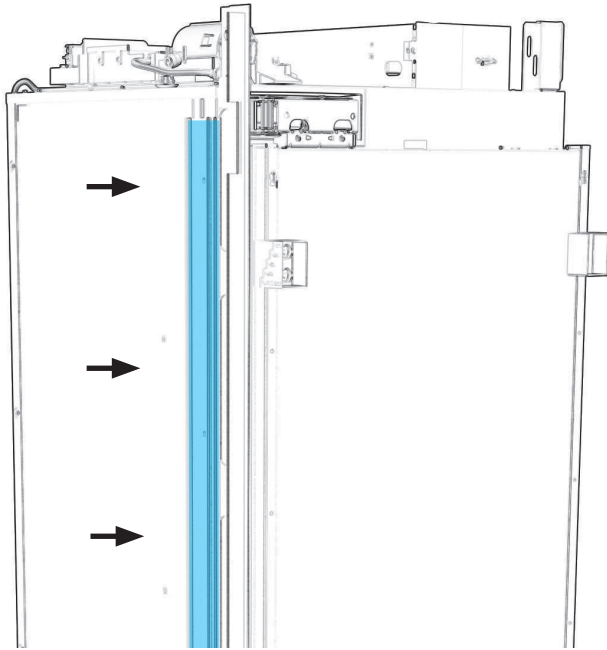

Phillips head
screw driver



P R E P A R E

POSITIONING BRACKET

3

PREPARE POSITIONING BRACKET

3.1 FIRST COLUMN: SLIDE MOUNT INTO INSTALLATION SLOT.

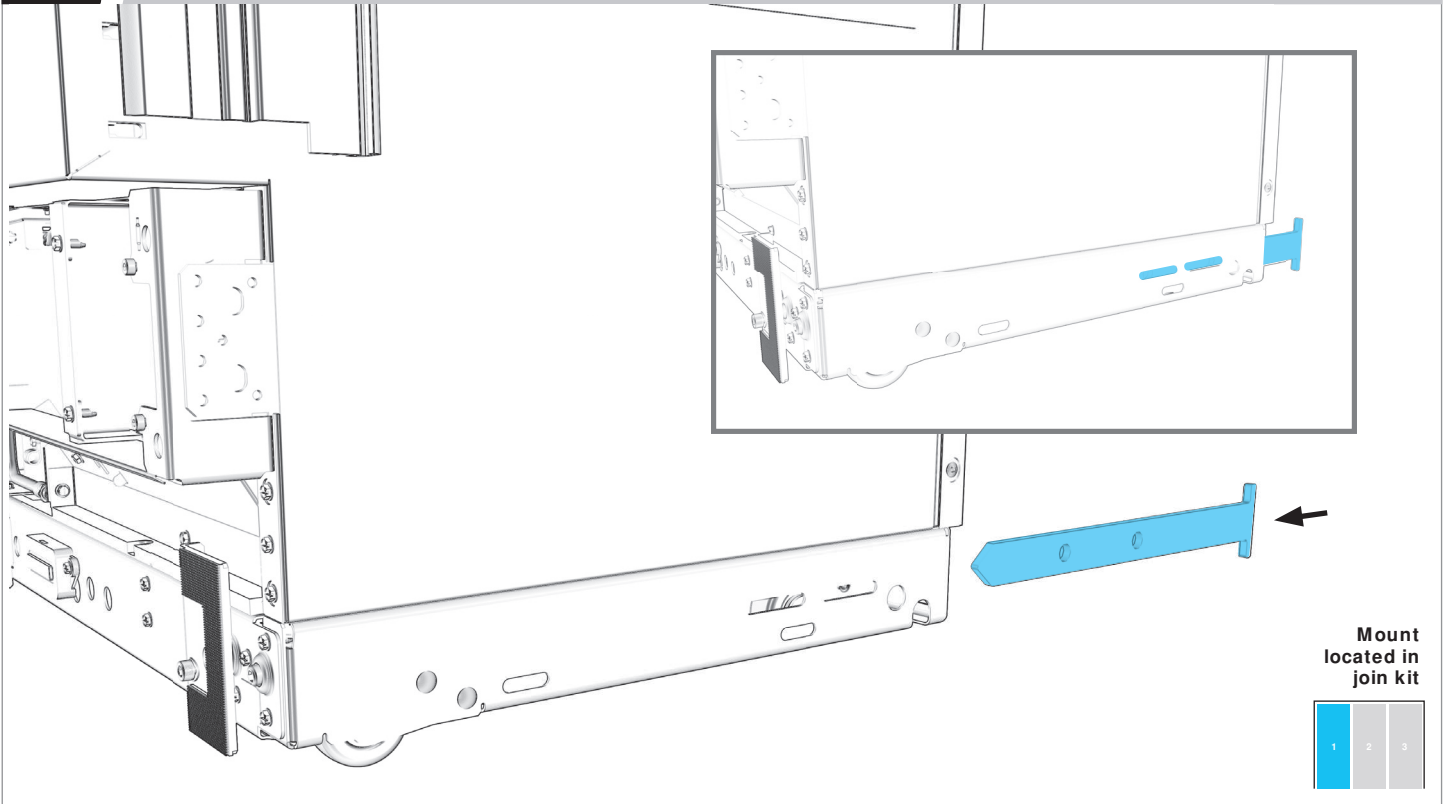

3.2 USE SCREW DRIVER TO ENSURE HOLES ARE ALIGNED.

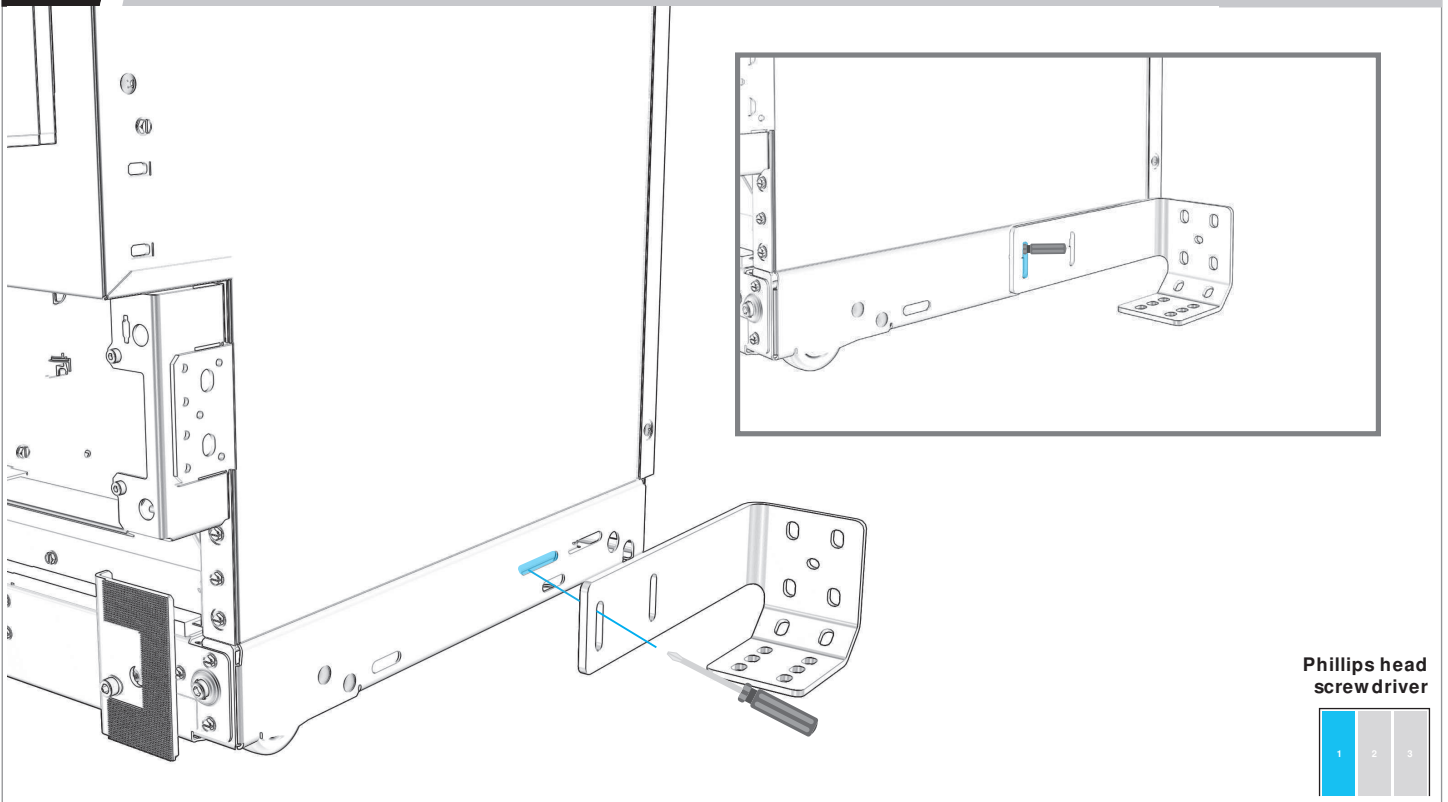

3.4 LOOSELY ATTACH POSITIONING BRACKET TO MOUNT.

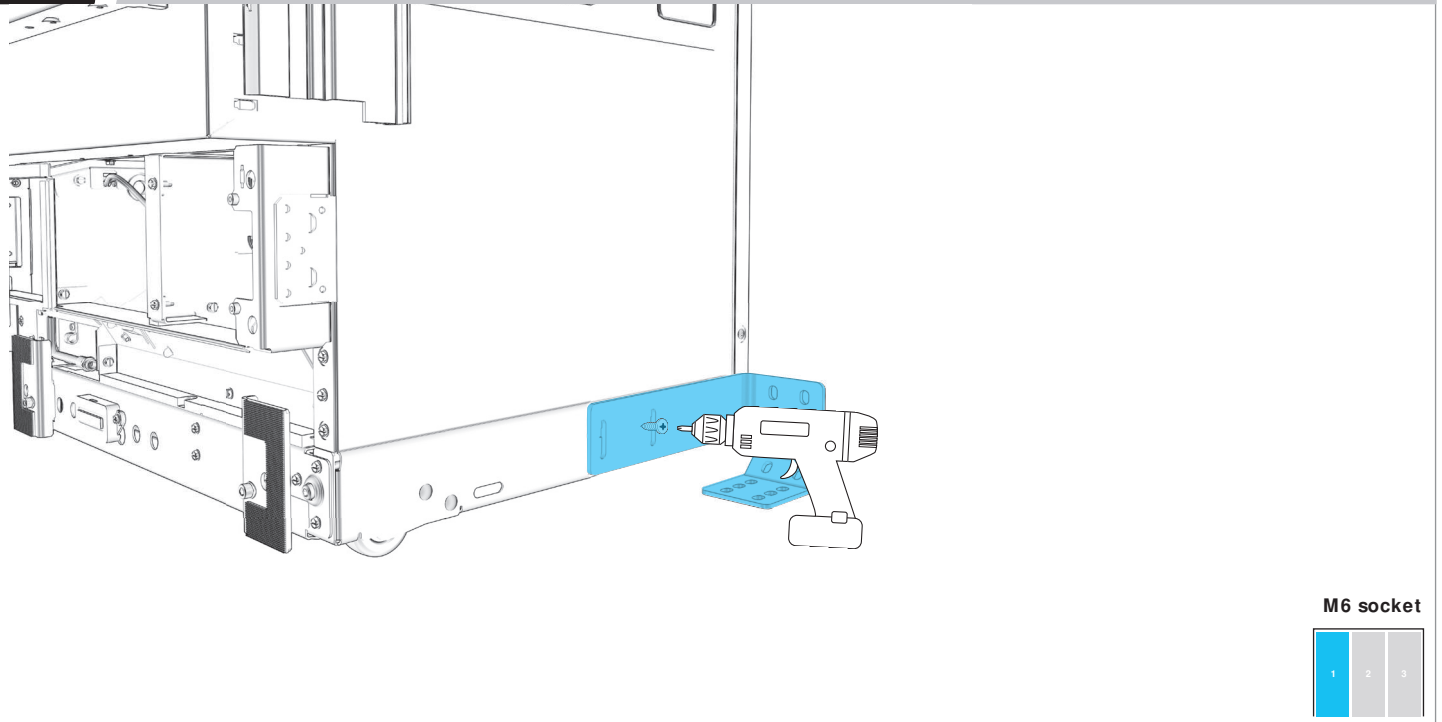

M6 socket



★ FINAL PLACEMENT DETERMINED ONCE COLUMNS ARE FULLY RAISED.

3.5 IF INSTALLING A THIRD COLUMN: REPEAT 3.1 3.4 ON SECOND COLUMN.

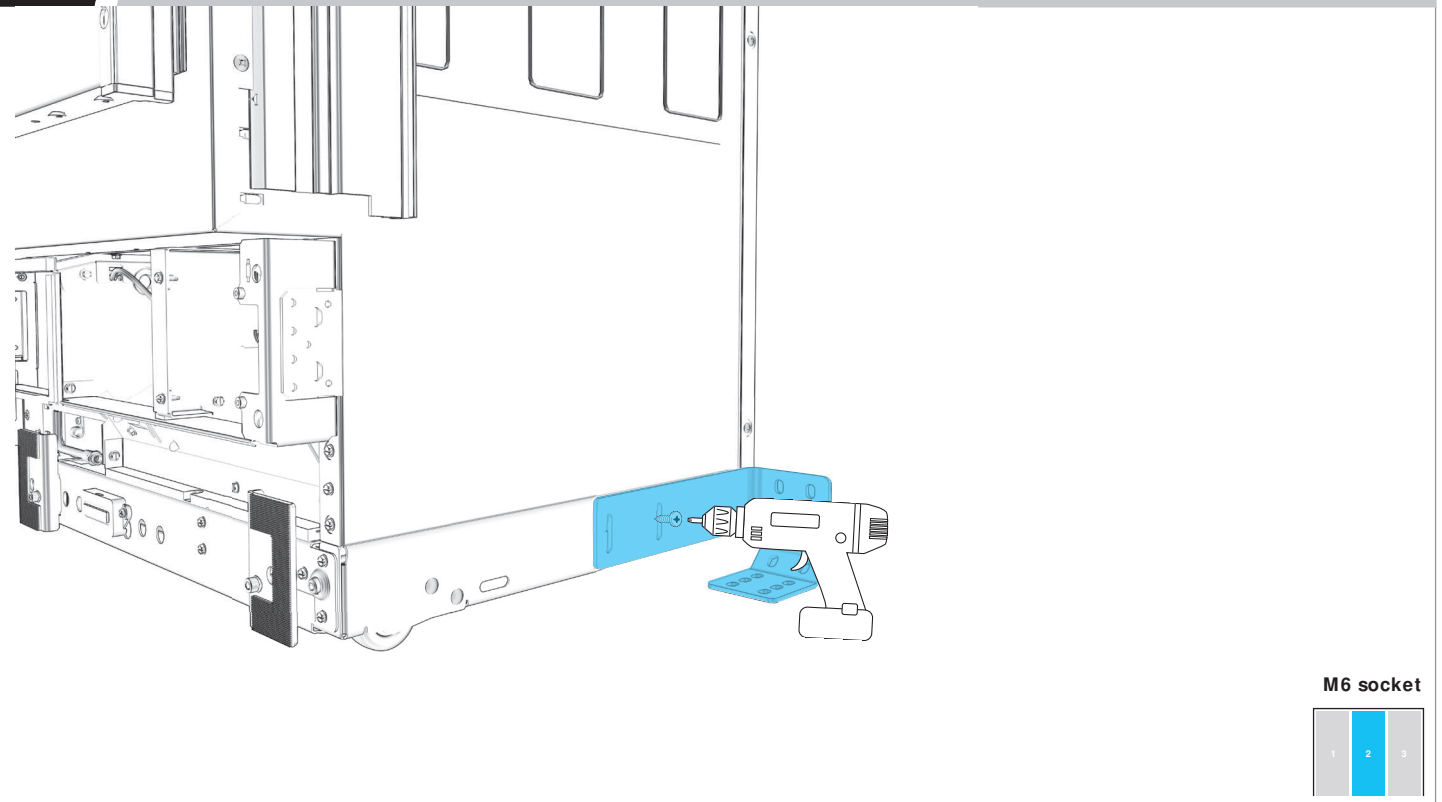

M6 socket



B A D A S S
BRACKET INSTALLATION

4.1

MARK LINE AT FIRST COLUMN'S WIDTH FROM LEFT SIDE FACE FRAME.

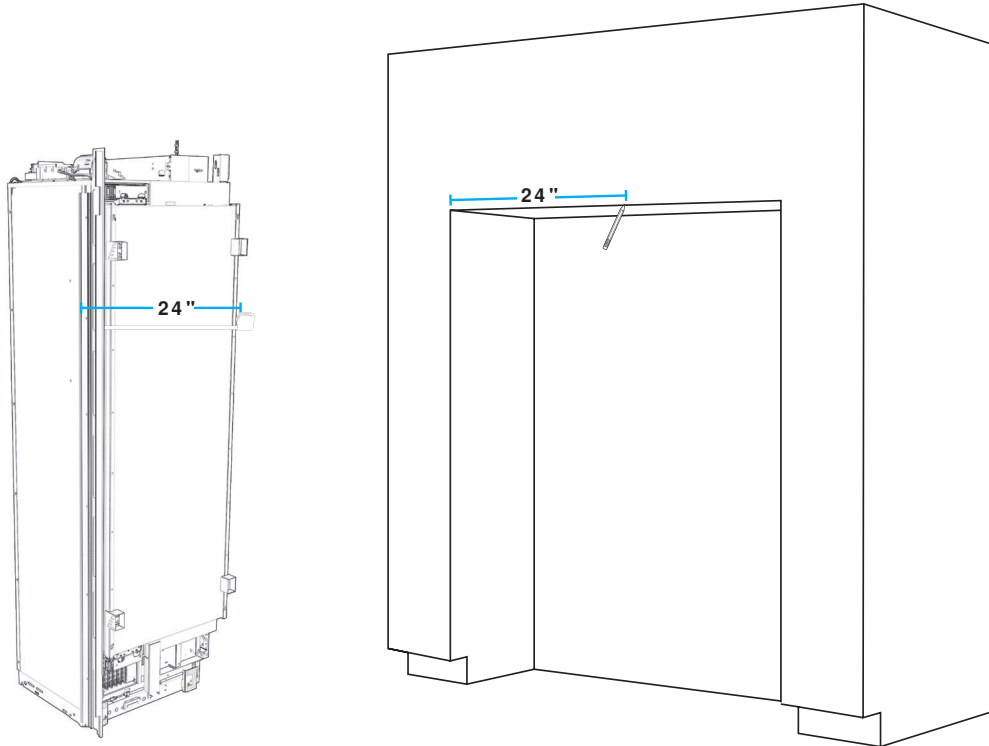

4.2

WITH CARPENTER SQUARE, DRAW LINE PERPENDICULAR TO FACE FRAME.

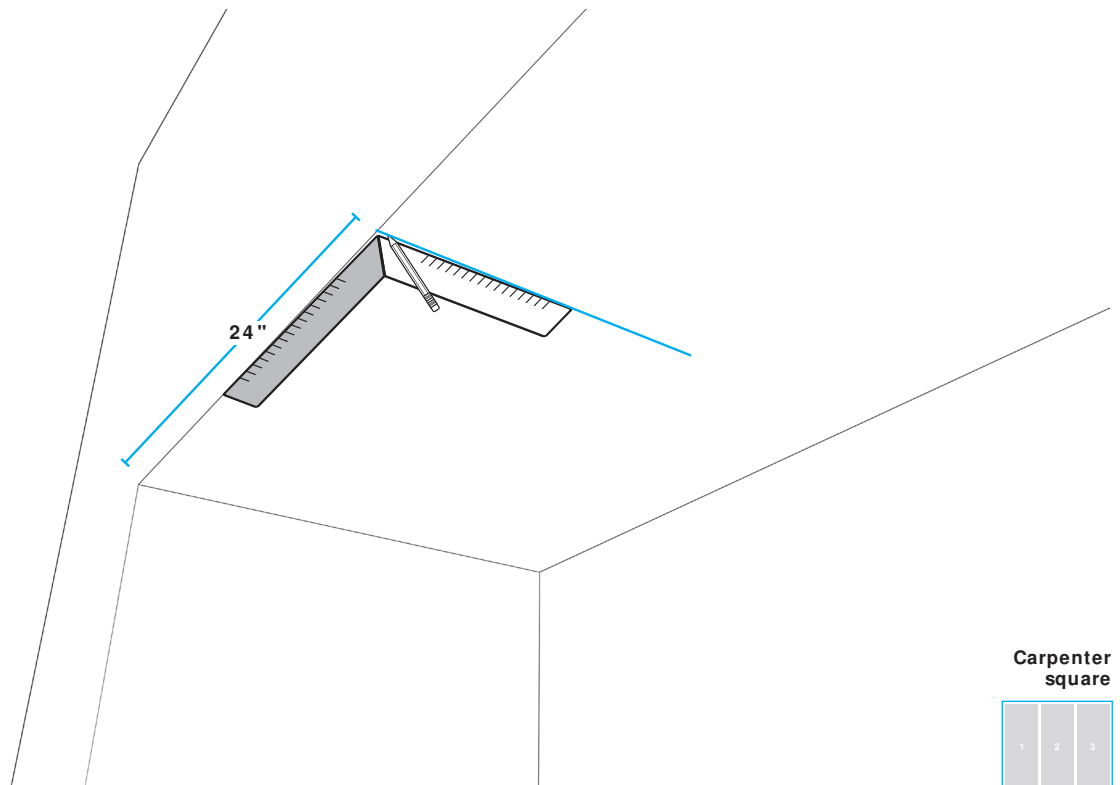

Carpenter
square



4

BADASS BRACKET INSTALLATION

4.3

ALIGN BRACKET TEMPLATE CENTER SLOTS WITH WIDTH LINE.

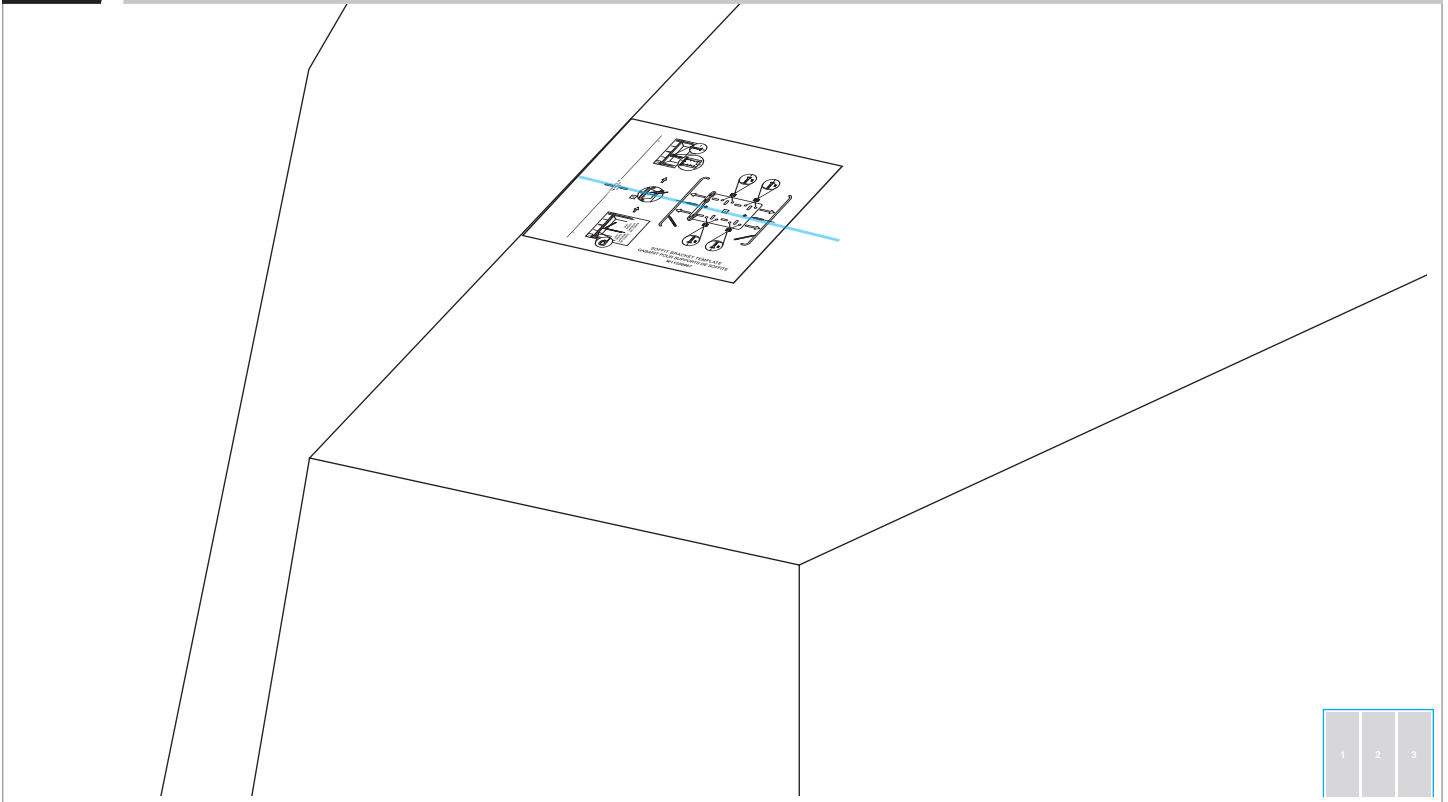

4.4

ALIGN THE PREVIOUSLY SELECTED DOOR STYLE LINE WITH CABINET FACE.

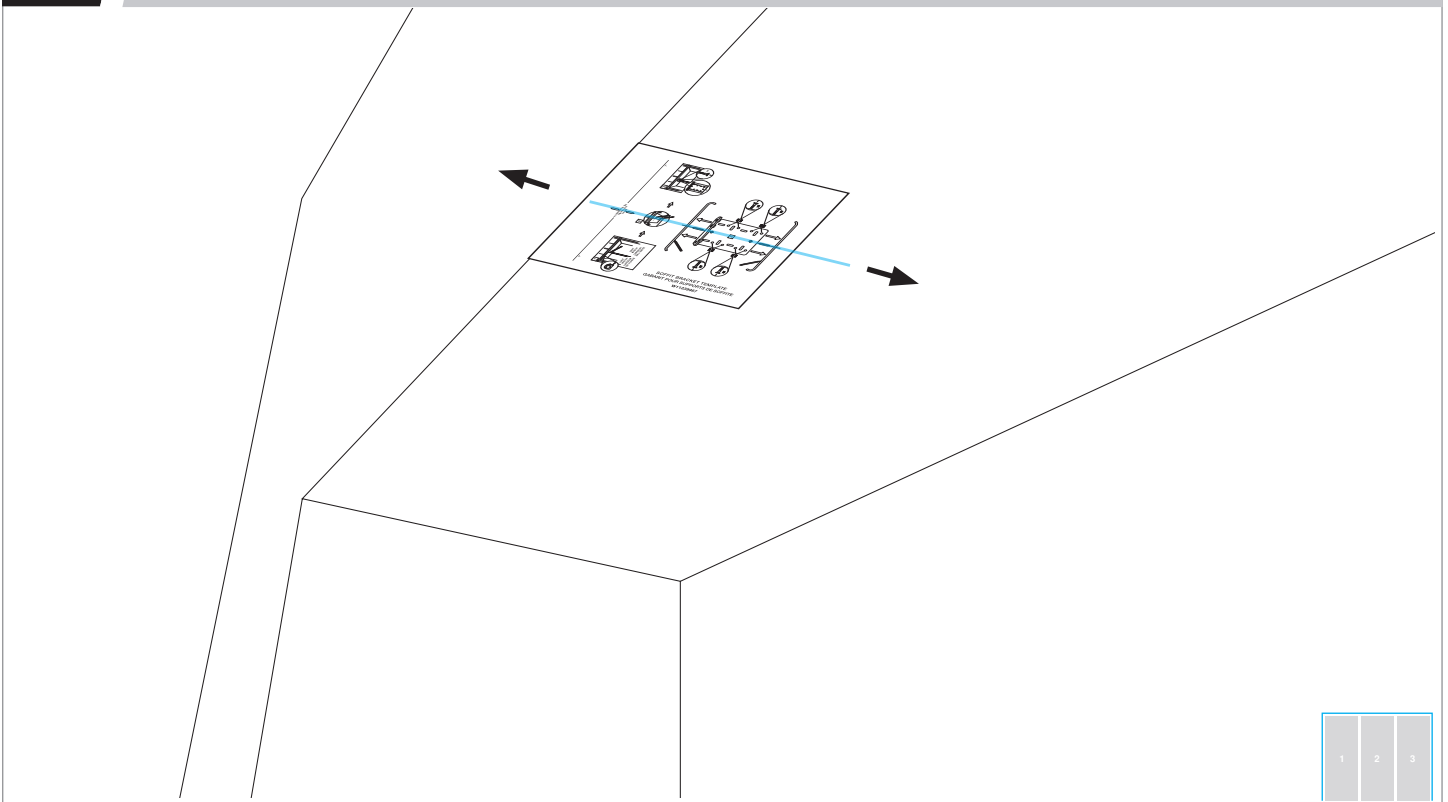

4.5

MARK TWO LINES.

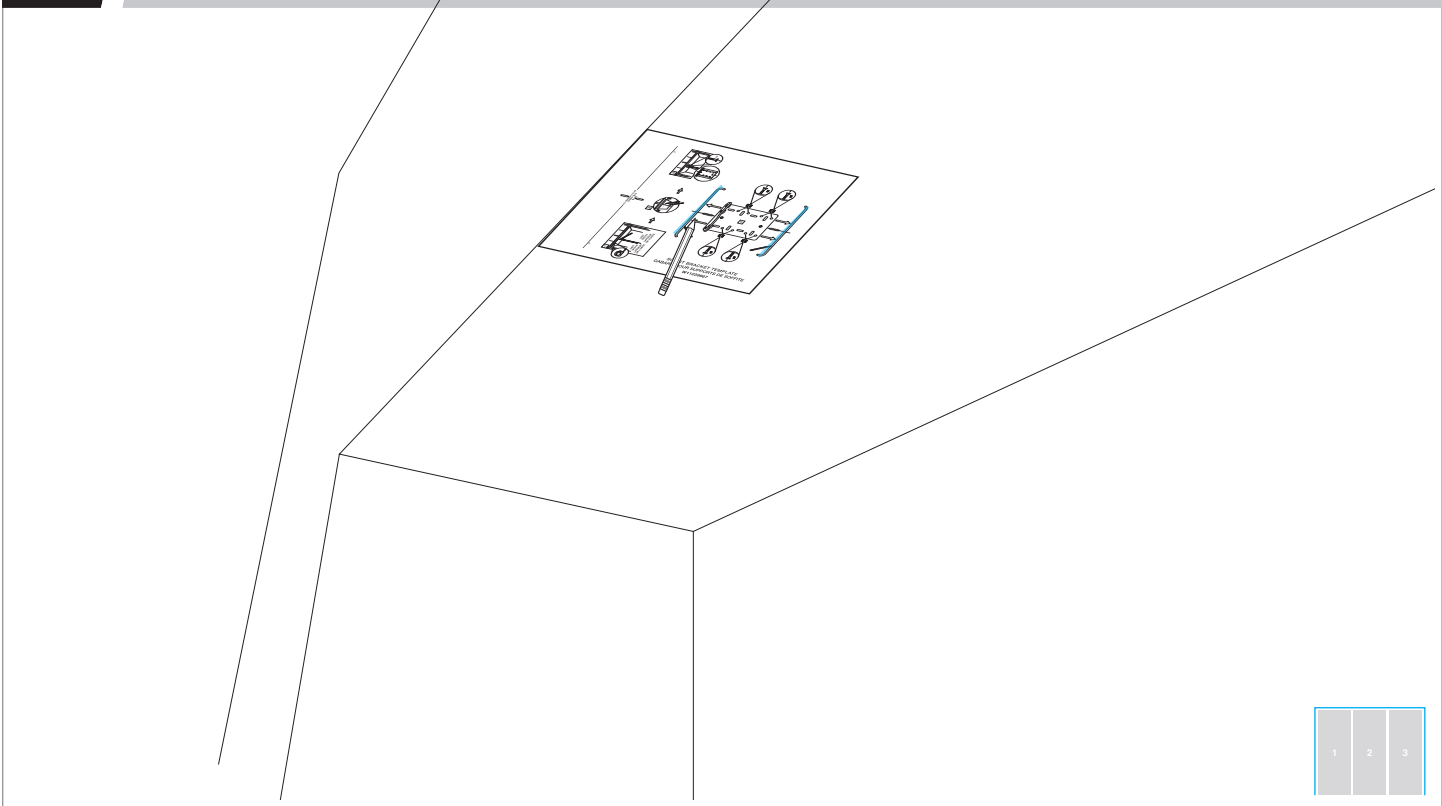

4.6

ALIGN BRACKET.

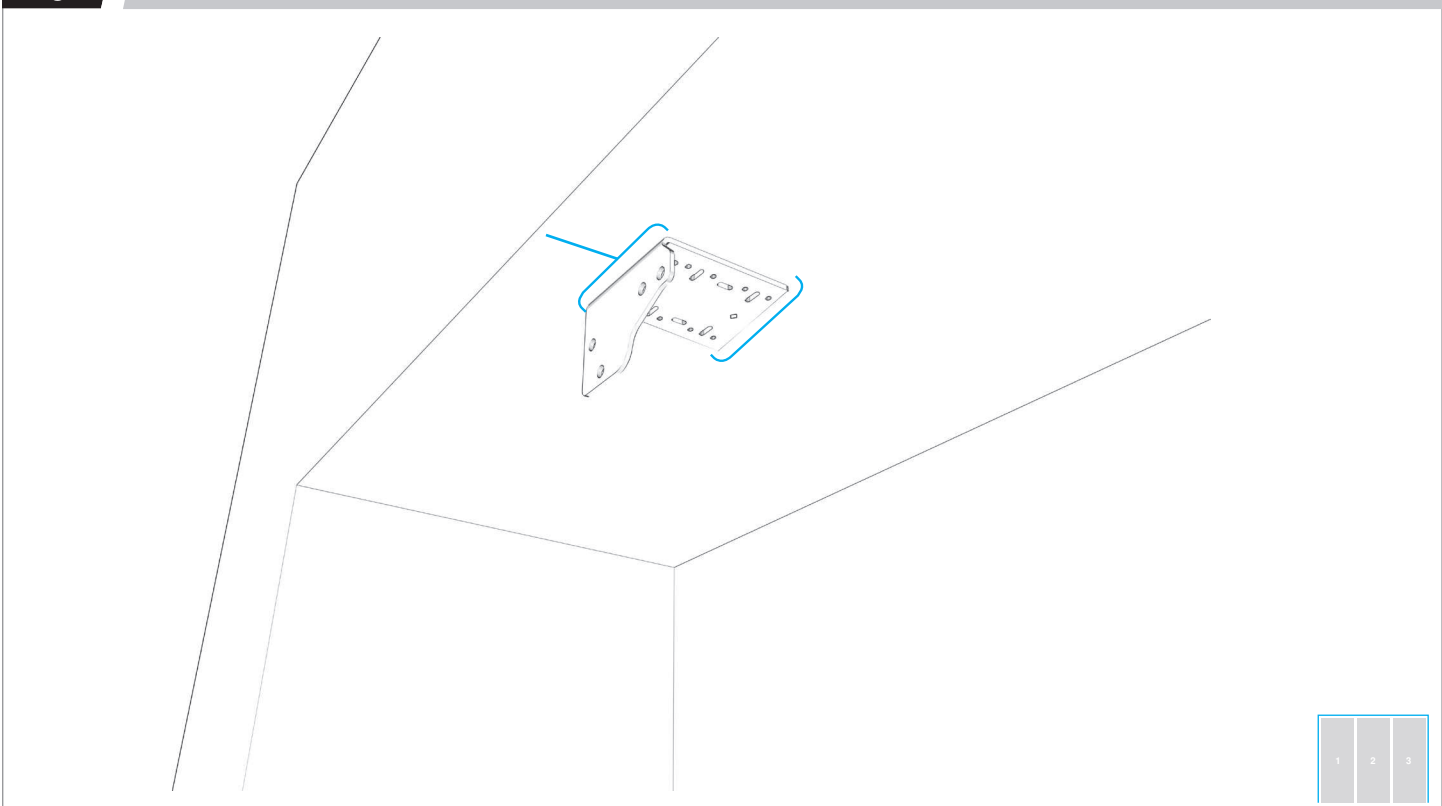

4

BADASS BRACKET INSTALLATION

4.7

ALIGN POINTS OF DIAMOND SHAPED HOLES WITH WIDTH LINE.

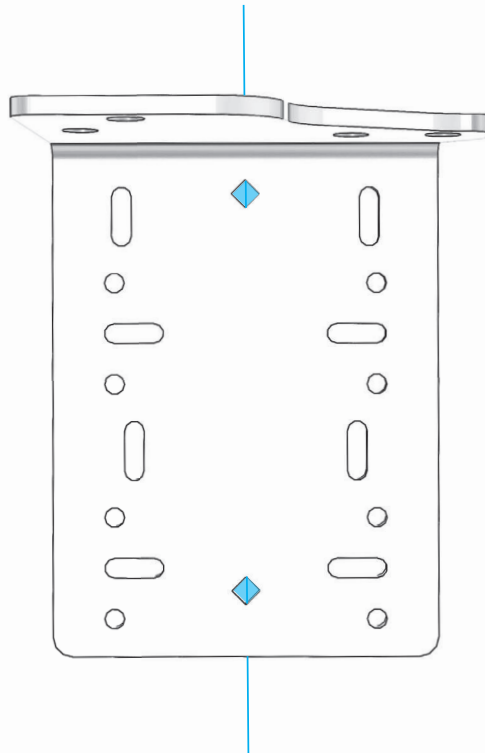

4.8

LOOSELY ATTACH BRACKET TO SOFFIT.

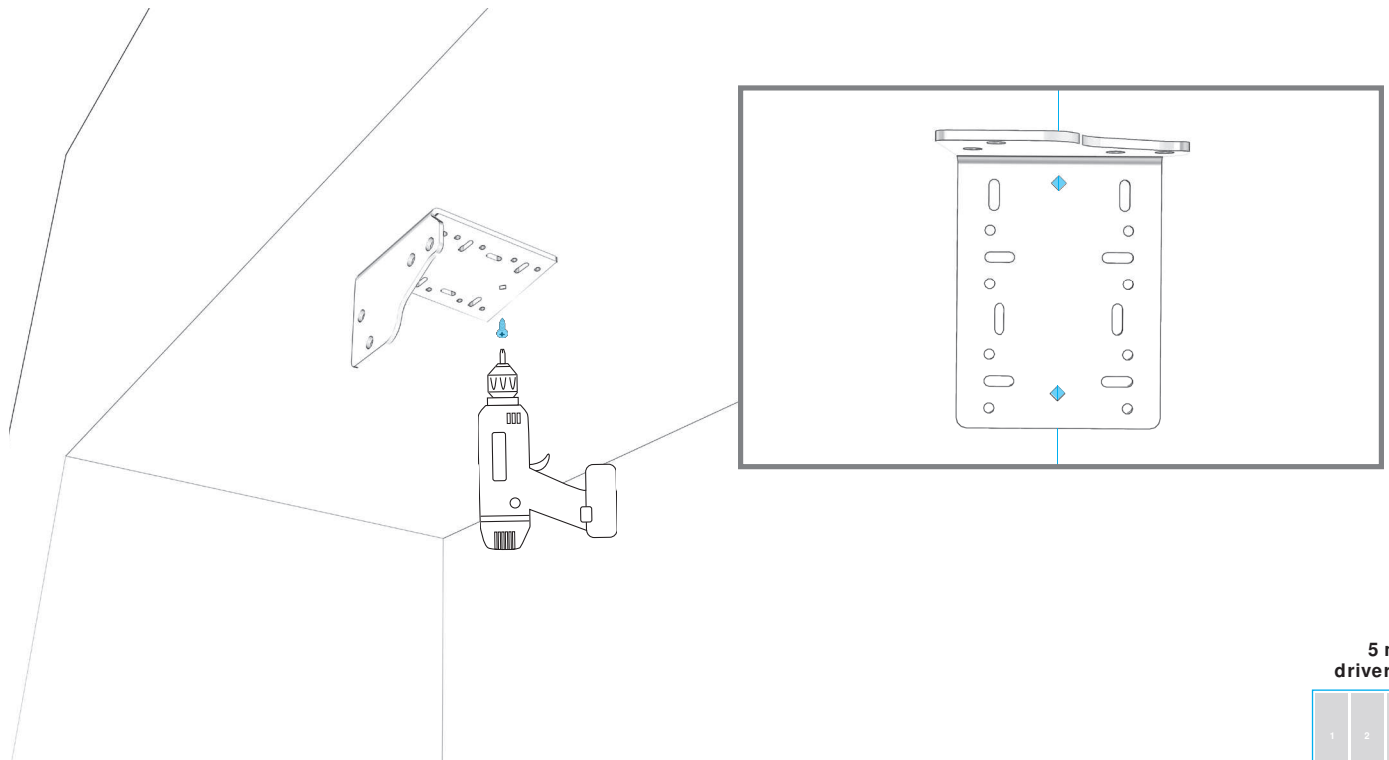

5 mm
driver bit



4.9

REALIGN BRACKET EDGES WITH ALIGNMENT LINES.

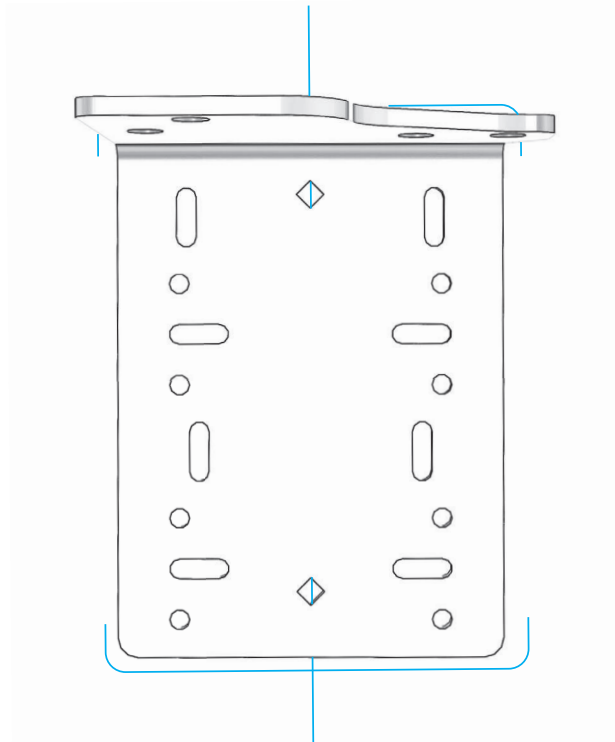

4.10

TIGHTEN 8 SCREWS.

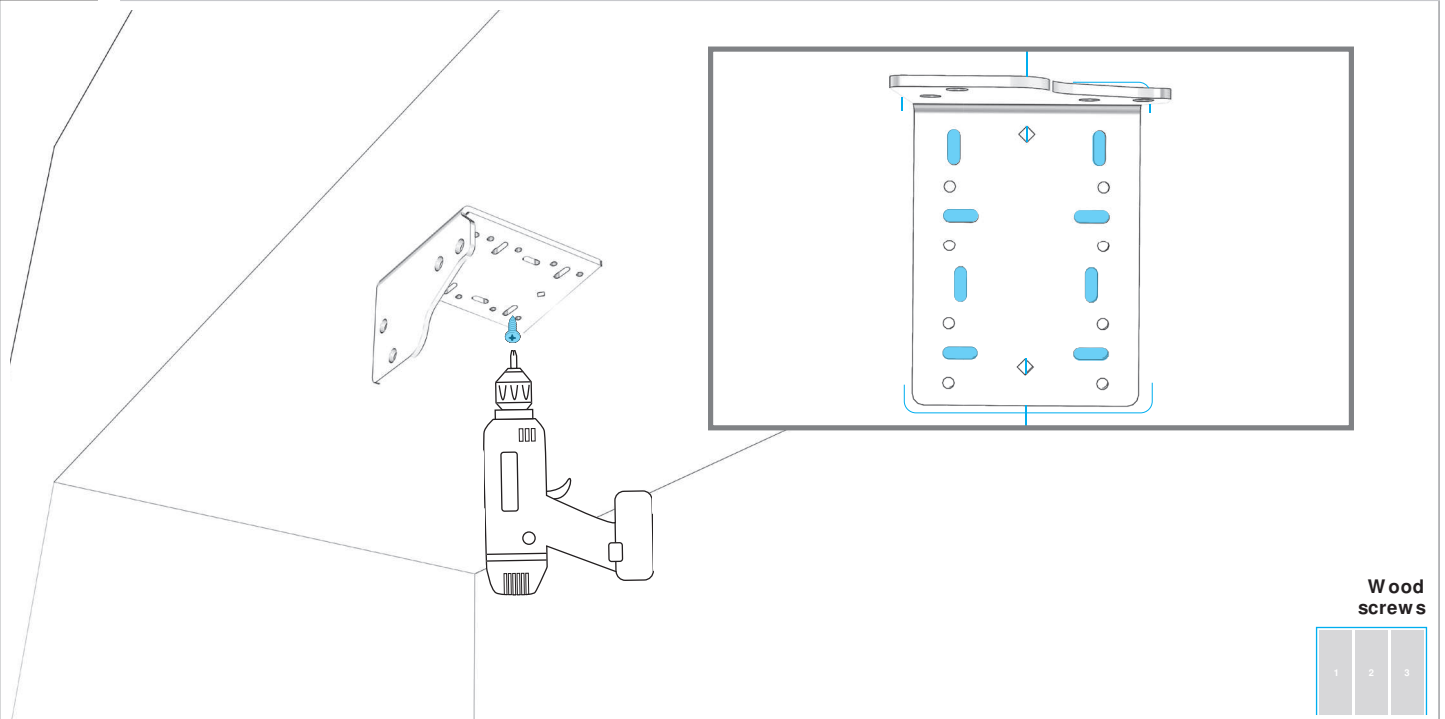

Wood
screws



USE WOOD SCREWS OF AN APPROPRIATE LENGTH

4

BADASS BRACKET INSTALLATION

4.11

SECURE BRACKET TO CABINET THROUGH ROUND HOLES.

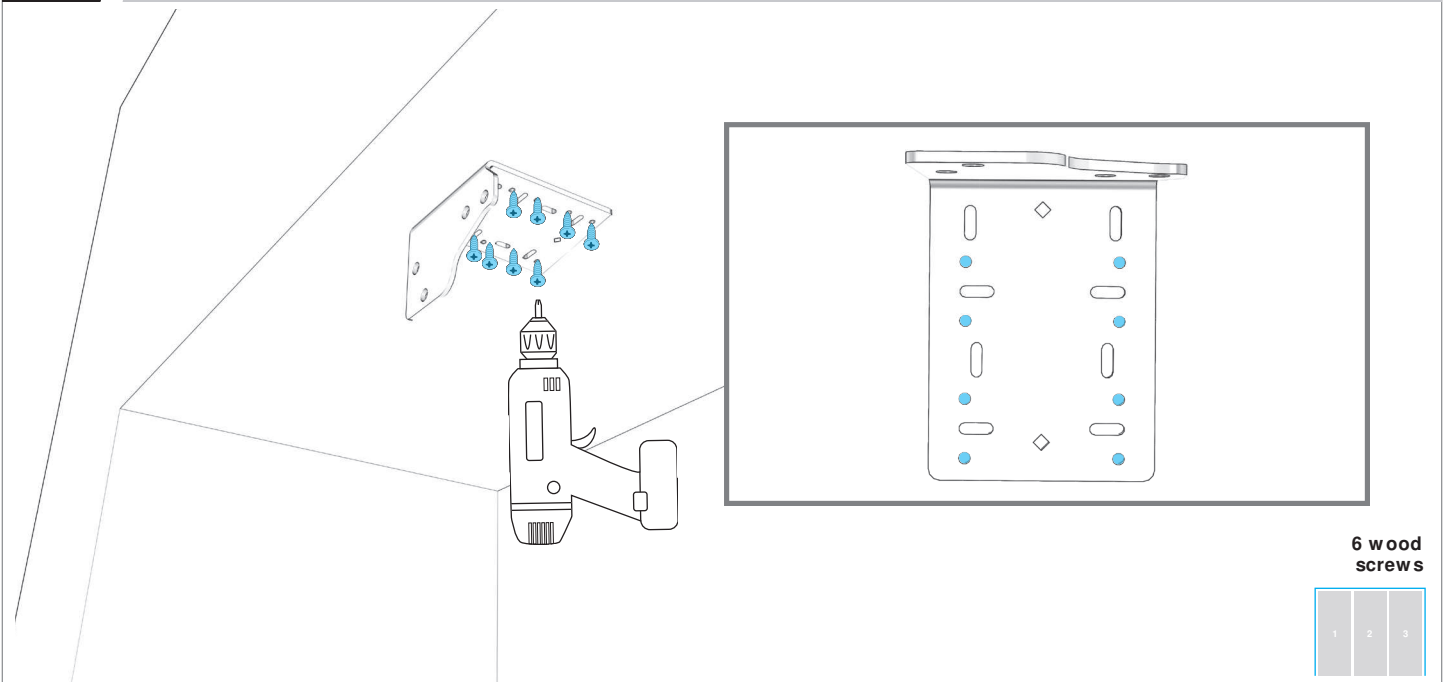

★ A MINIMUM OF SIX SCREWS MUST BE USED TO SECURE BRACKETS TO CABINET. FAILING TO PROPERLY SECURE BRACKETS CAN RESULT IN A TIP HAZARD.

4.12

IF INSTALLING ONLY TWO COLUMNS:
GO TO SECTION 5

4.13

IF INSTALLING THREE COLUMNS: ADD TOGETHER MODEL WIDTHS OF FIRST AND SECOND COLUMNS.

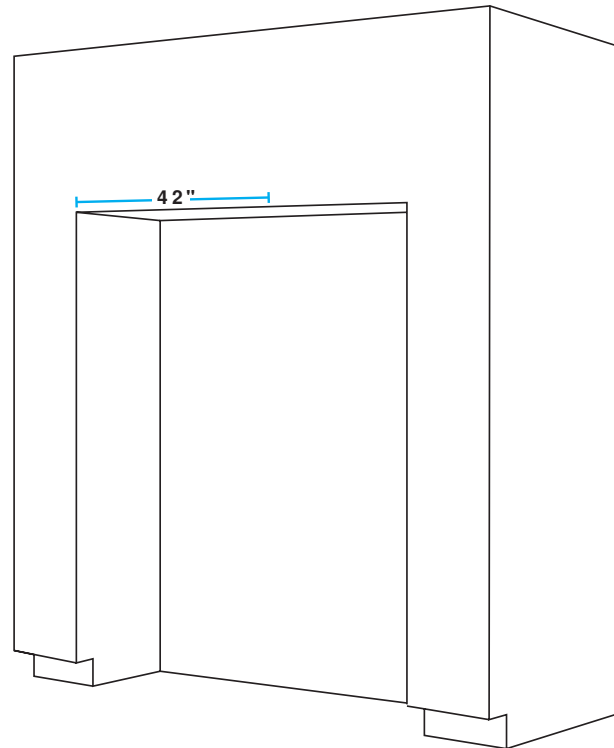
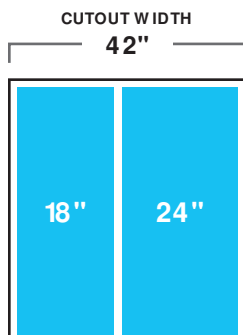

4.14

MARK LINE AT CALCULATED WIDTH.

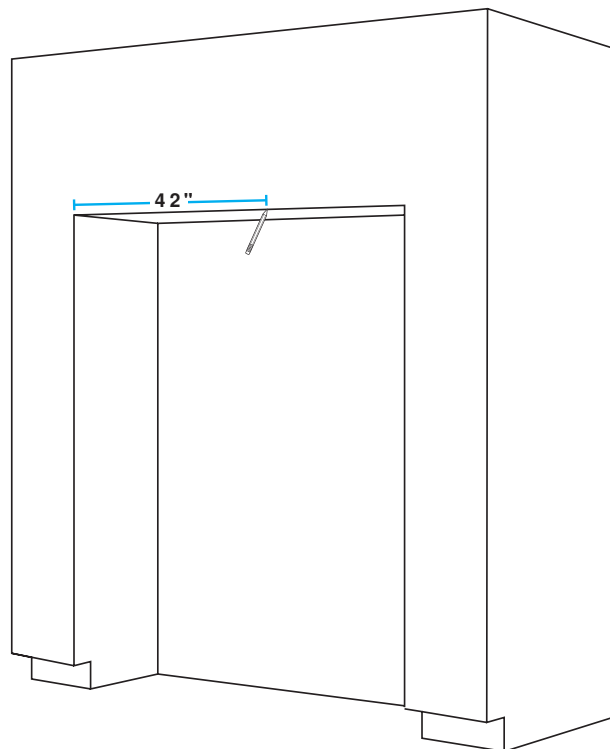

4

BADASS BRACKET INSTALLATION

4.15

COMPLETE 4.2 4.11.

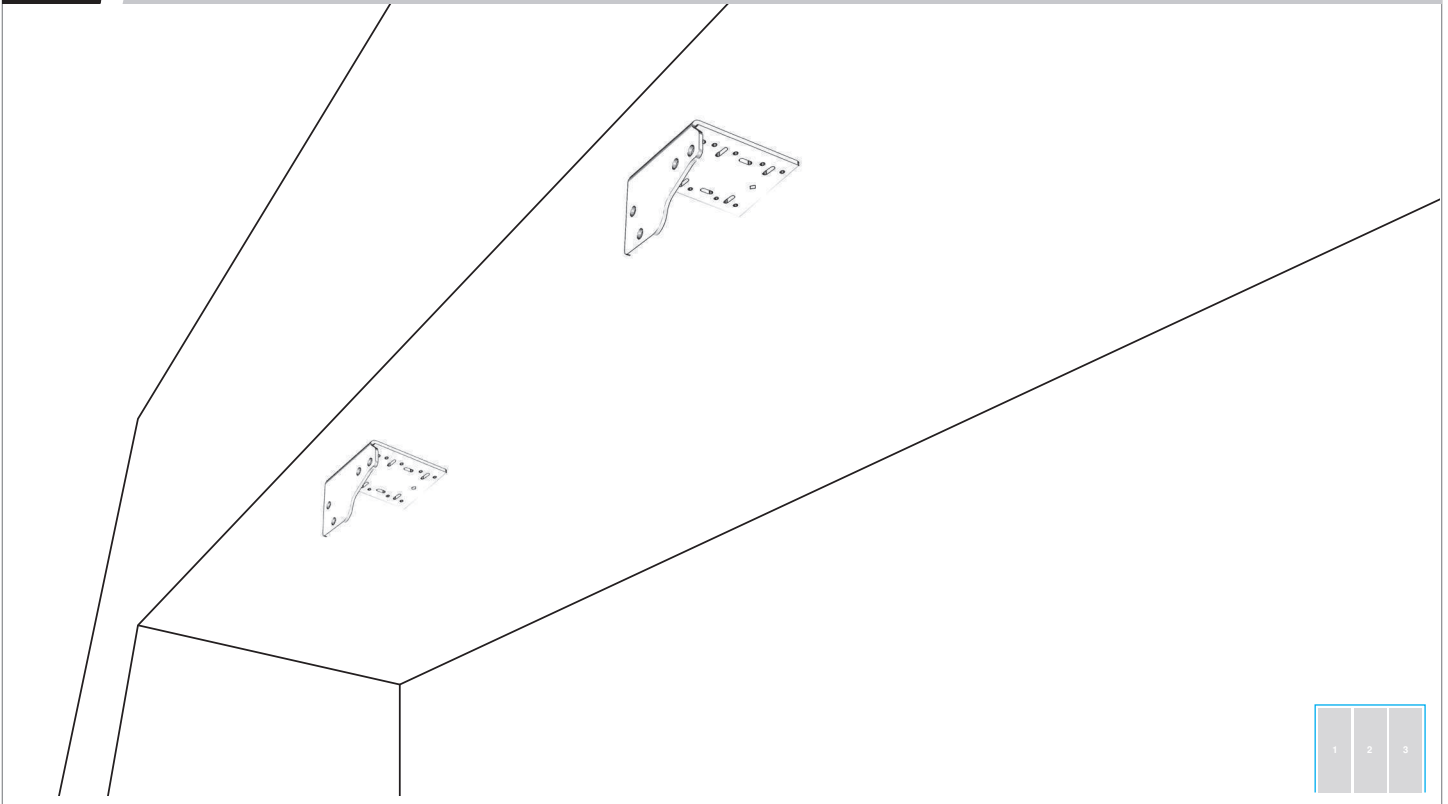

P R E P A R E
FURNITURE

5

PREPARE FURNITURE

5.1

MEASURE AND MARK LEFT PANEL LINE.

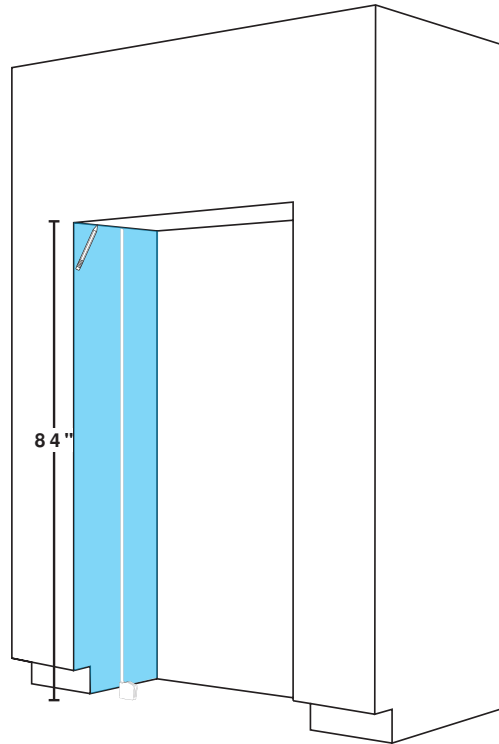

5.2

POSITION TEMPLATE ON LEFT PANEL.

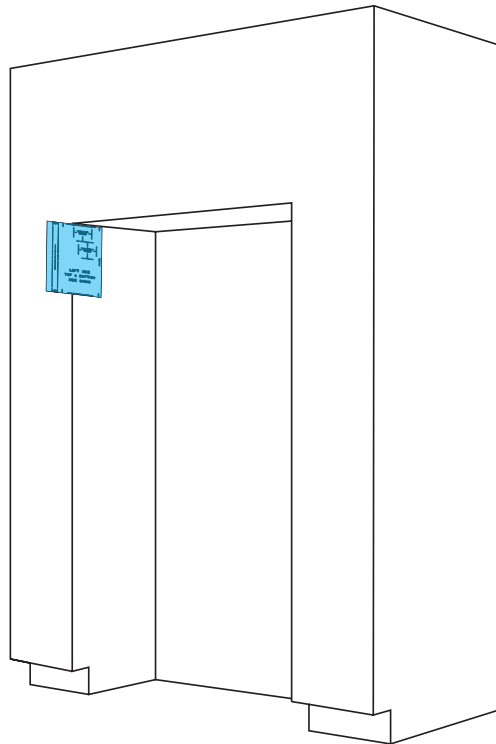

5.3

ALIGN DOOR STYLE LINE WITH CABINET FACE AND MARK ALIGNMENT LINES.

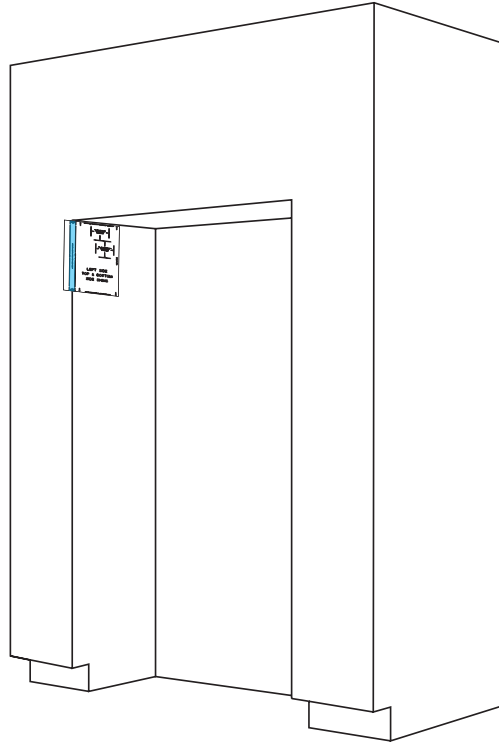

5.4

REPEAT 5.1 5.3 ON RIGHT PANEL.

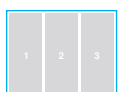
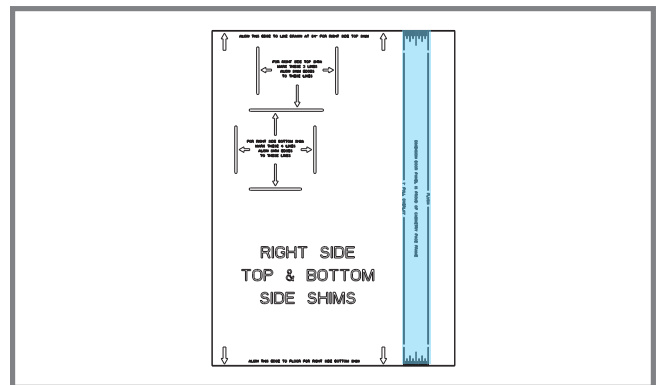
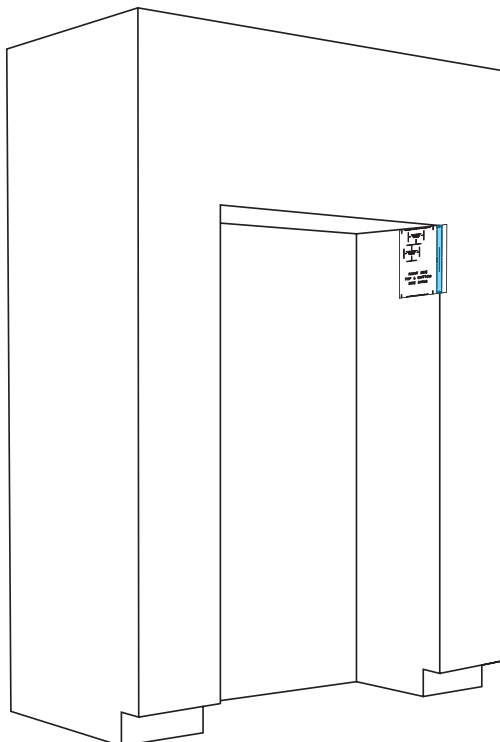

5

PREPARE FURNITURE

5.5

POSITION AND ALIGN TEMPLATE ON BOTTOM LEFT PANEL, MARKING SHIM ALIGNMENT LINES.

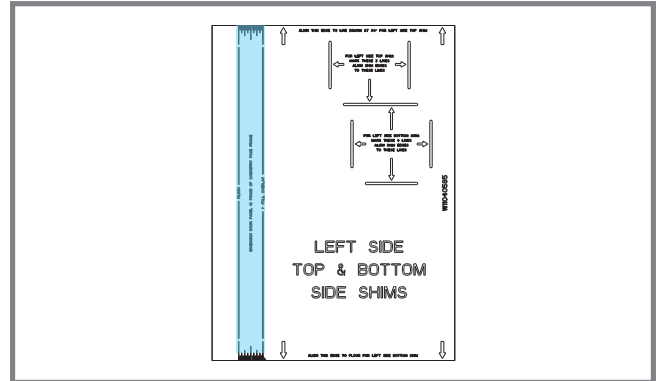
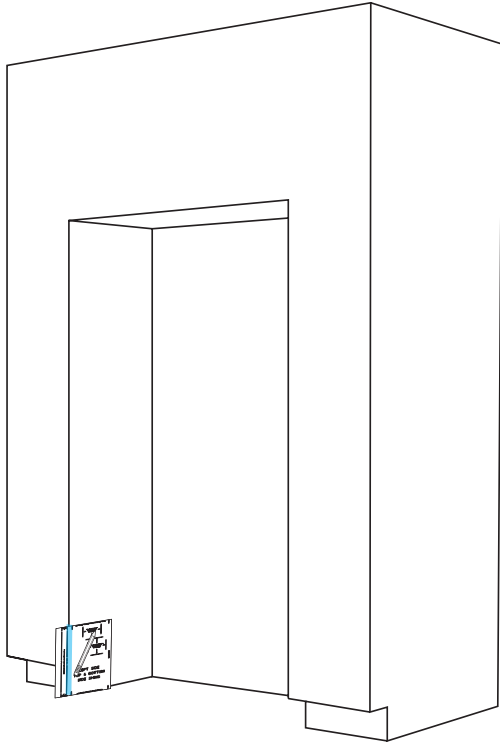

5.6

REPEAT STEP 5.5 ON RIGHT PANEL.

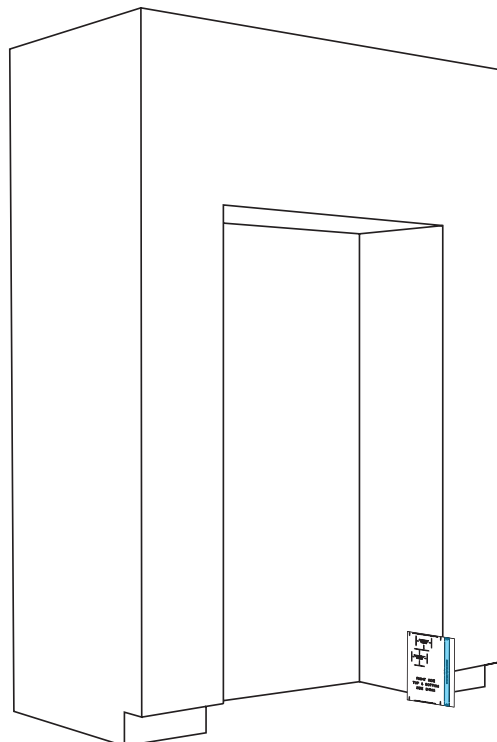

5.7

CRACK APART ROTTER SHIMS, ADHERE TO FOOTPRINTS.

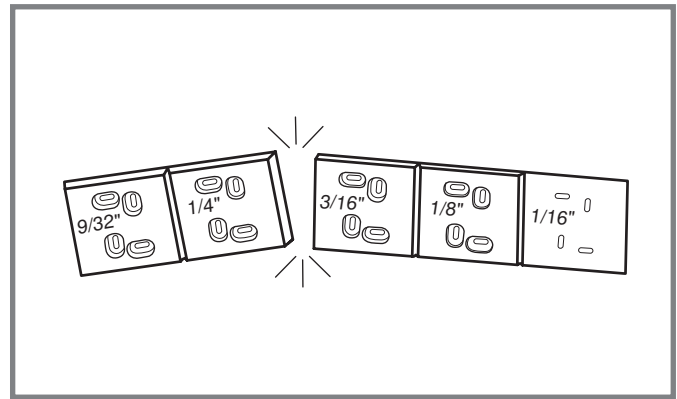
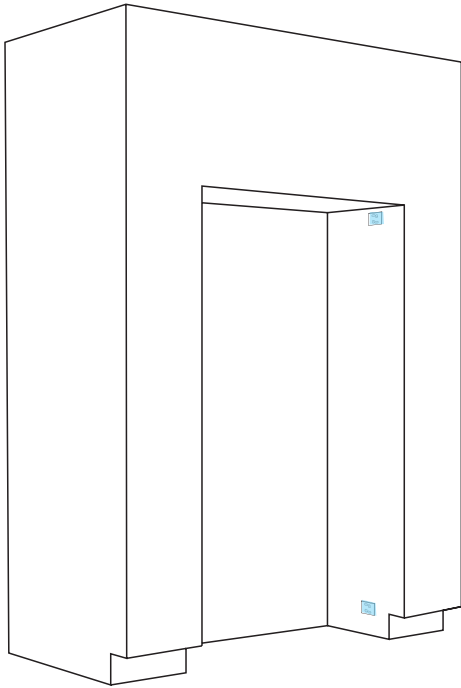

5.8

STACK ADDITIONAL SHIMS AS NEEDED.

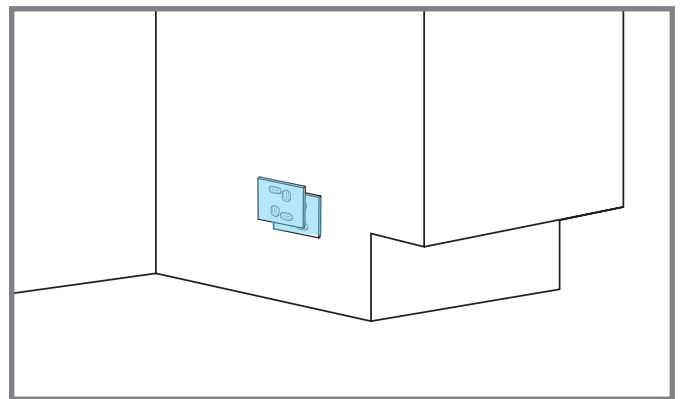
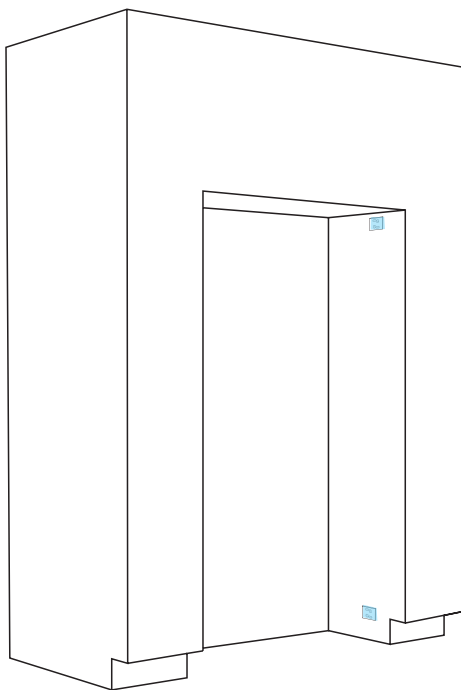

5

PREPARE FURNITURE

5.9

SECURE SHIMS TO SIDE PANELS TWO SCREWS REQUIRED .

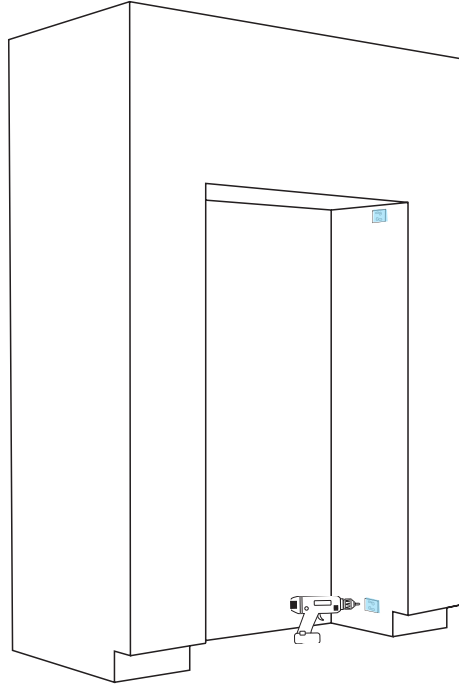

Wood screws



USE WOOD SCREWS OF AN APPROPRIATE LENGTH

5.10

TAPE WATER LINES TO FLOOR.

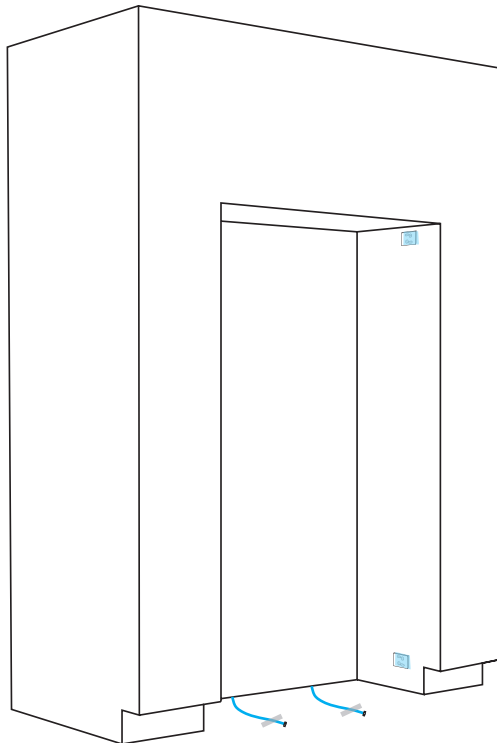



FIRST
COLUMN INSTALLATION

6

FIRST COLUMN INSTALLATION

6.1

SWITCH POWER OFF.

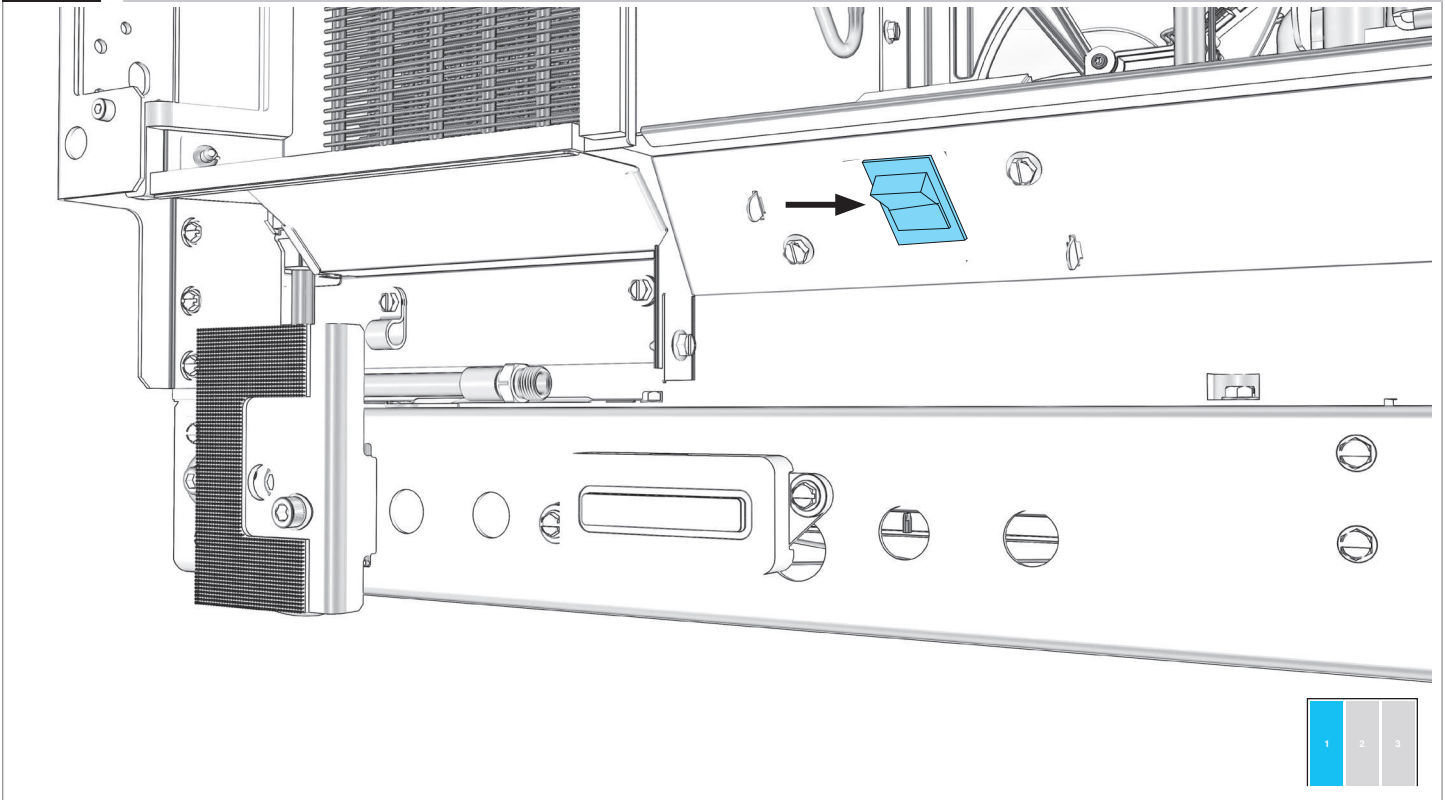

BEFORE PLUGGING IN COLUMN, READ WARNING.

⚠ WARNING



Electrical Shock Hazard

Plug into a grounded 3 prong outlet.

Do not remove ground prong.

Do not use an adapter.

Do not use an extension cord.

Failure to follow these instructions can result in death, fire, or electrical shock.

6.2

PLUG INTO GROUNDED 3 PRONG OUTLET.

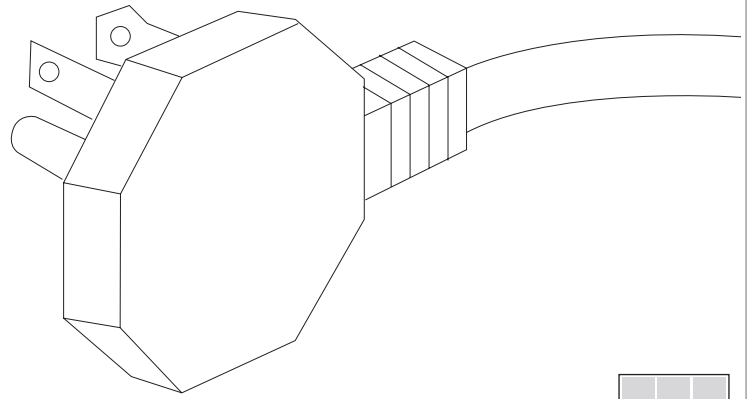
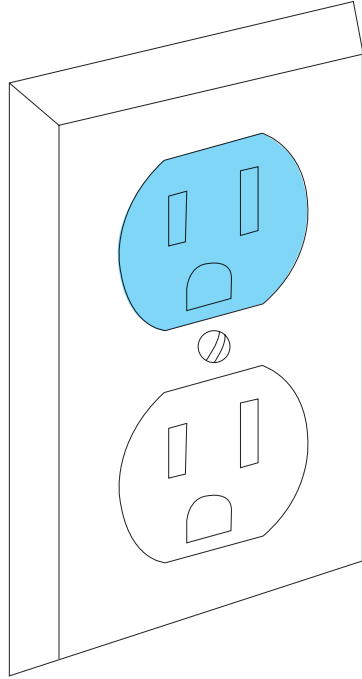

BEFORE MOVING COLUMN, READ WARNING.

⚠ WARNING



Tip Over Hazard

Refrigerator is top heavy and tips easily when not completely installed.

Keep doors taped closed until refrigerator is completely installed.

Use two or more people to move and install refrigerator.

Failure to do so can result in death or serious injury.

When Moving Your Refrigerator:

Your refrigerator is heavy. When moving the refrigerator for cleaning or service, be sure to cover the floor with cardboard or hardboard to avoid floor damage. Always pull the refrigerator straight out when moving it. Do not wiggle or “walk” the refrigerator when trying to move it, as floor damage could occur.

Important information to know about glass shelves and covers:

Do not clean glass shelves or covers with warm water when they are cold. Shelves and covers may break if exposed to sudden temperature changes or impact, such as bumping. Tempered glass is designed to shatter into many small, pebble-size pieces. This is normal. Glass shelves and covers are heavy. Use both hands when removing them to avoid dropping.

6

FIRST COLUMN INSTALLATION

6.3

MOVE COLUMN INTO THE CUTOUT.

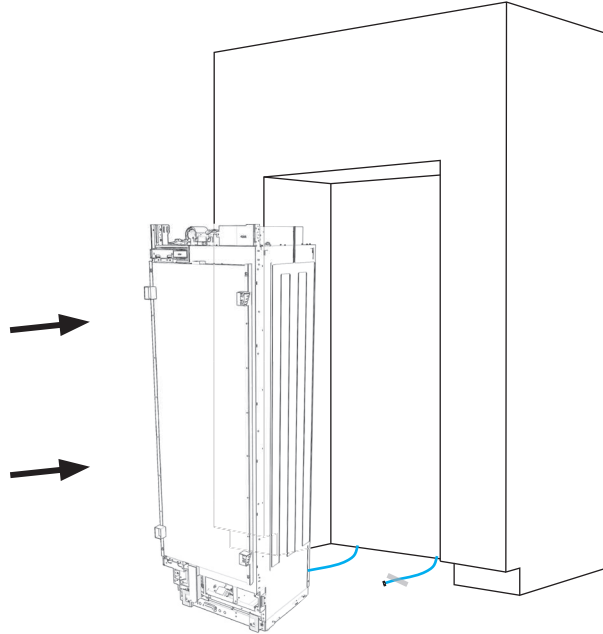

DO NOT DAMAGE THE WATER LINE.

6.4

USE DEPTH GAUGES TO ALIGN BASED ON DOOR STYLE .

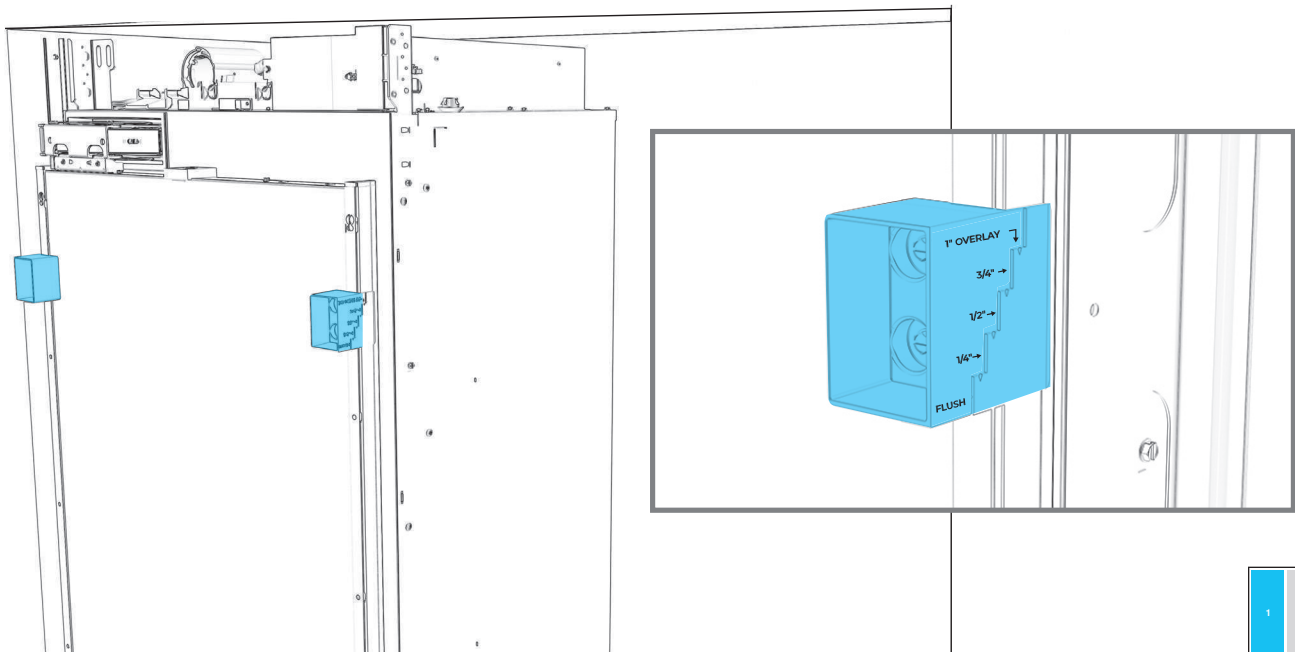

6.5

EXTEND ROLLERS INDIVIDUALLY.

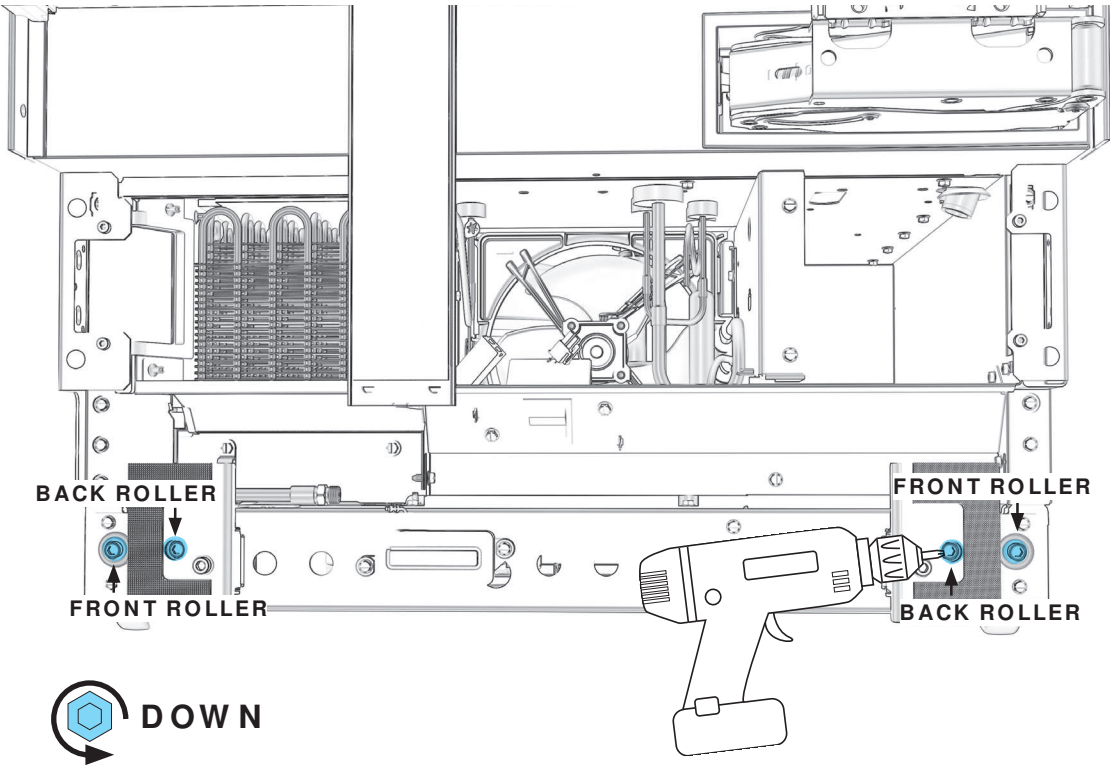

6.6

MAKE SURE INSTALLATION BRACKET ALIGNS WITH 84" LINE.

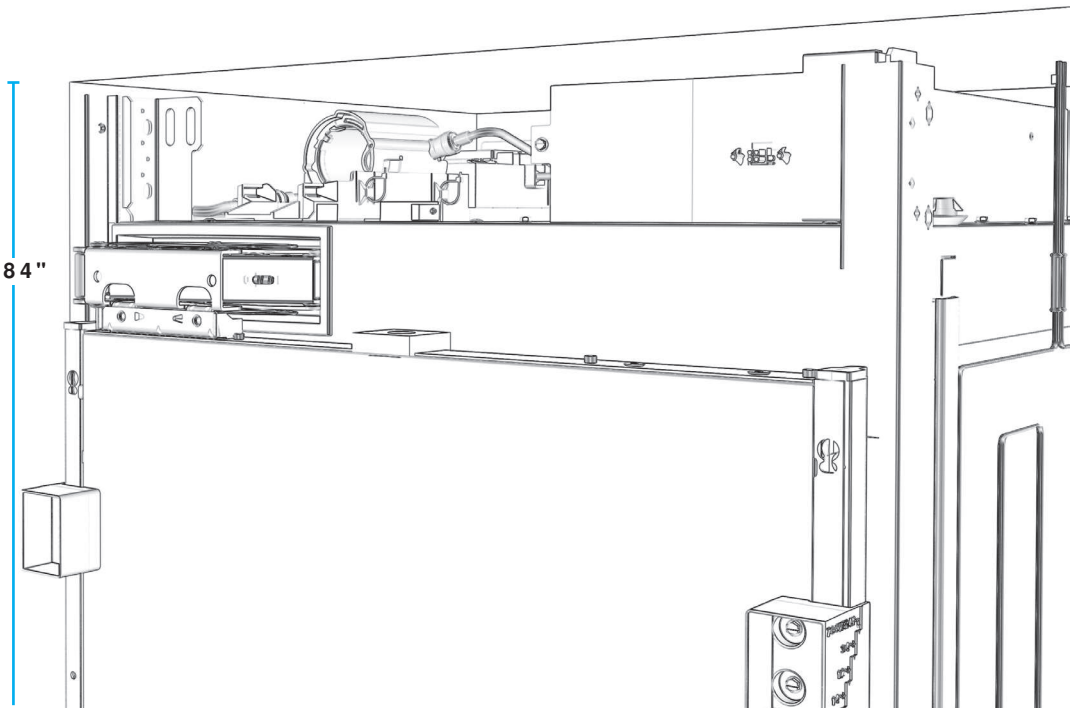

6

FIRST COLUMN INSTALLATION

6.7

CHECK THAT DEPTH GAUGES INDICATE SAME DEPTH.

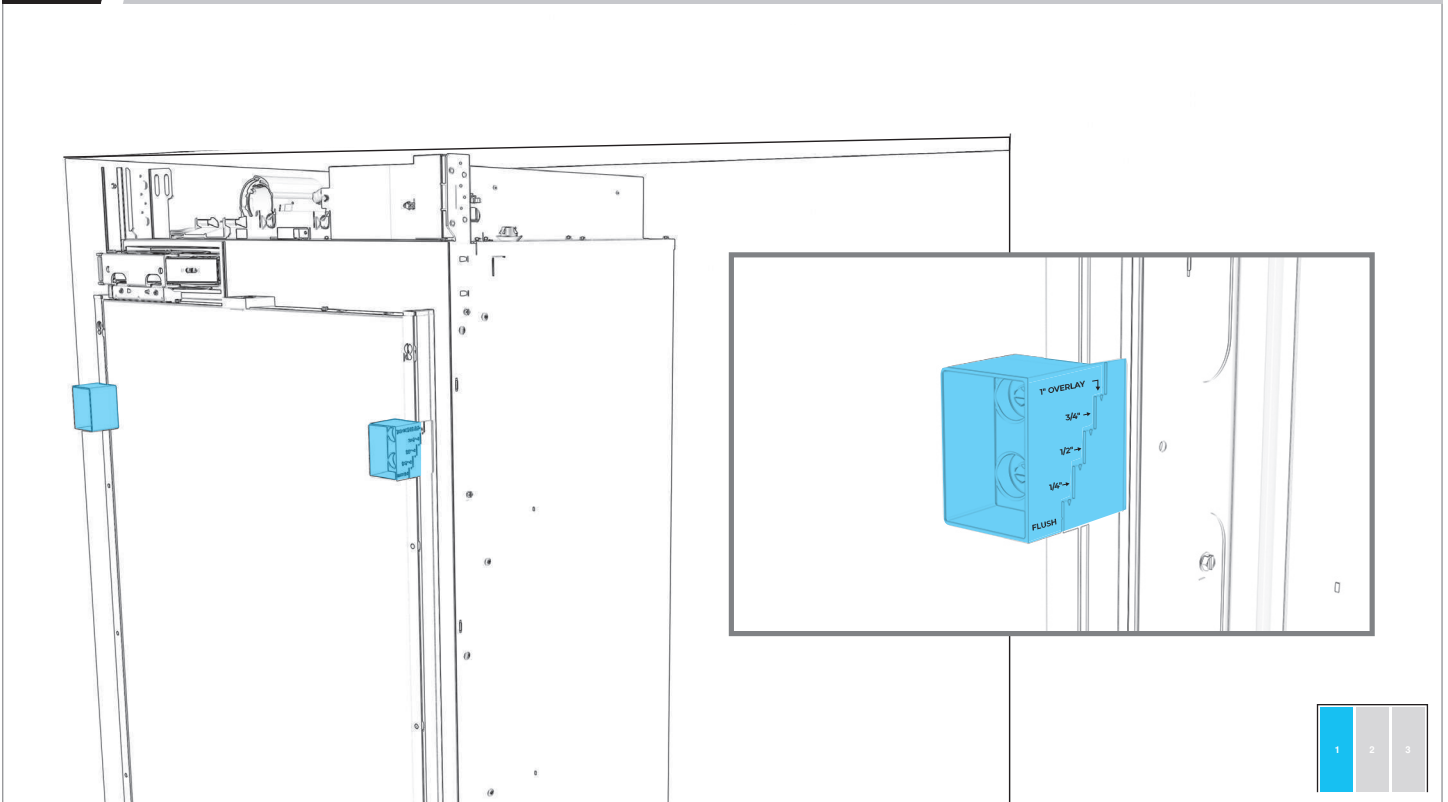

6.8

ADJUST ROLLERS UNTIL DEPTH GAUGES MATCH.

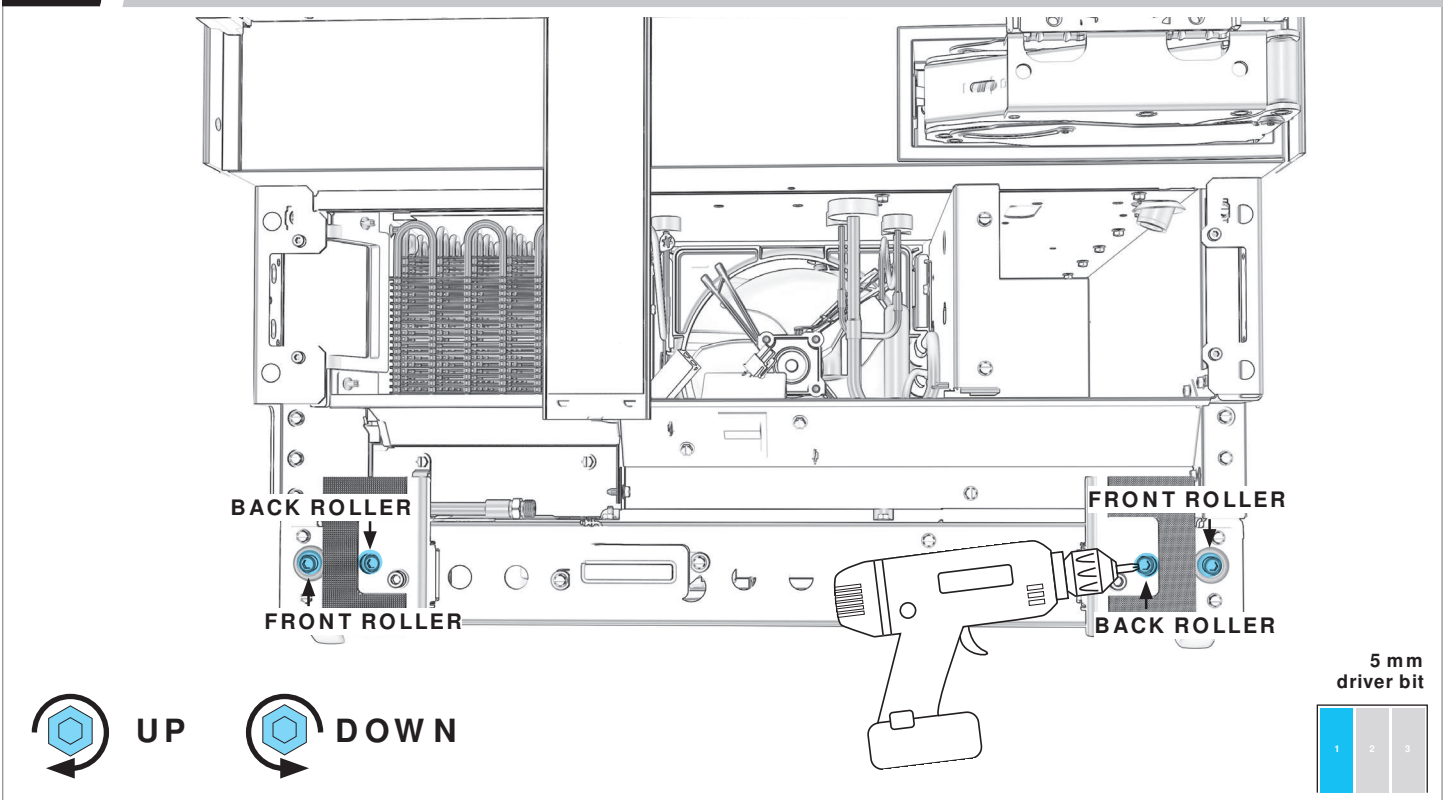

6.9

LOOSELY DRIVE SCREWS THROUGH INSTALLATION BRACKET AND BADASS SOFFIT BRACKET.

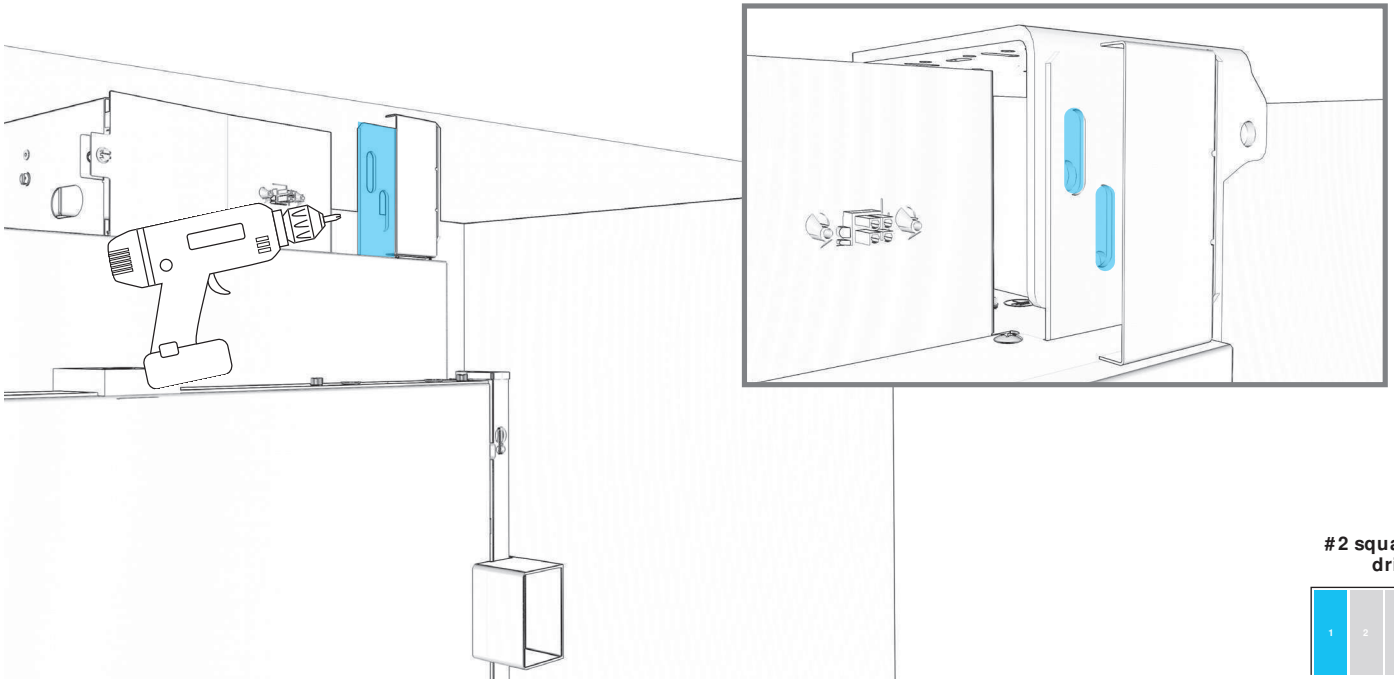

6.10

SECURE TOP INSTALLATION BRACKET TO FURNITURE.

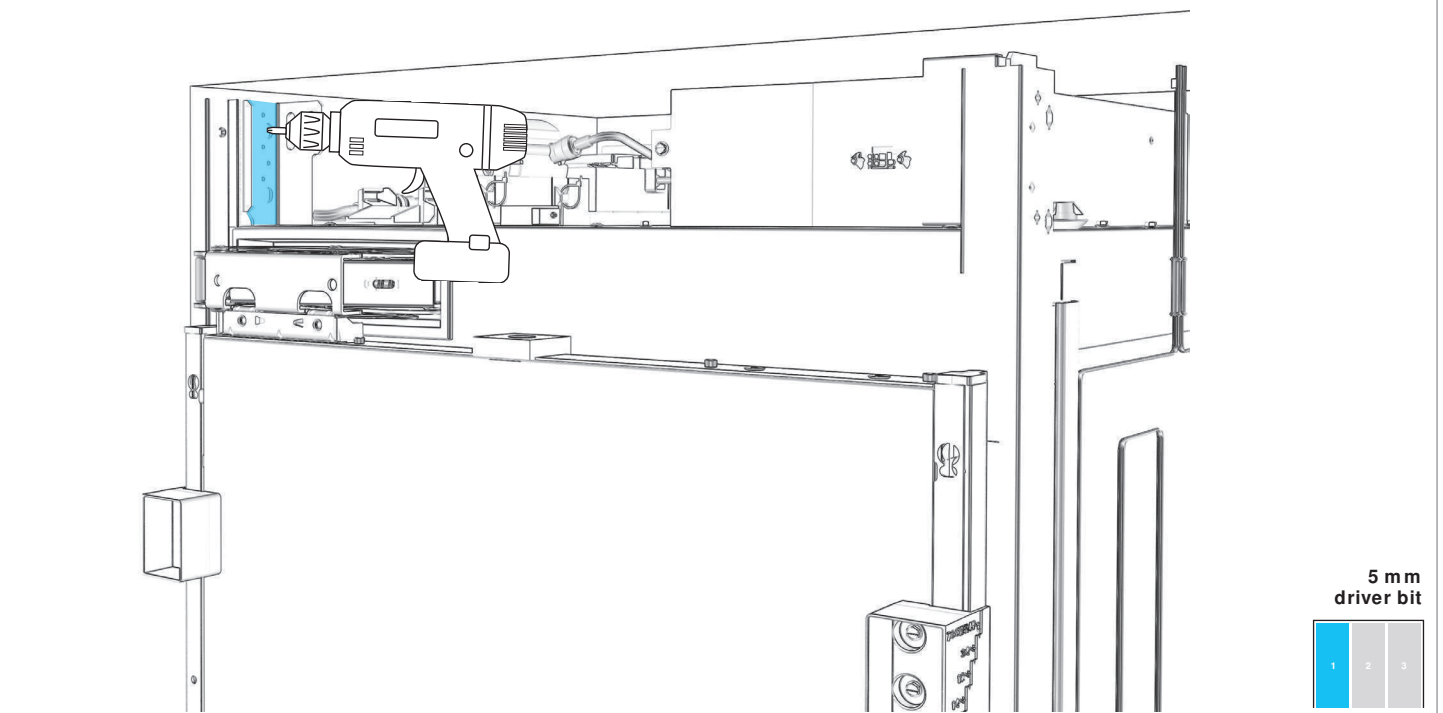

6

FIRST COLUMN INSTALLATION

6.11

SECURE BOTTOM INSTALLATION BRACKET TO FURNITURE.

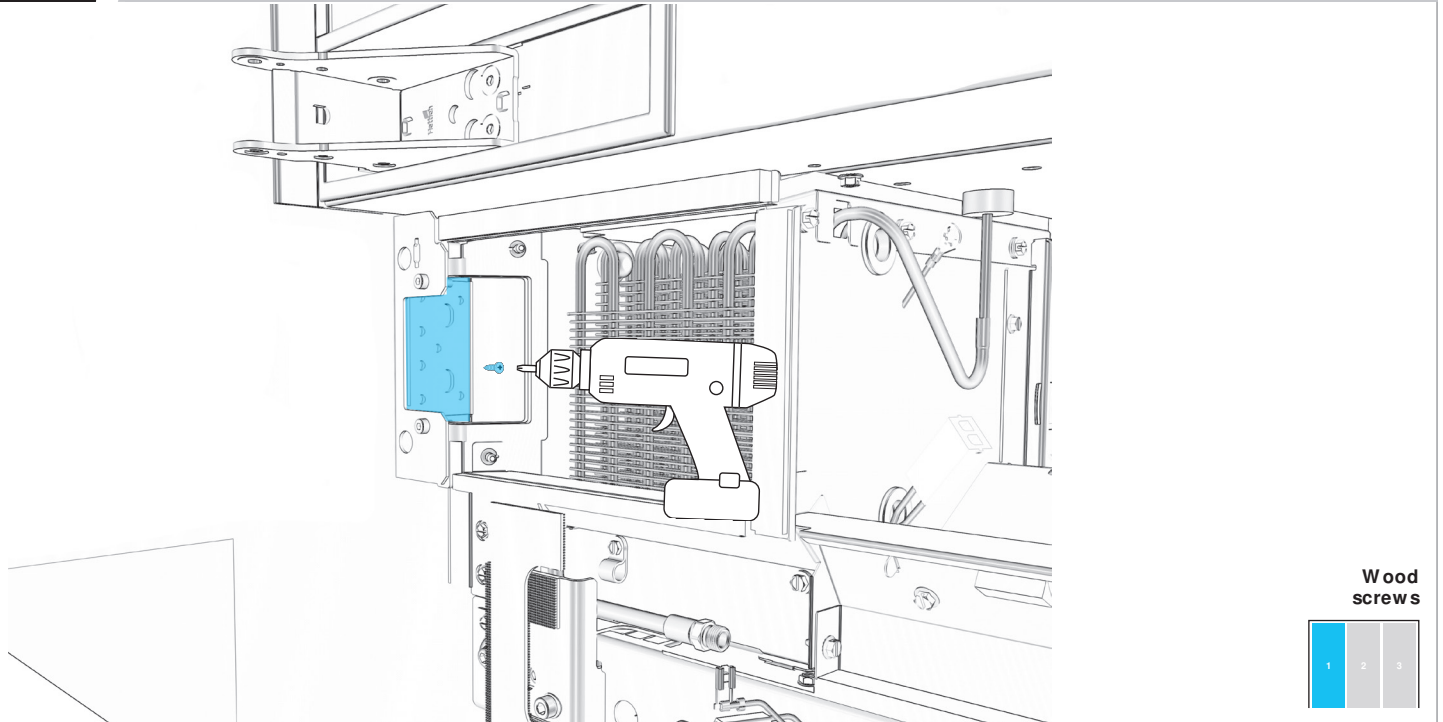

Wood
screws



USE WOOD SCREWS OF AN APPROPRIATE LENGTH.

6.12

POSITION BRACKET TO FLOOR AND WALL.

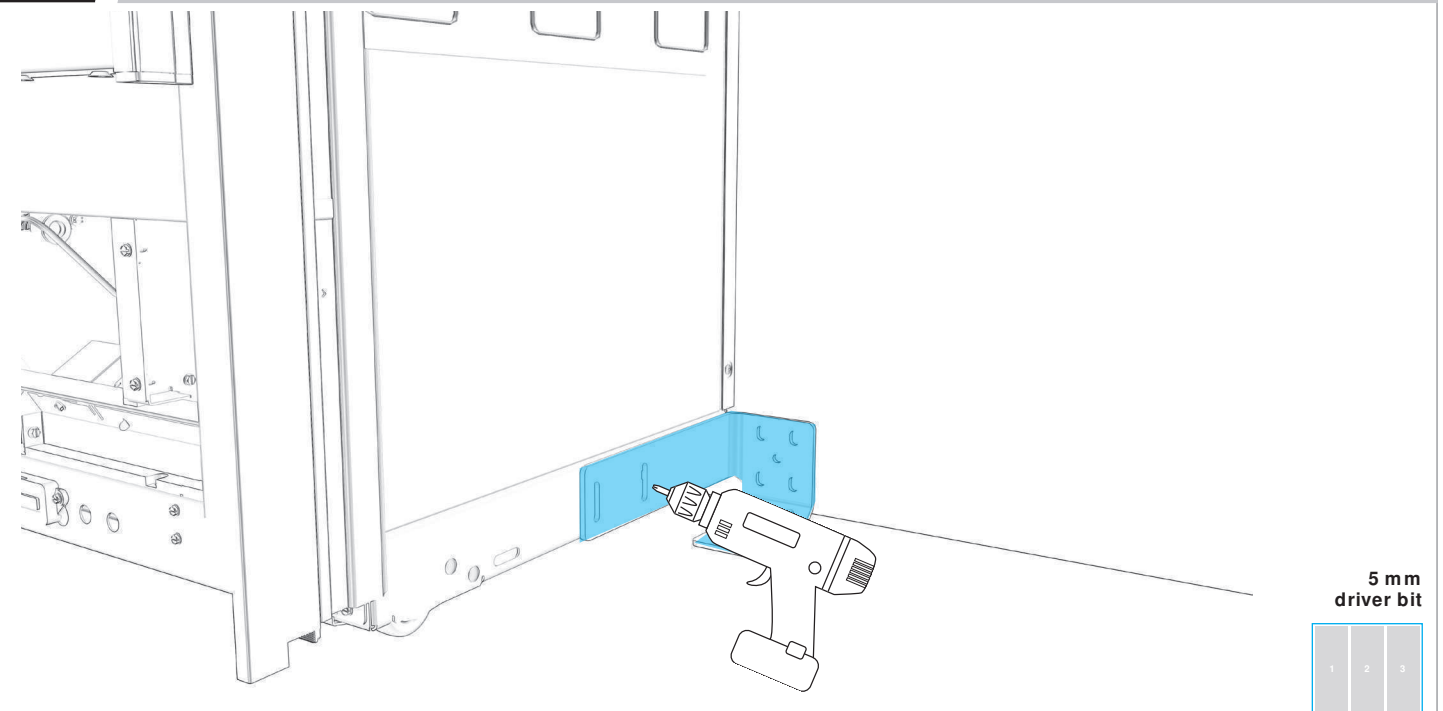

5 mm
driver bit



CONSIDER WALL AND FLOOR CONSTRUCTION AND MATERIALS.

6.13

SECURE POSITIONING BRACKET, USING AS MANY SLOTS AS POSSIBLE.

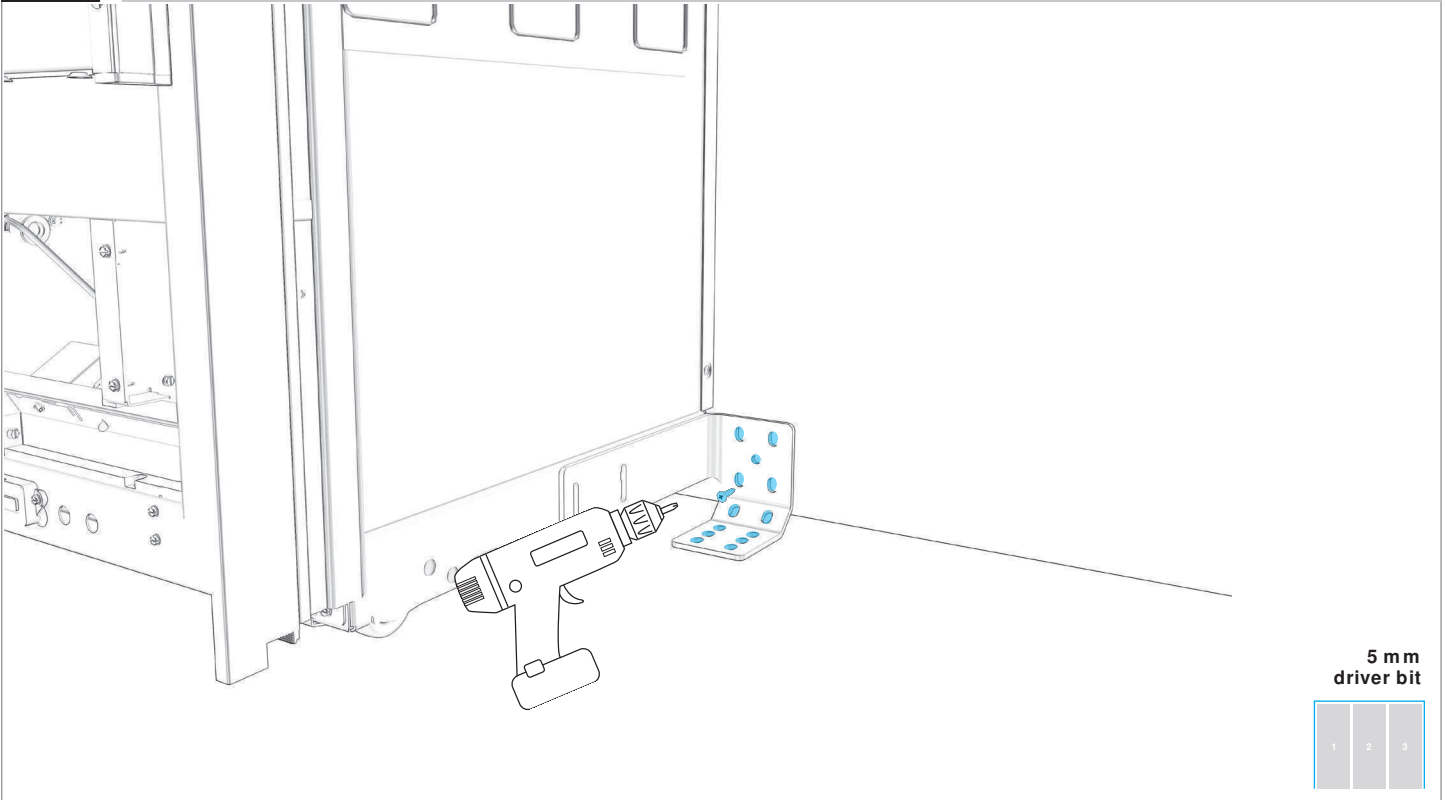

6.14

USE LEVEL TO CHECK DEPTH FROM FACE FRAME AT MULTIPLE POINTS.

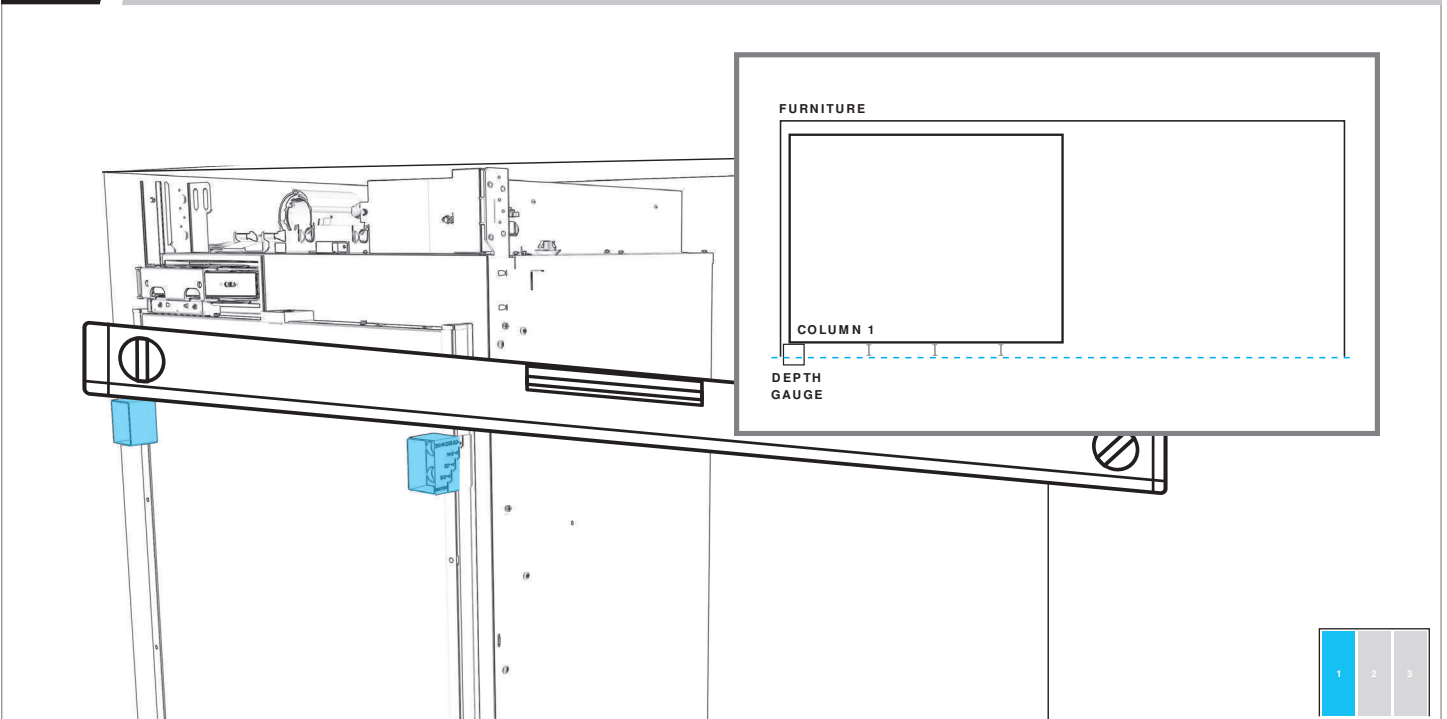

MAY SUBSTITUTE TRIM PIECE FOR LEVEL.

6

FIRST COLUMN INSTALLATION

6.15

READJUST COLUMN SO THAT ALL DEPTHS MATCH.

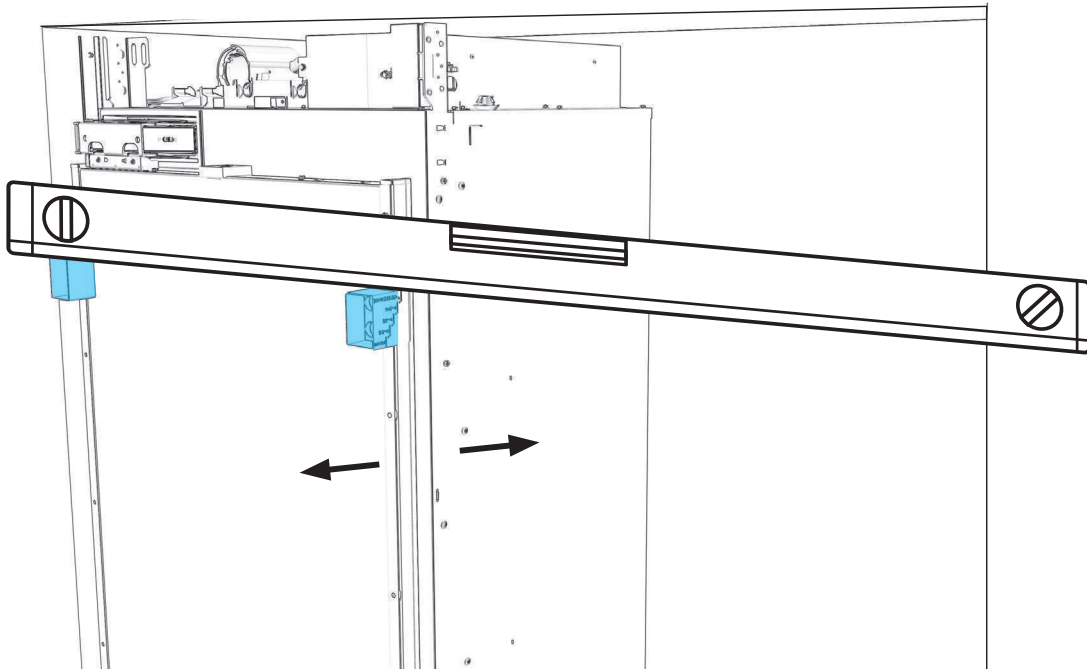

SECOND

COLUMN INSTALLATION

7

SECOND COLUMN INSTALLATION

7.1

SWITCH POWER OFF.

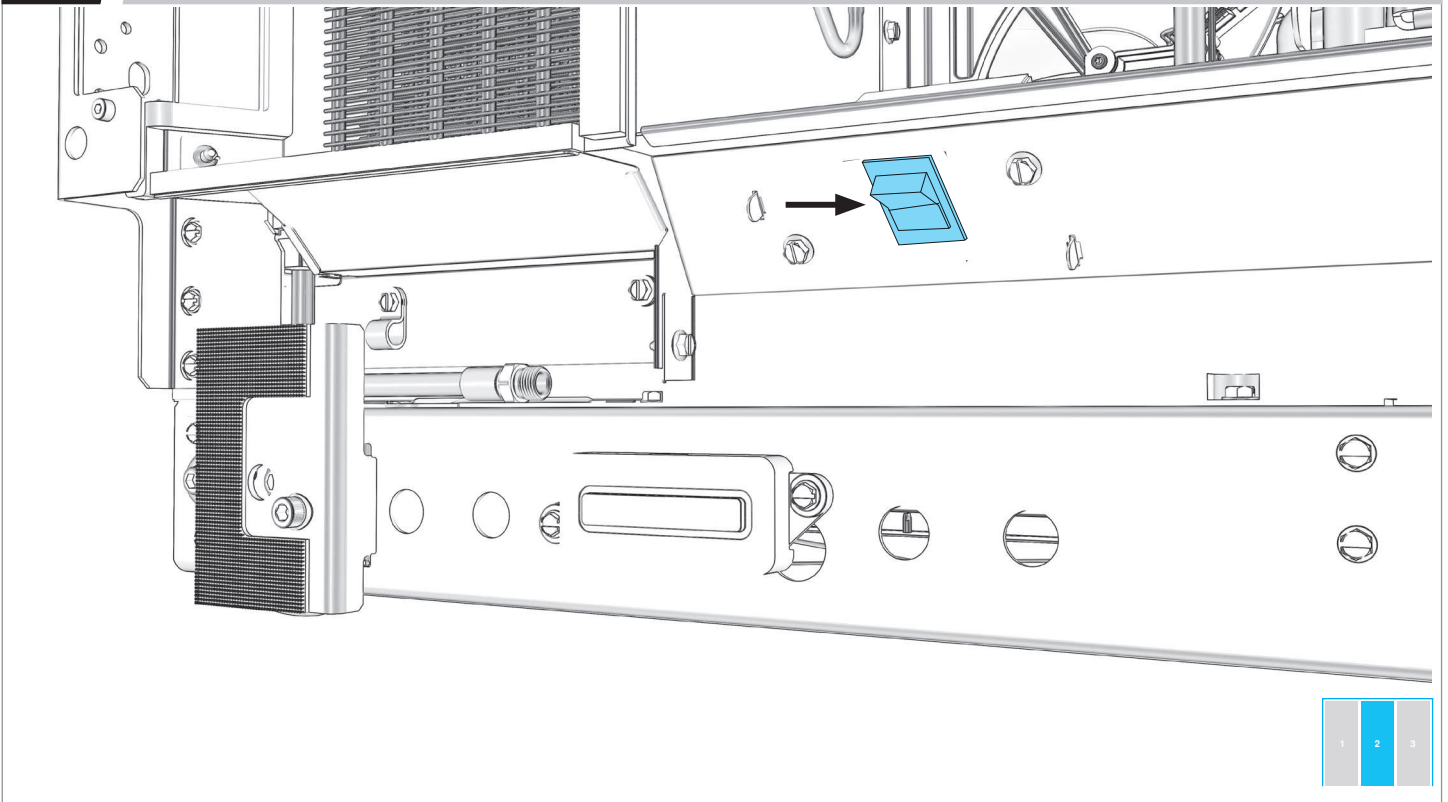

BEFORE PLUGGING IN COLUMN, READ WARNING.

⚠ WARNING



Electrical Shock Hazard

Plug into a grounded 3 prong outlet.

Do not remove ground prong.

Do not use an adapter.

Do not use an extension cord.

Failure to follow these instructions can result in death, fire, or electrical shock.

7.2

PLUG INTO GROUNDED 3 PRONG OUTLET.

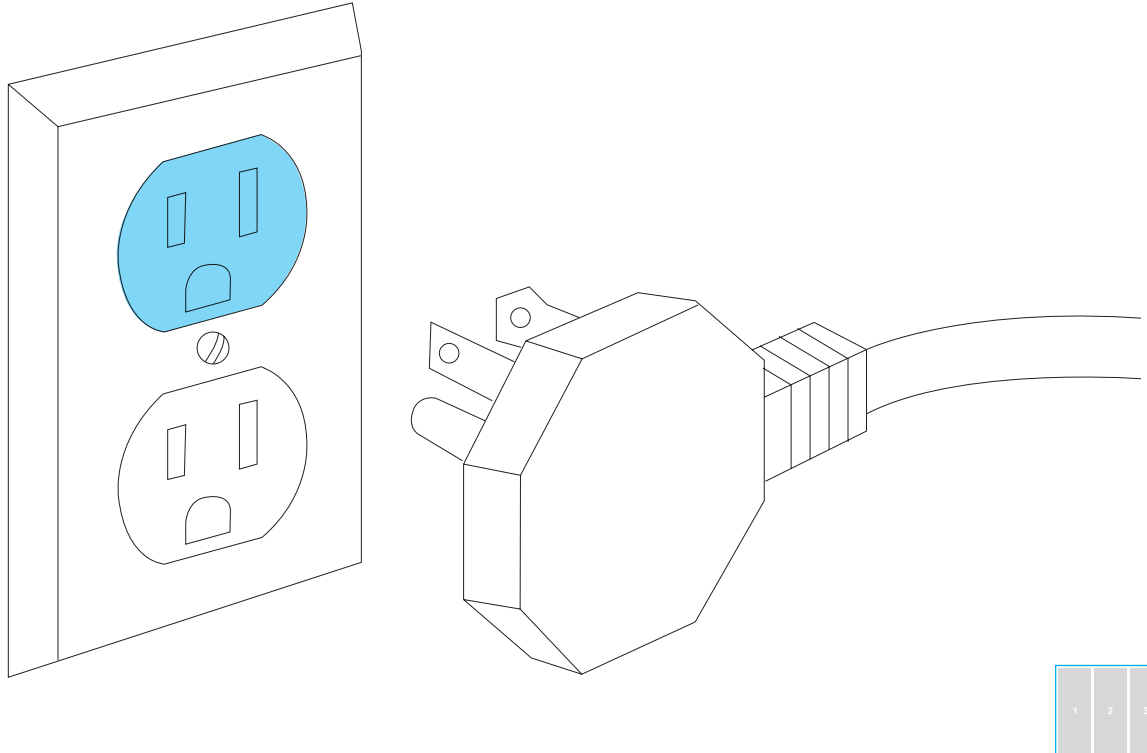

BEFORE MOVING COLUMNS, REVIEW ALL WARNINGS.

⚠️ WARNING



Tip Over Hazard

Refrigerator is top heavy and tips easily when not completely installed.

Keep doors taped closed until refrigerator is completely installed.

Use two or more people to move and install refrigerator.

Failure to do so can result in death or serious injury.

When Moving Your Refrigerator:

Your refrigerator is heavy. When moving the refrigerator for cleaning or service, be sure to cover the floor with cardboard or hardboard to avoid floor damage. Always pull the refrigerator straight out when moving it. Do not wiggle or “walk” the refrigerator when trying to move it, as floor damage could occur.

Important information to know about glass shelves and covers:

Do not clean glass shelves or covers with warm water when they are cold. Shelves and covers may break if exposed to sudden temperature changes or impact, such as bumping. Tempered glass is designed to shatter into many small, pebble-size pieces. This is normal. Glass shelves and covers are heavy. Use both hands when removing them to avoid dropping.

7

SECOND COLUMN INSTALLATION

7.3

SECOND COLUMN: MOVE INTO THE CUTOUT.

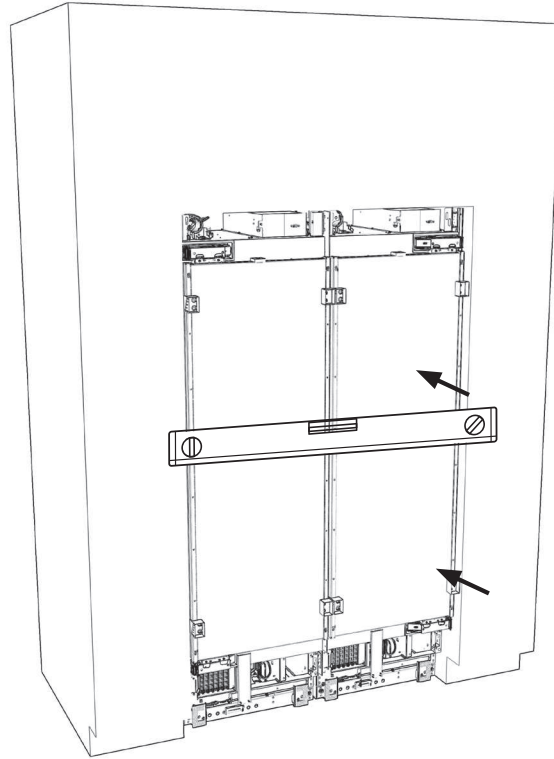

7.4

IF INSTALLING THREE COLUMNS:
GO TO SECTION 8

7.5 SECOND COLUMN: RAISE TO 84" LINE.

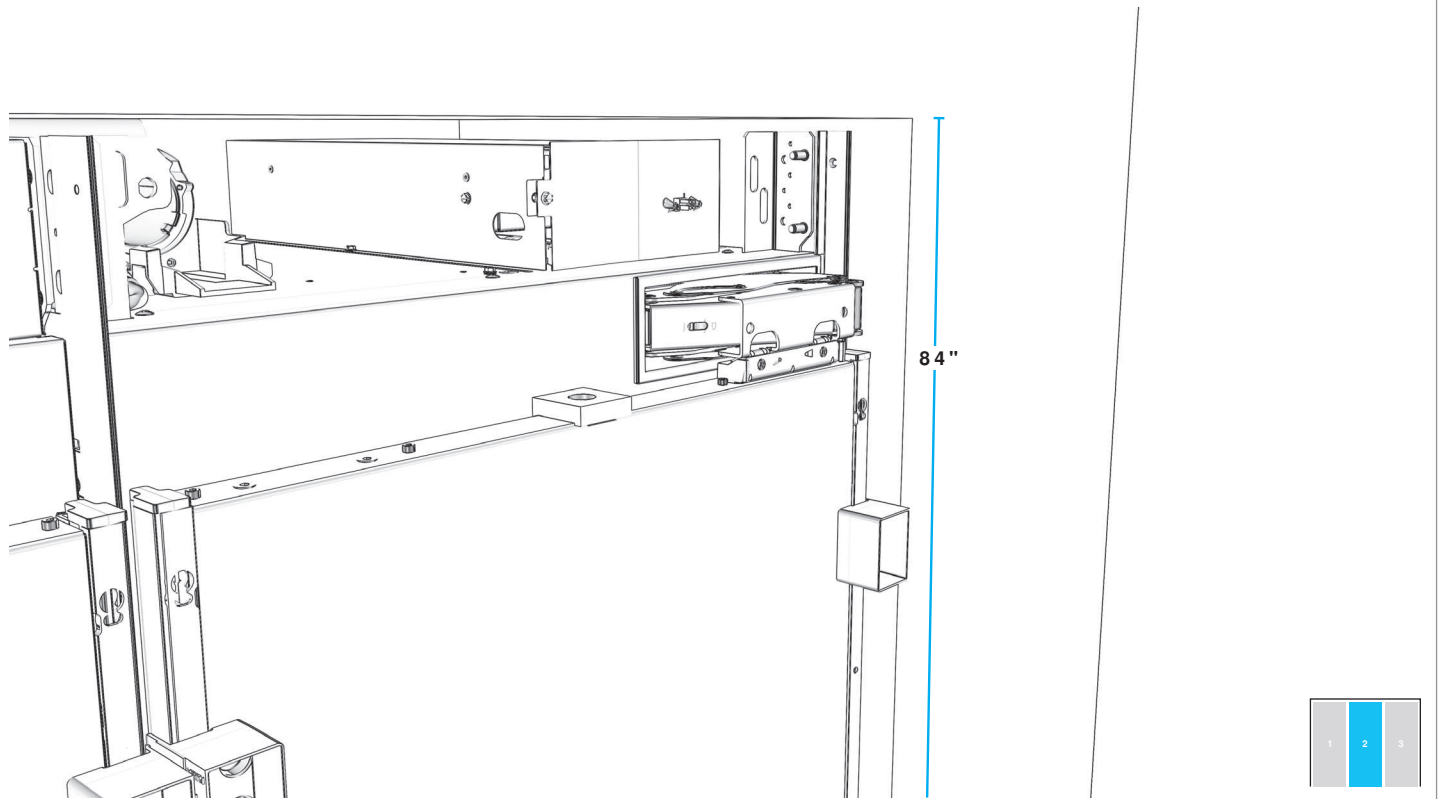

7.6 SECURE FIRST UNIT TO SECOND UNIT AT TOP.

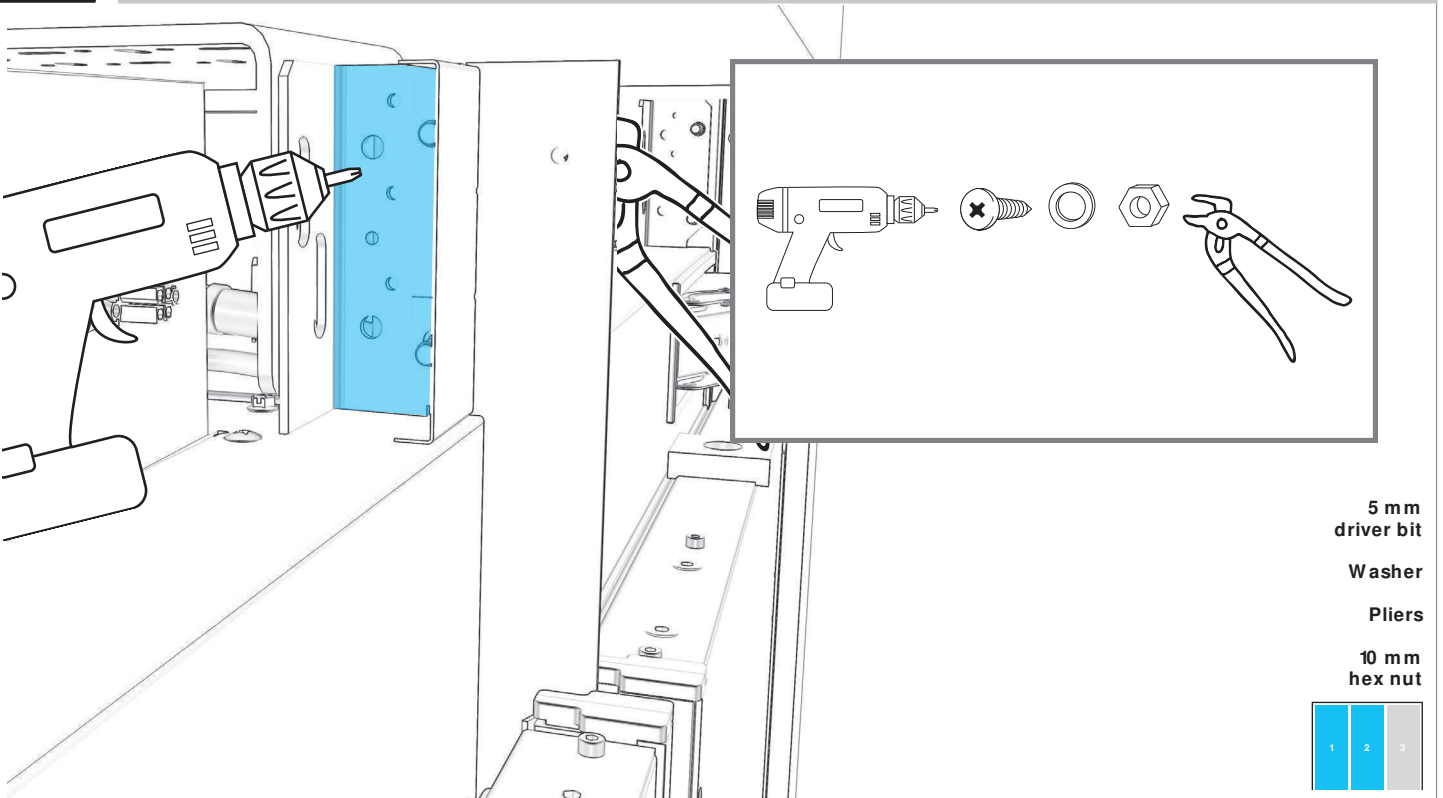

- 5 mm driver bit
- Washer
- Pliers
- 10 mm hex nut

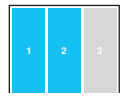

7.7

REPEAT ON BOTTOM BRACKET.

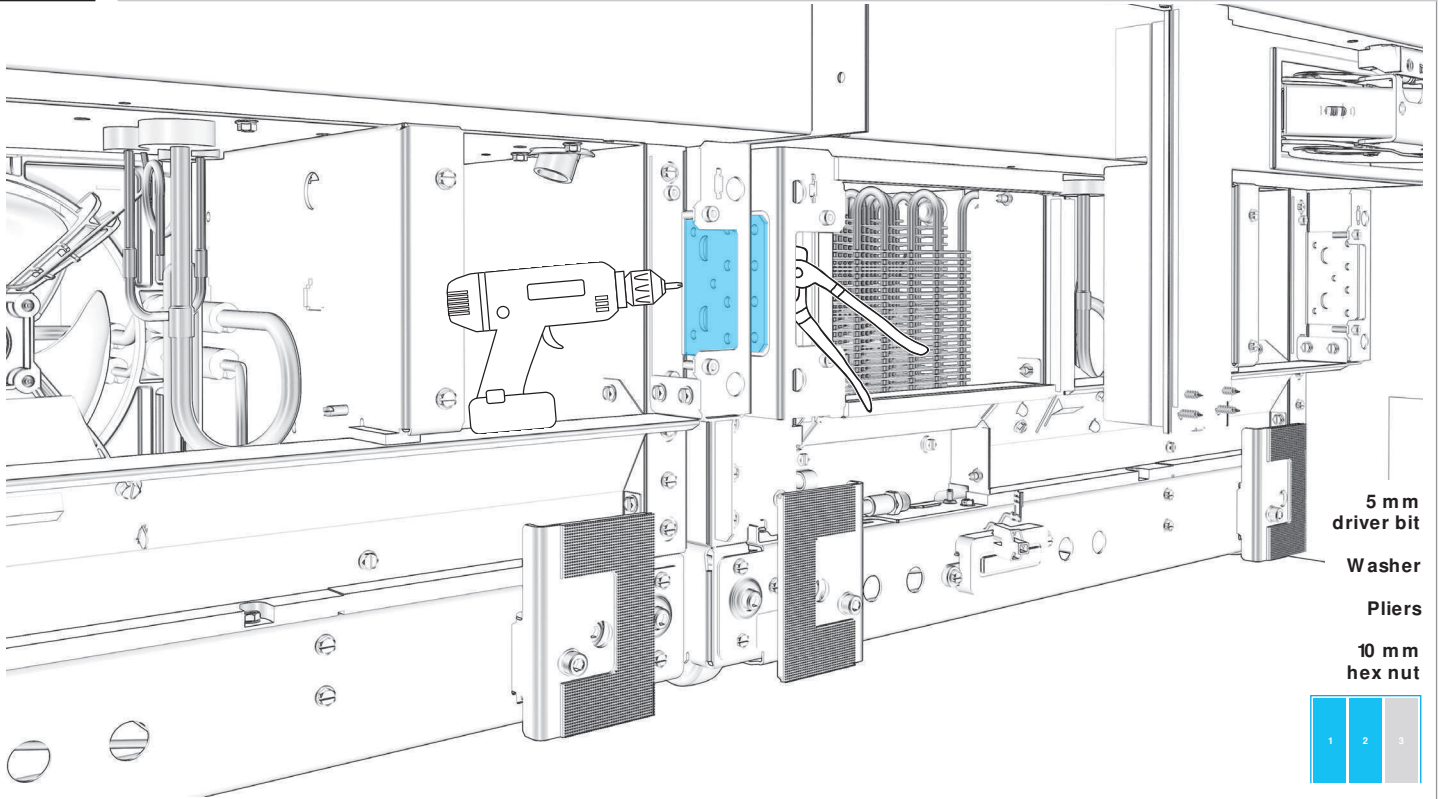

7.8

SECURE TOP INSTALLATION BRACKET TO FURNITURE.

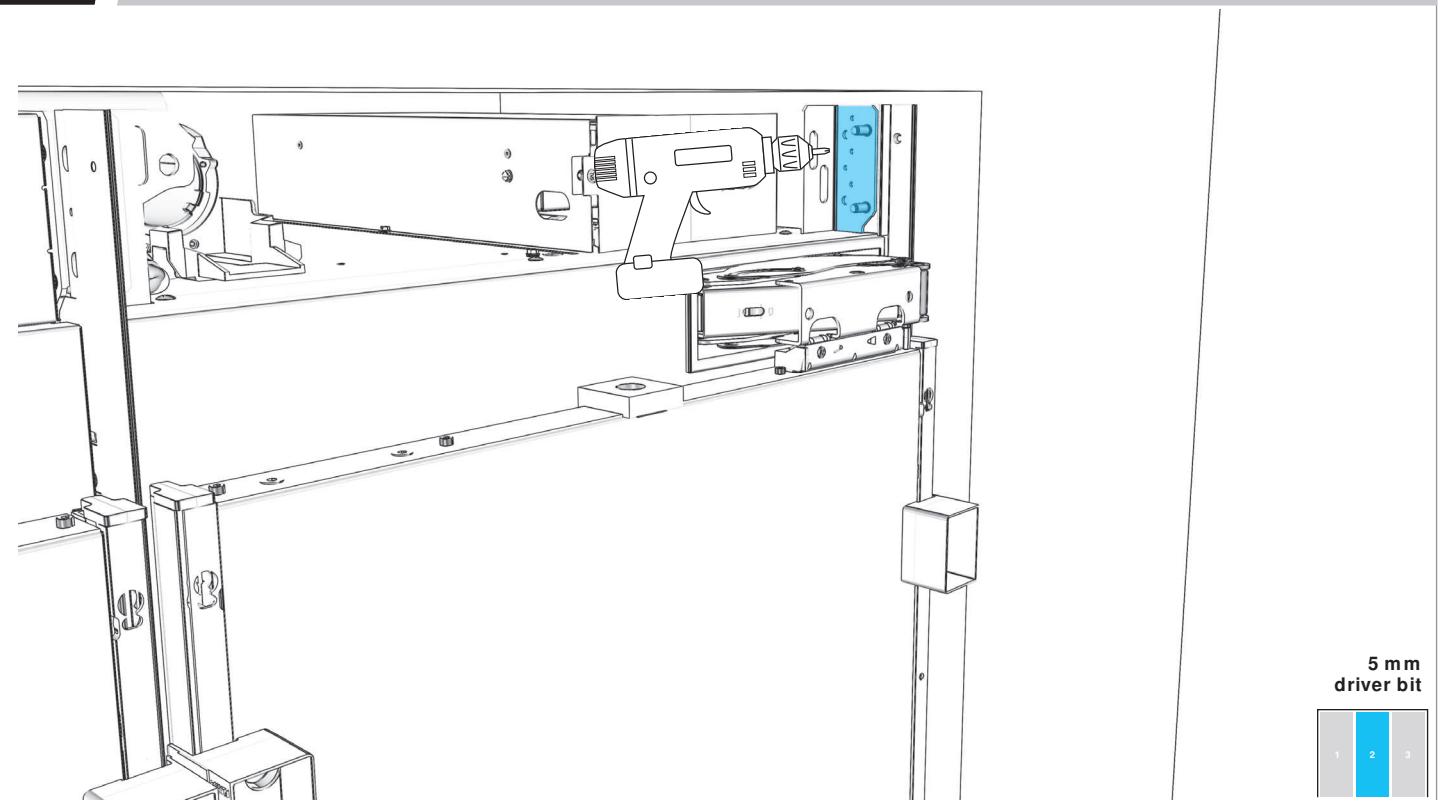

7.9 SECURE BOTTOM INSTALLATION BRACKET TO FURNITURE.

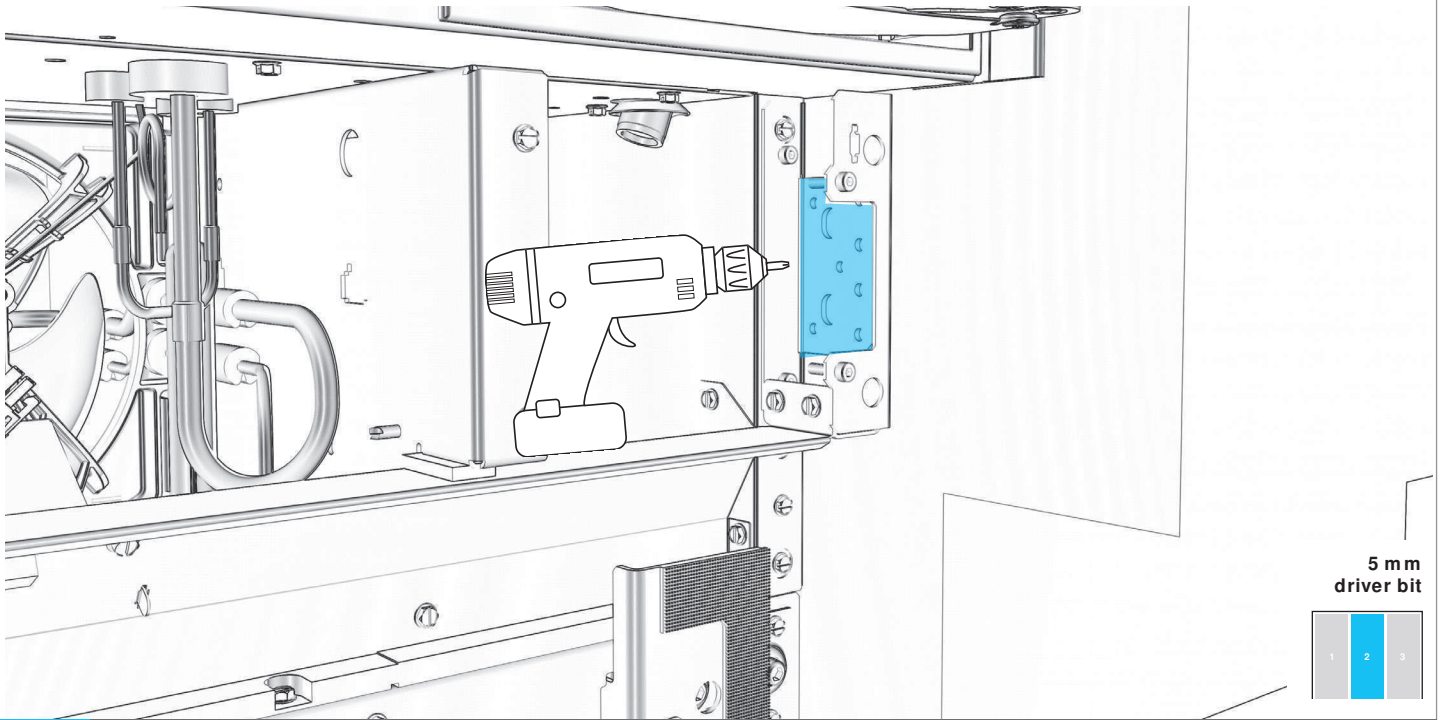

5 mm
driver bit

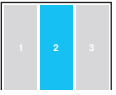

USE WOOD SCREWS OF AN APPROPRIATE LENGTH

7.10 CONNECT THE WATER SUPPLY LINES.

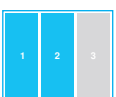
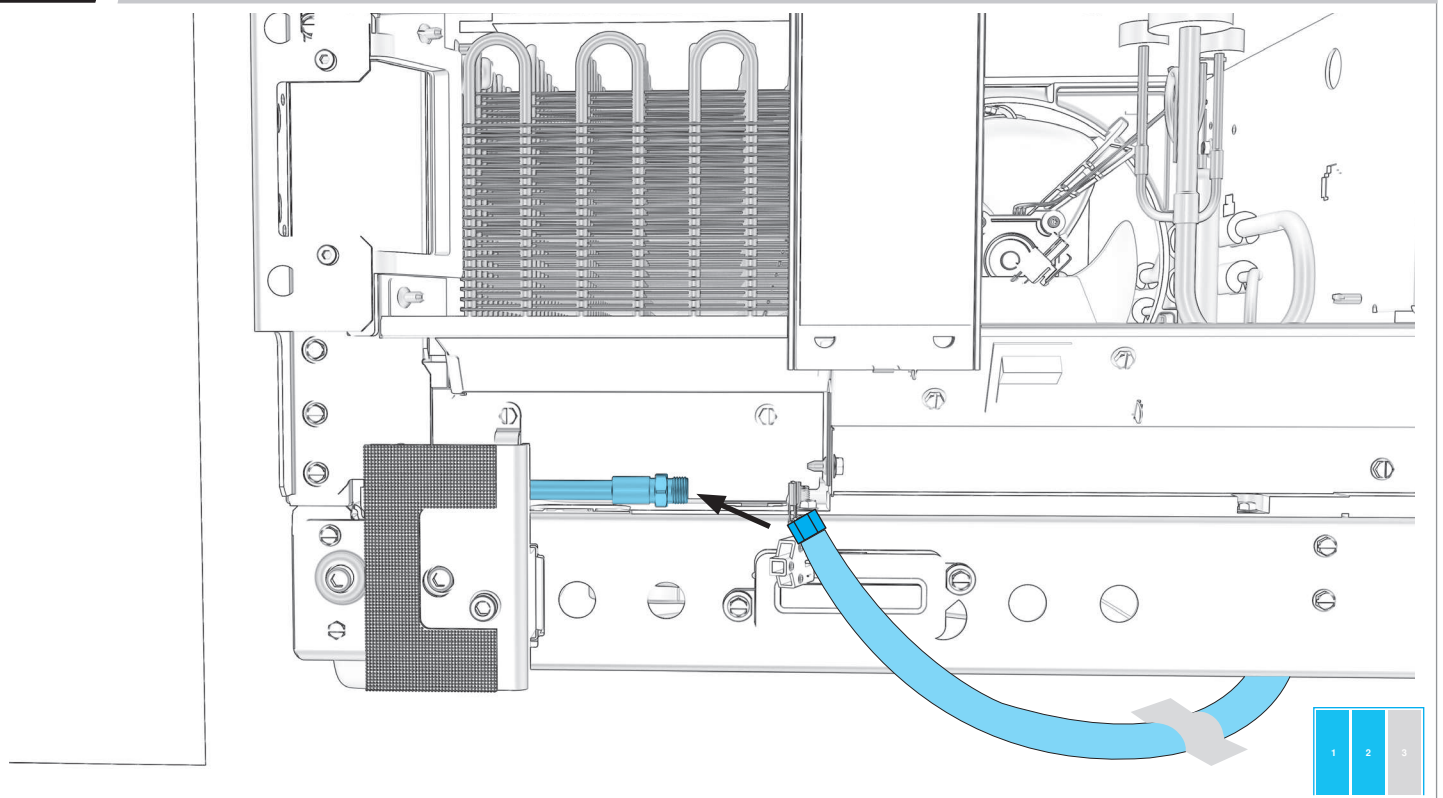

7.11

IF INSTALLING ONLY TWO COLUMNS:
GO TO SECTION 9



T H I R D
C O L U M N I N S T A L L A T I O N

8

THIRD COLUMN INSTALLATION

8.1

SECOND COLUMN: RAISE TO 84" LINE.

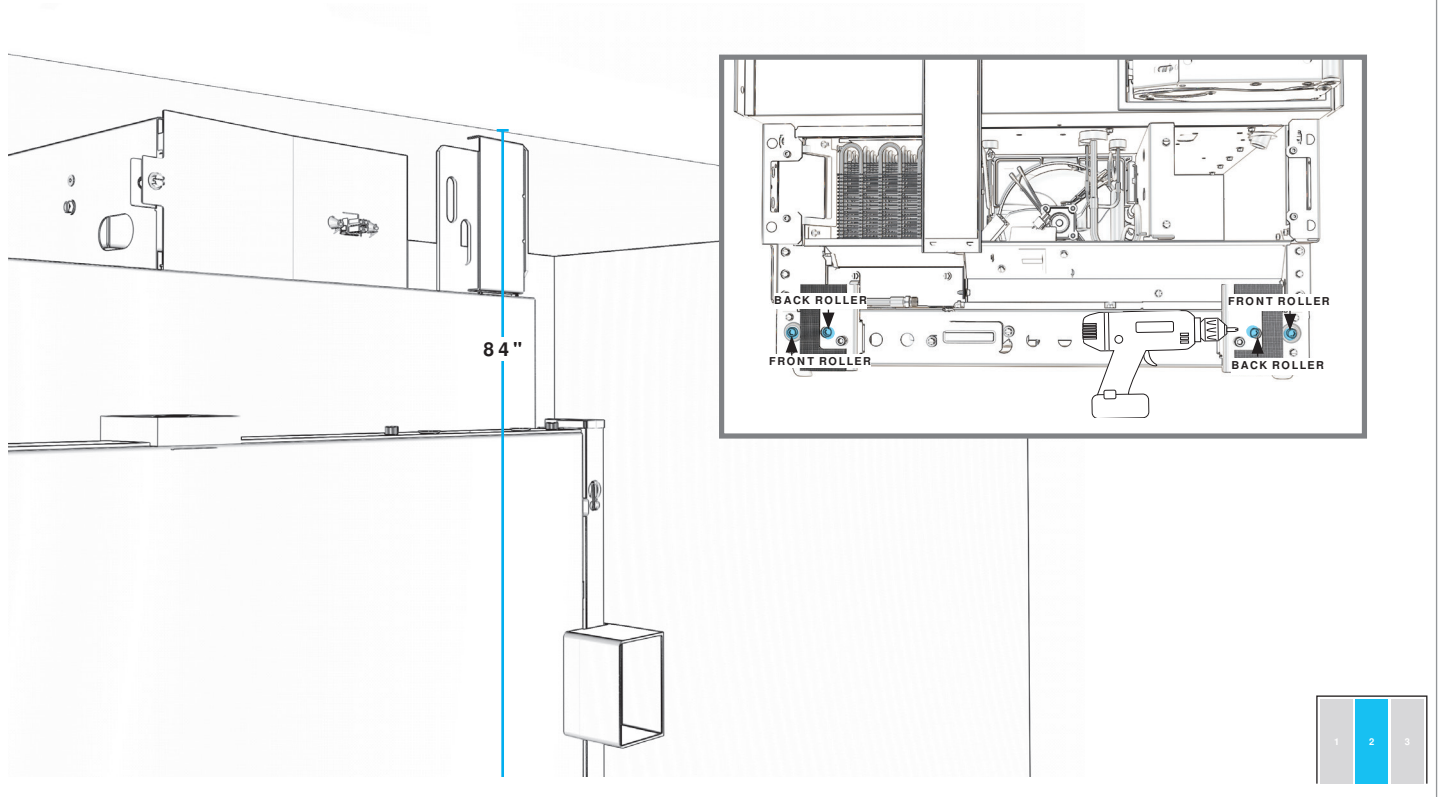

8.2

SECOND COLUMN: SECURE POSITIONING BRACKET.

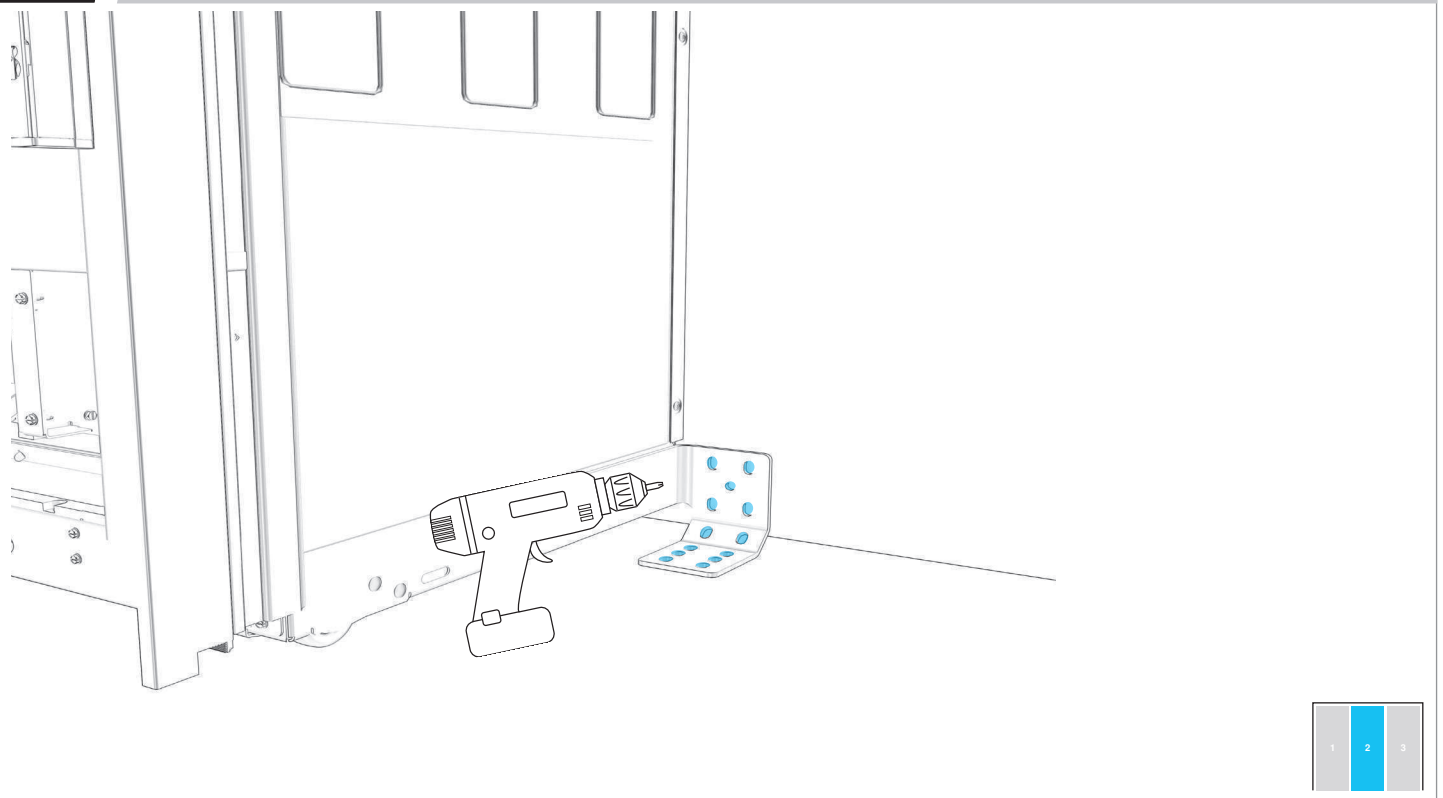

8.3

LOOSELY DRIVE SCREWS THROUGH INSTALLATION BRACKET AND BADASS SOFFIT BRACKET.

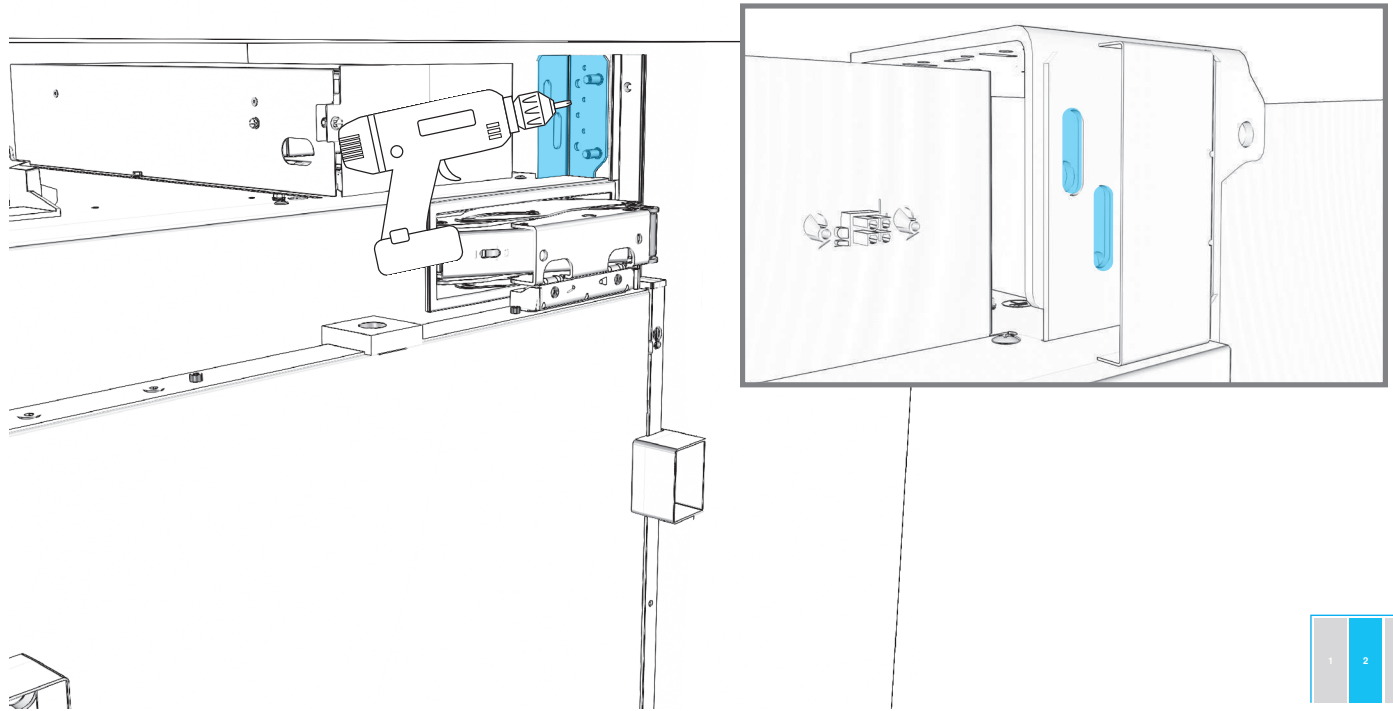

8.4

THIRD COLUMN: SWITCH OFF POWER.

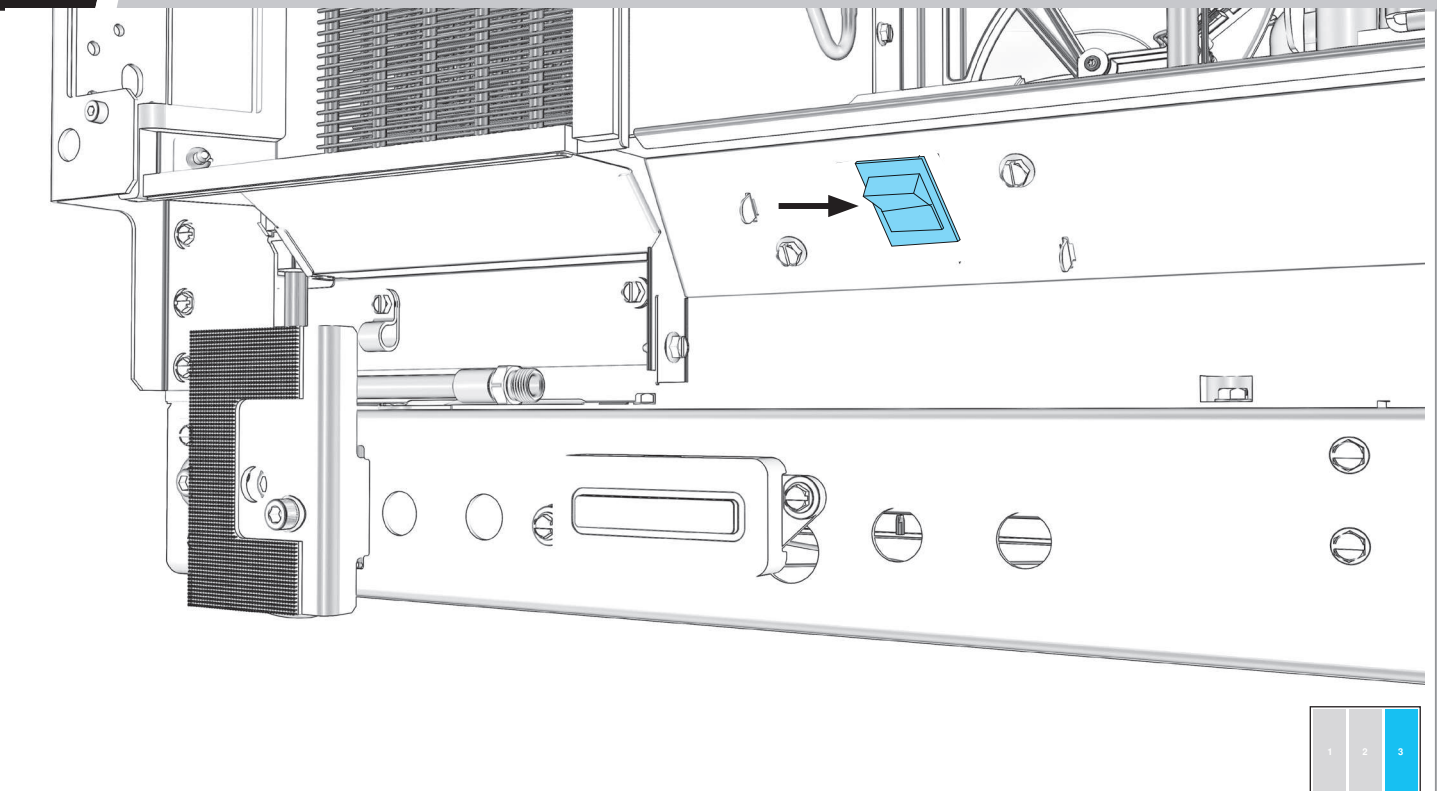

BEFORE PLUGGING IN COLUMN, READ WARNING.

⚠ WARNING



Electrical Shock Hazard

Plug into a grounded 3 prong outlet.

Do not remove ground prong.

Do not use an adapter.

Do not use an extension cord.

Failure to follow these instructions can result in death, fire, or electrical shock.

8.5

PLUG INTO GROUNDED 3 PRONG OUTLET.

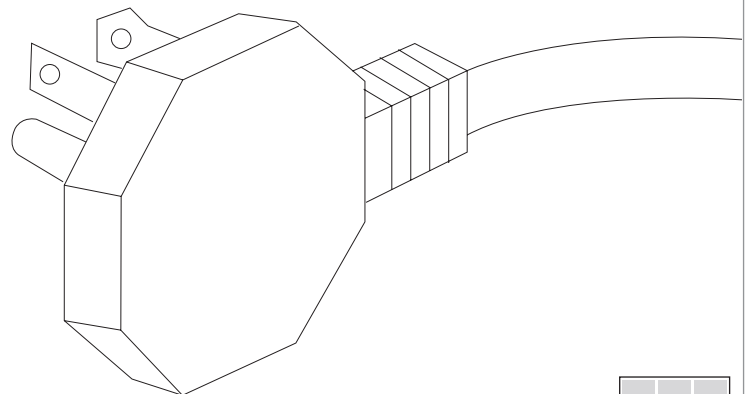
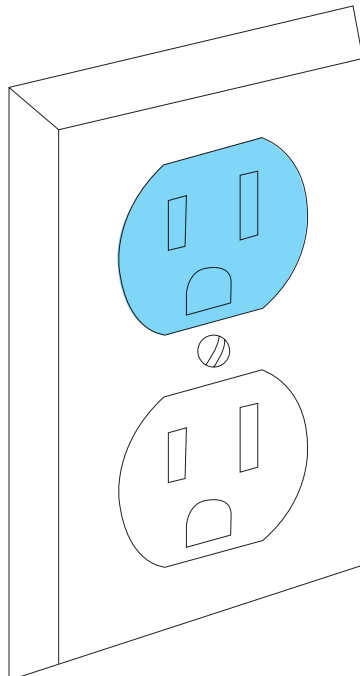

BEFORE MOVING COLUMN, READ ALL WARNINGS.

! WARNING



Tip Over Hazard

Refrigerator is top heavy and tips easily when not completely installed.

Keep doors taped closed until refrigerator is completely installed.

Use two or more people to move and install refrigerator.

Failure to do so can result in death or serious injury.

When Moving Your Refrigerator:

Your refrigerator is heavy. When moving the refrigerator for cleaning or service, be sure to cover the floor with cardboard or hardboard to avoid floor damage. Always pull the refrigerator straight out when moving it. Do not wiggle or “walk” the refrigerator when trying to move it, as floor damage could occur.

Important information to know about glass shelves and covers:

Do not clean glass shelves or covers with warm water when they are cold. Shelves and covers may break if exposed to sudden temperature changes or impact, such as bumping. Tempered glass is designed to shatter into many small, pebble-size pieces. This is normal. Glass shelves and covers are heavy. Use both hands when removing them to avoid dropping.

8.7

THIRD COLUMN: MOVE INTO THE CUTOUT.

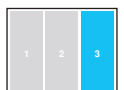
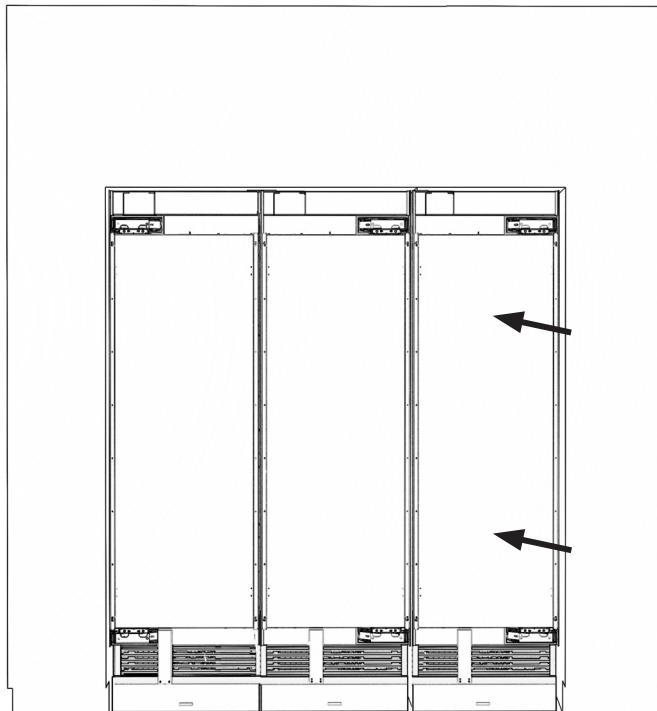

8

THIRD COLUMN INSTALLATION

8.8

THIRD COLUMN: RAISE TO 84" LINE.

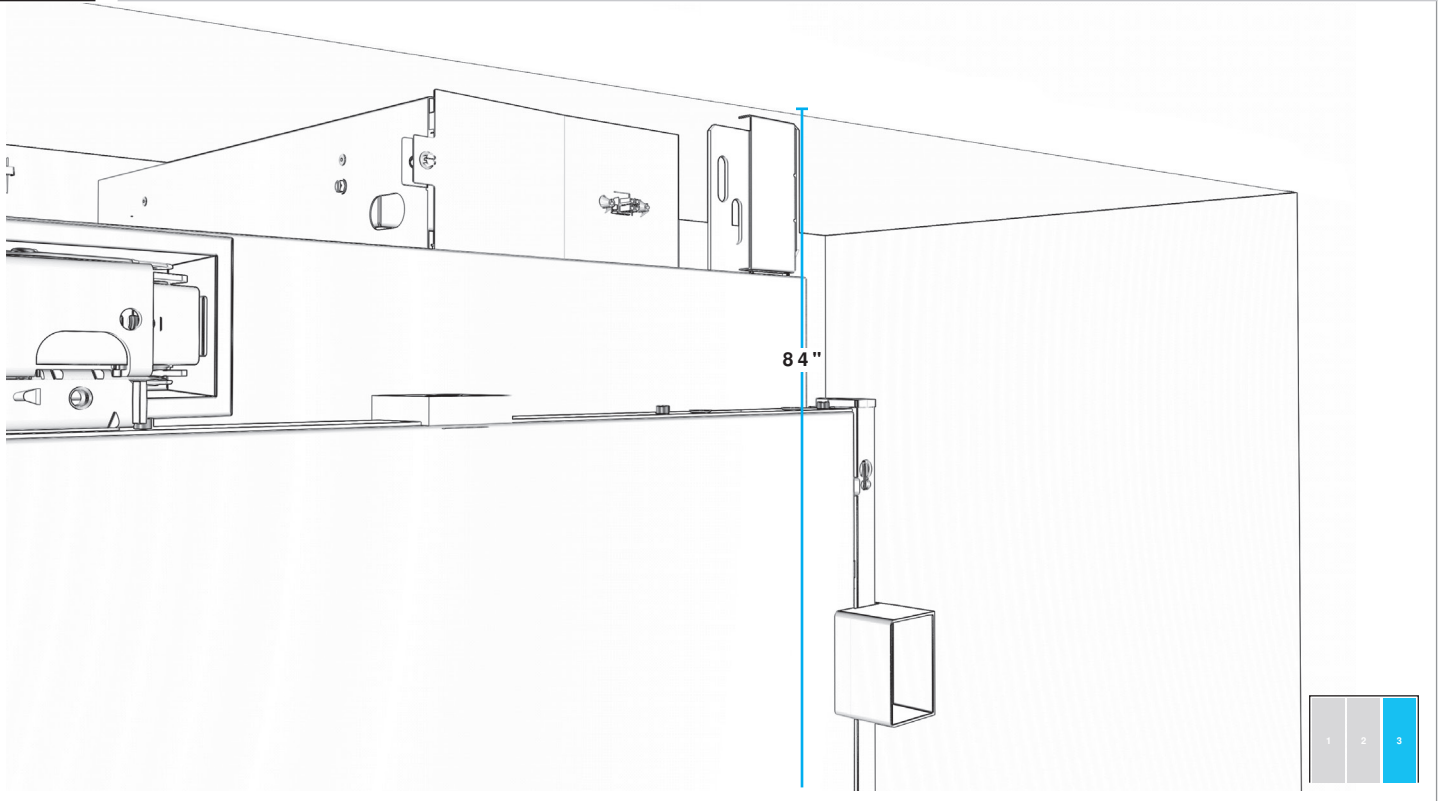

8.9

SECURE SECOND UNIT TO THIRD UNIT AT TOP.

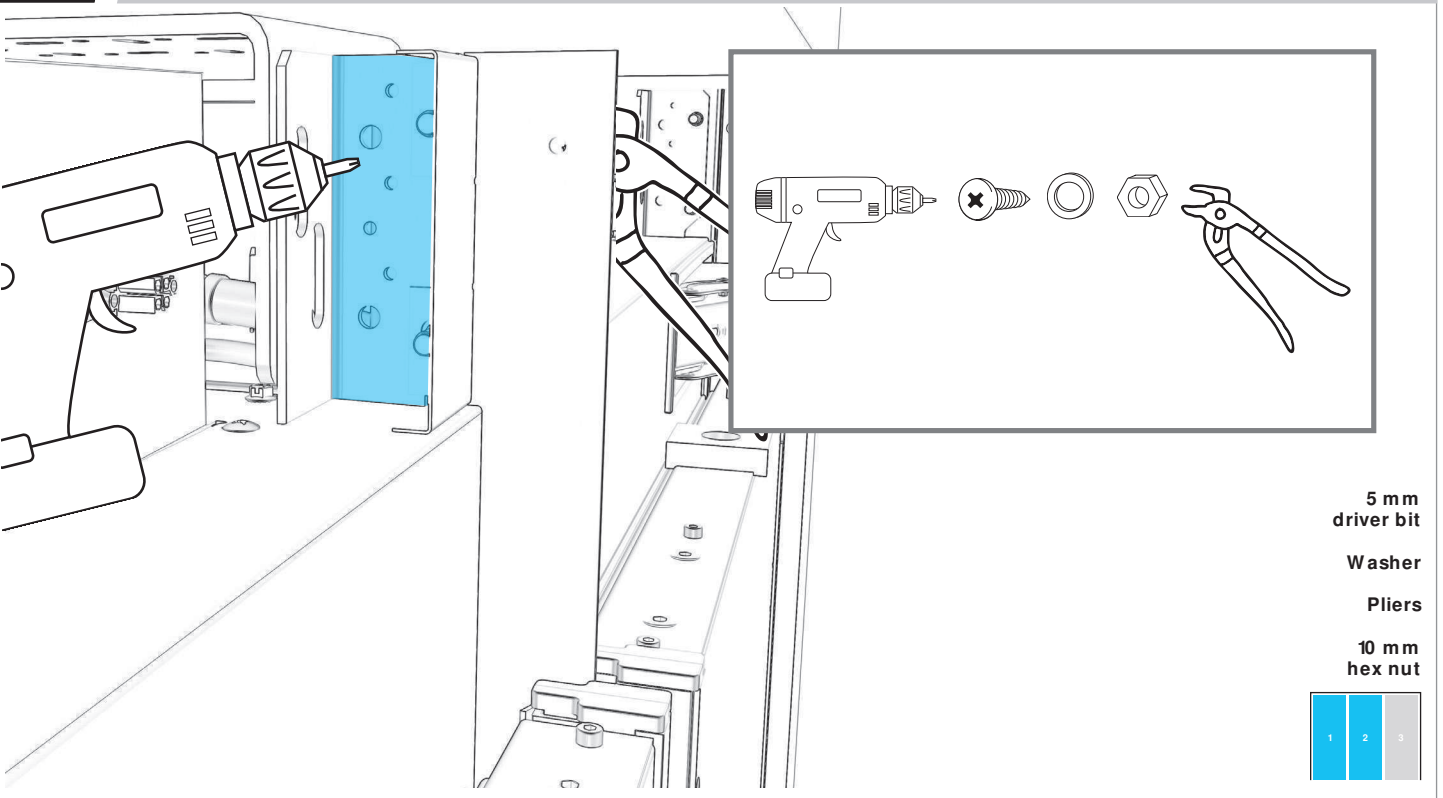

5 mm
driver bit

Washer

Pliers

10 mm
hex nut

8.10 REPEAT ON BOTTOM BRACKET.

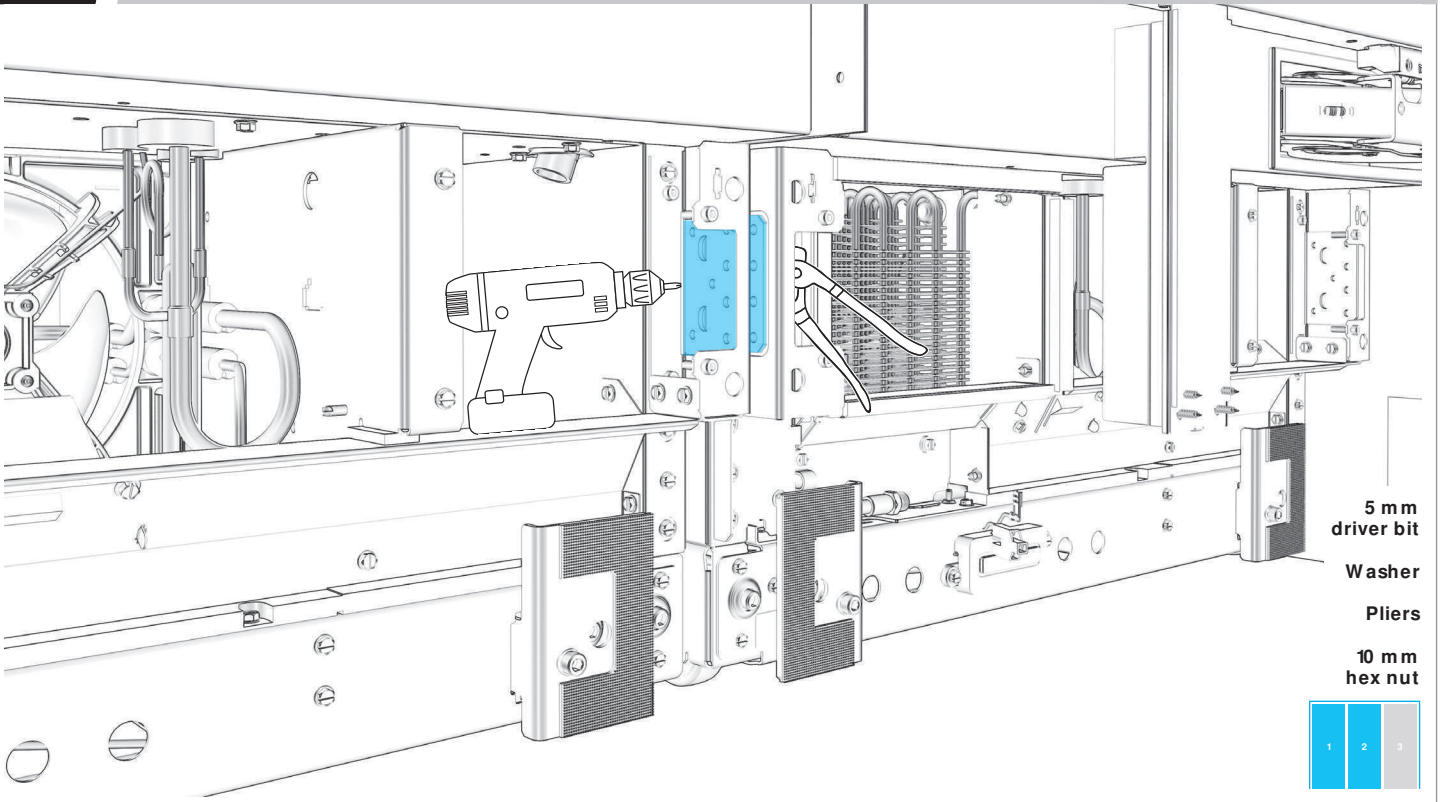

8.11 THIRD COLUMN : SECURE TO RIGHT SIDE PANEL.

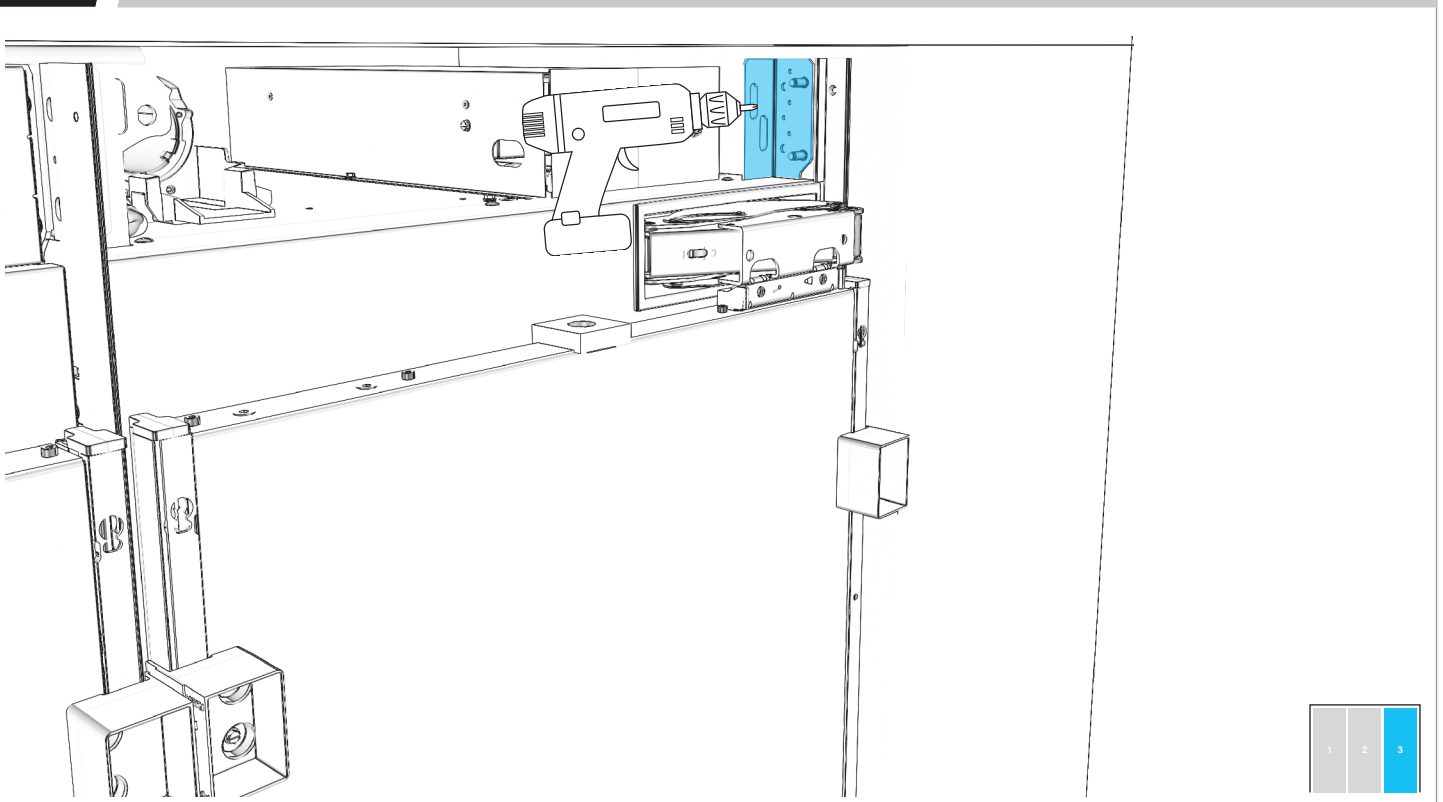

8

THIRD COLUMN INSTALLATION

8.12

THIRD COLUMN: REPEAT ON BOTTOM BRACKET.

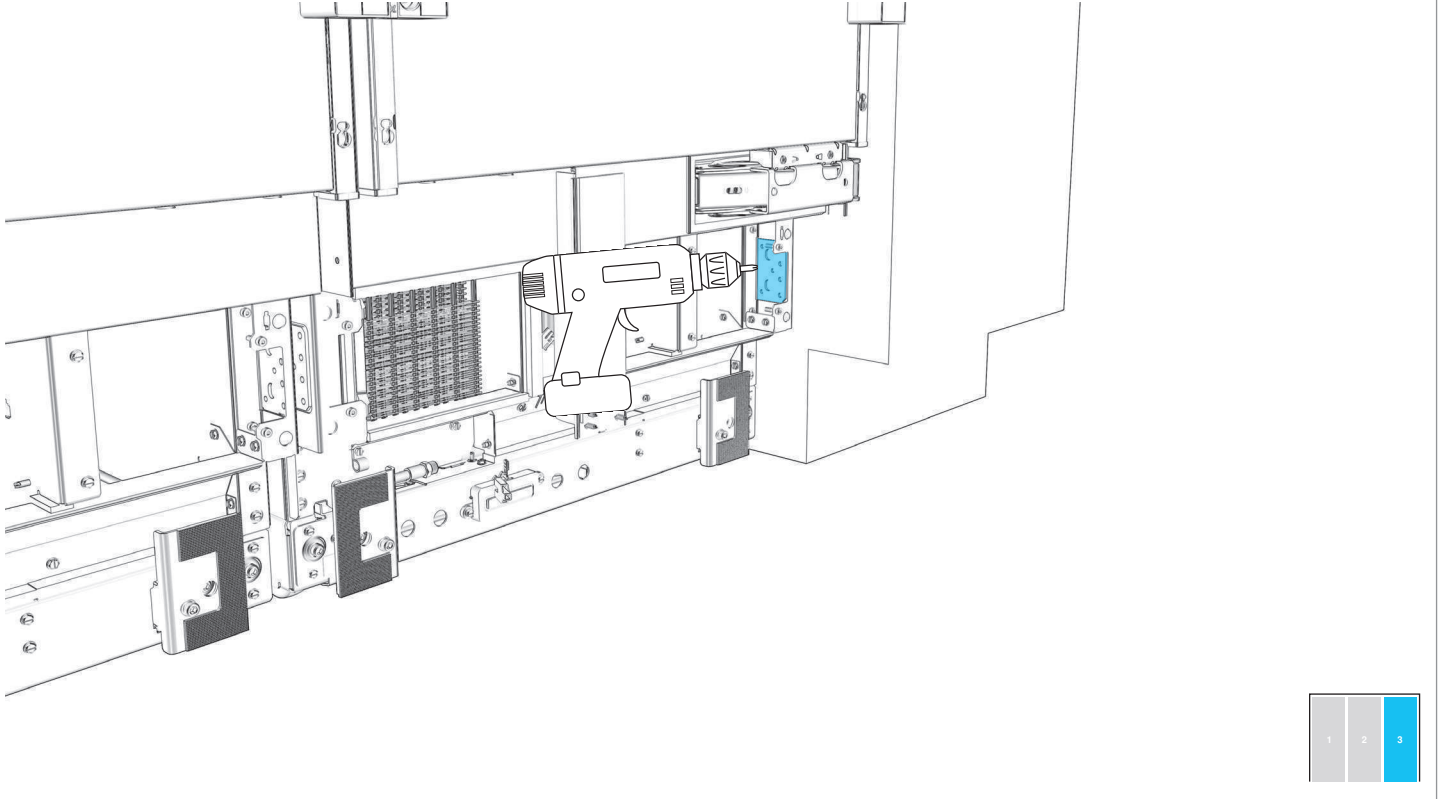

8.13

CONNECT THE WATER SUPPLY LINE.

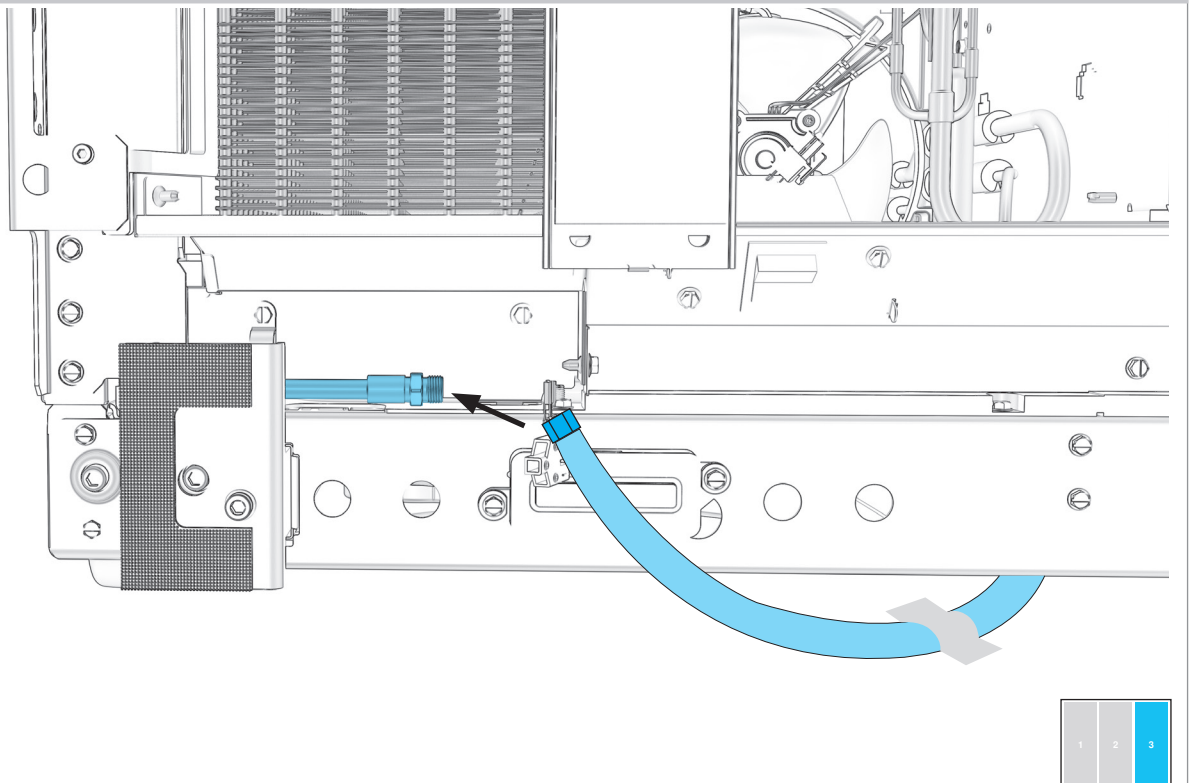

P R E P A R E

C O L U M N S F O R U S E

9

PREPARE COLUMNS FOR USE

9.1

EACH COLUMN: ALIGN FILTER HOUSING BETWEEN BRACKETS ON TOP OF COLUMN.

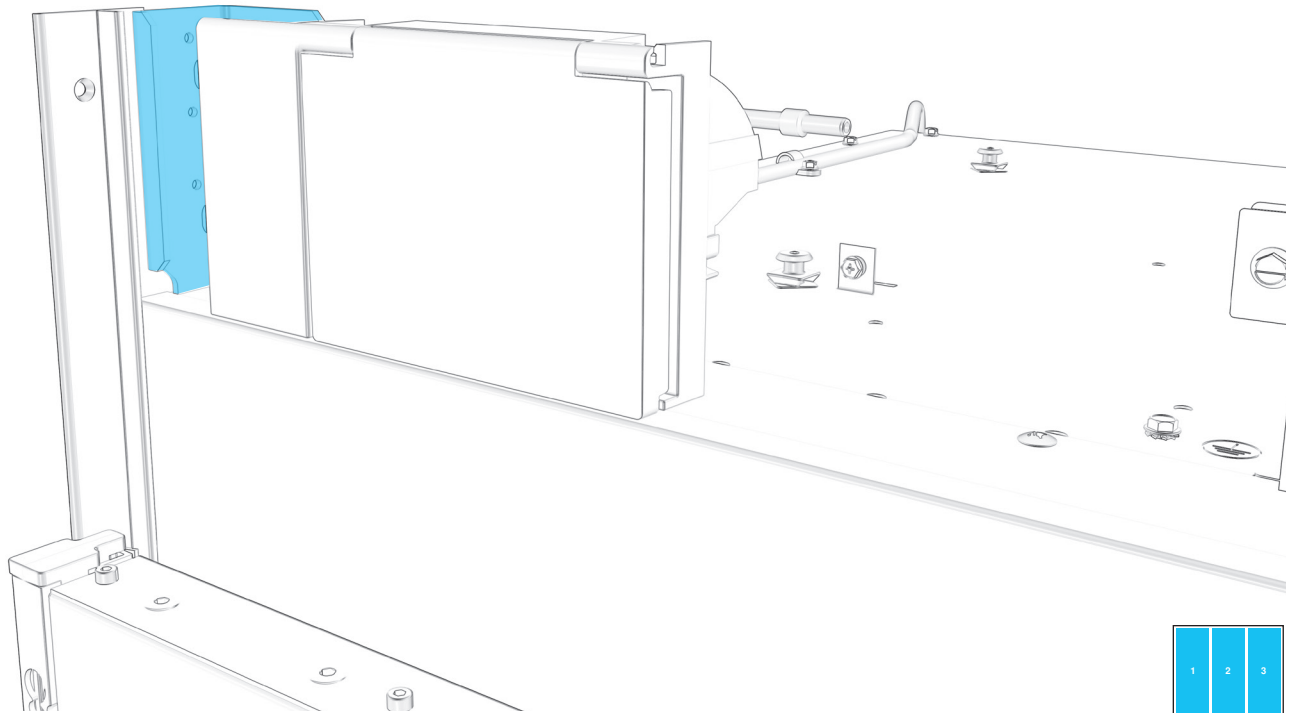

9.2

EACH COLUMN: REINSTALL HOUSING, PUSHING LEFT WITH FORCE.

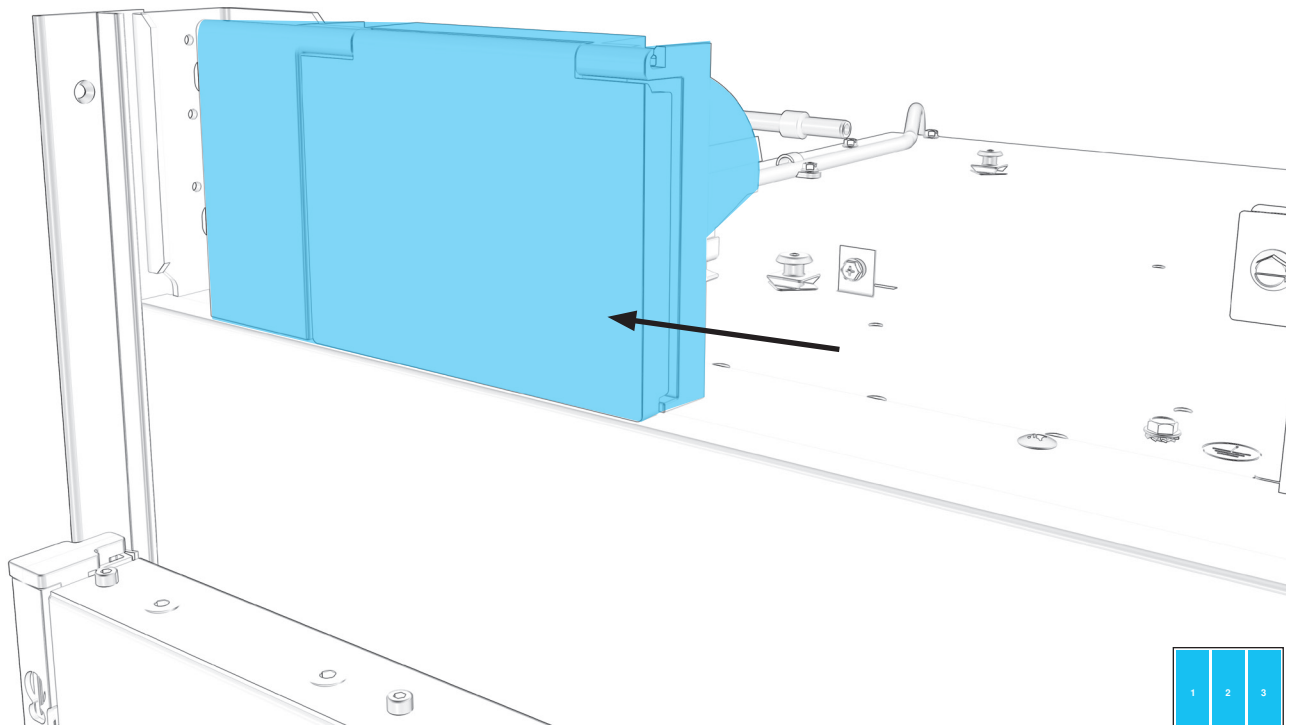

9.3 EACH COLUMN: INSERT WATER FILTER UNTIL SEATED.

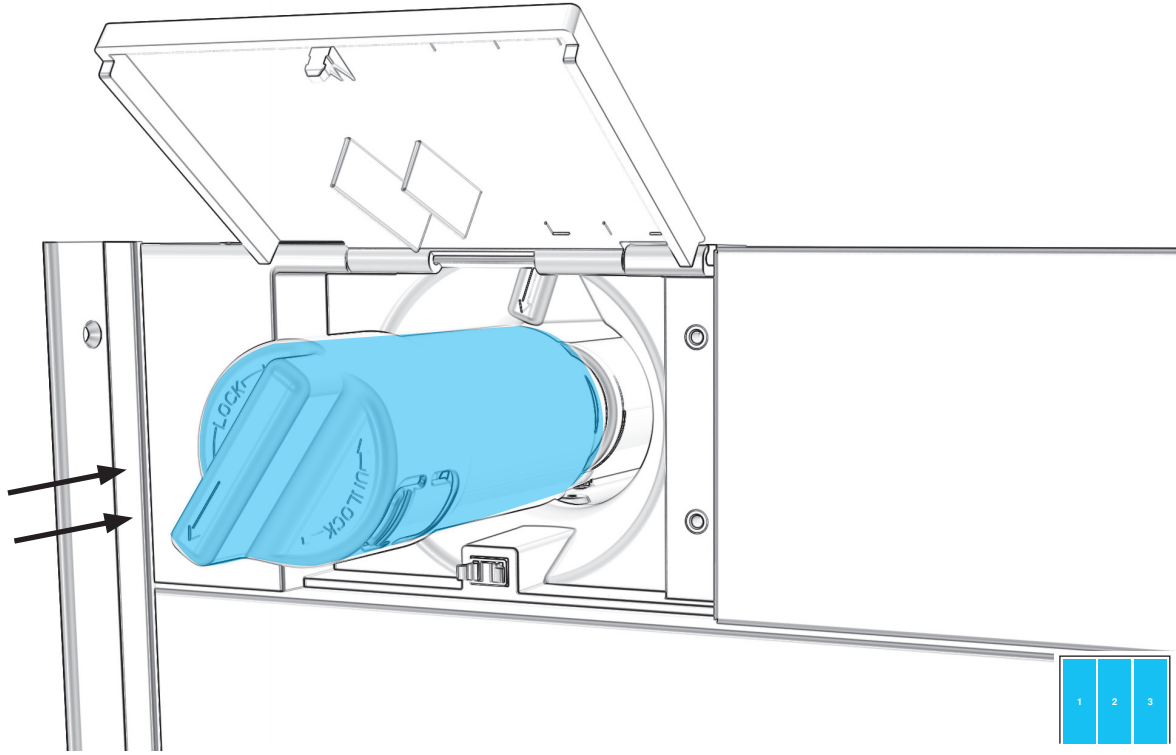

9.4 EACH COLUMN: ROTATE FILTER CLOCKWISE TO ALIGN ARROWS.

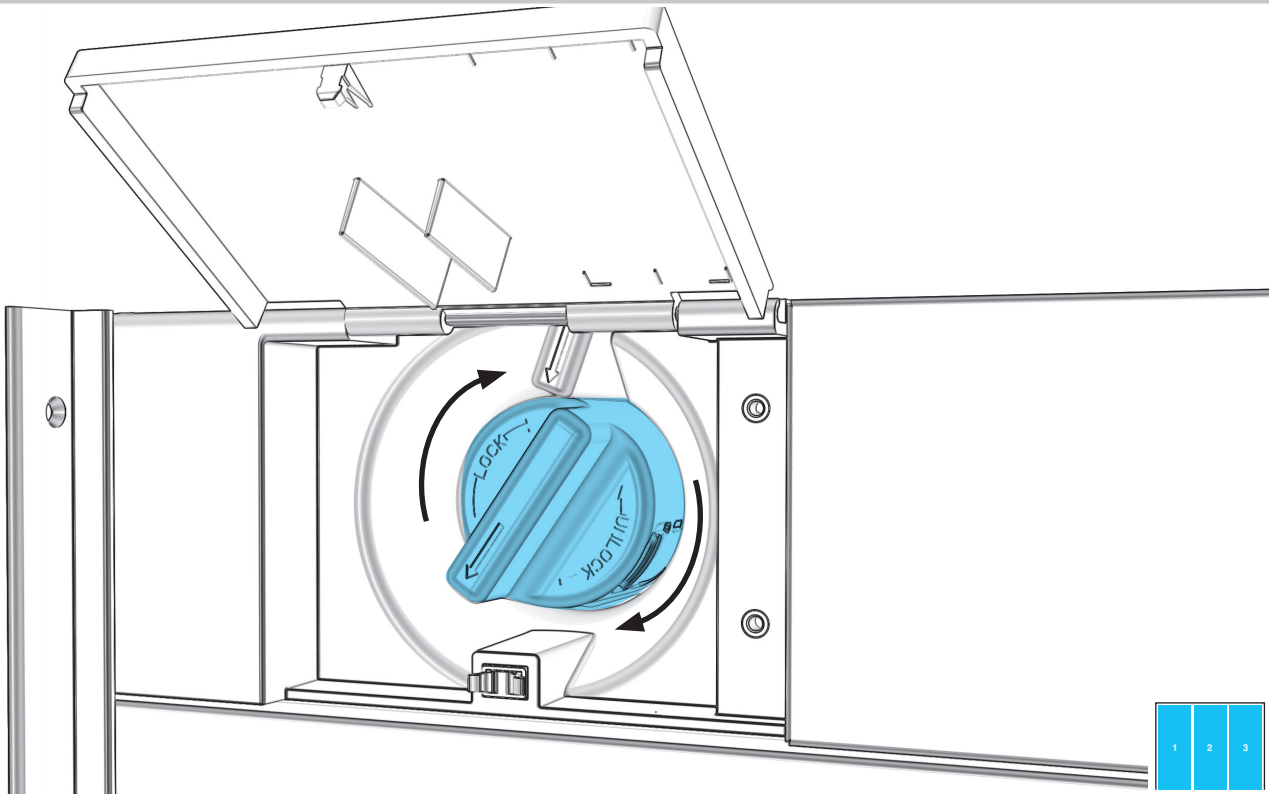

9

PREPARE COLUMNS FOR USE

9.5

EACH COLUMN: SECURE WITH TWO SCREWS AND REPLACE TOP COVER.

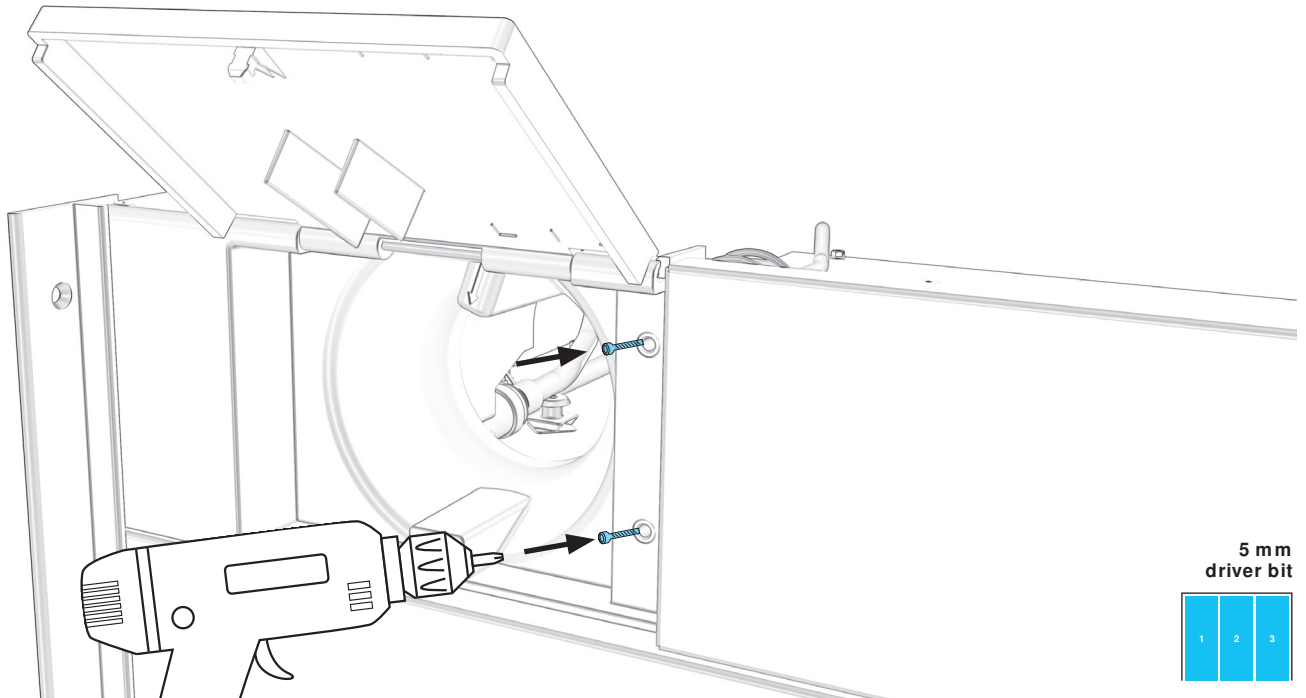

9.6

EACH COLUMN: REINSTALL AIR GRILLE.

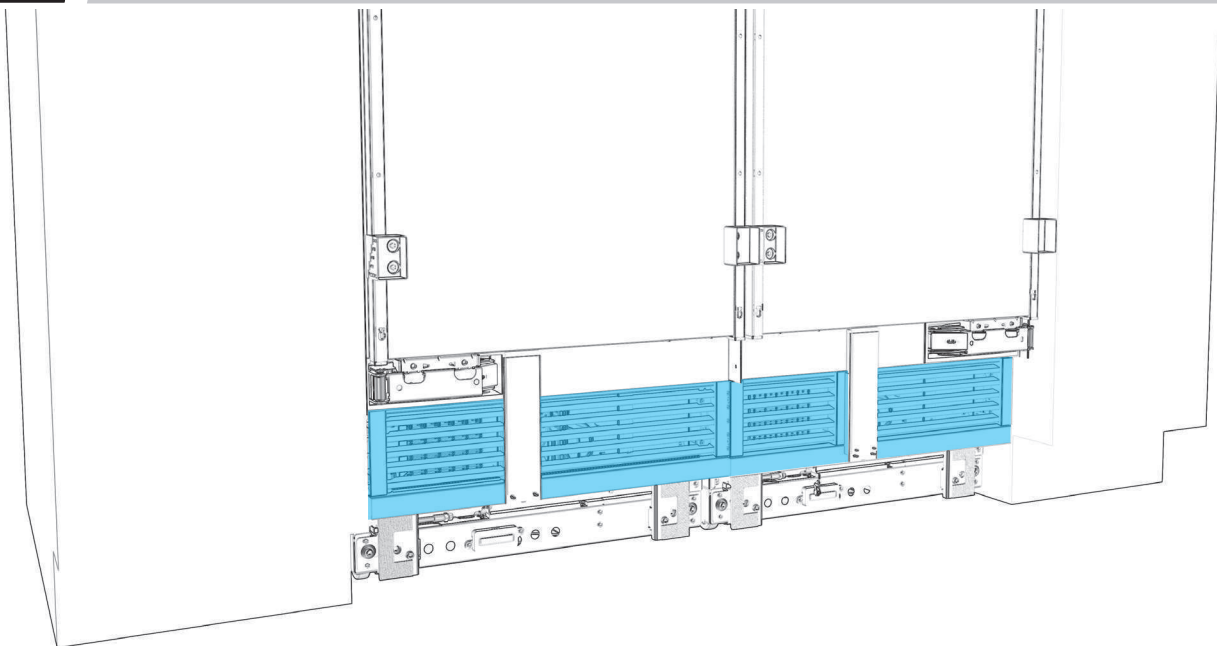

9.7

EACH COLUMN: TURN POWER ON

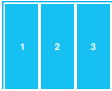
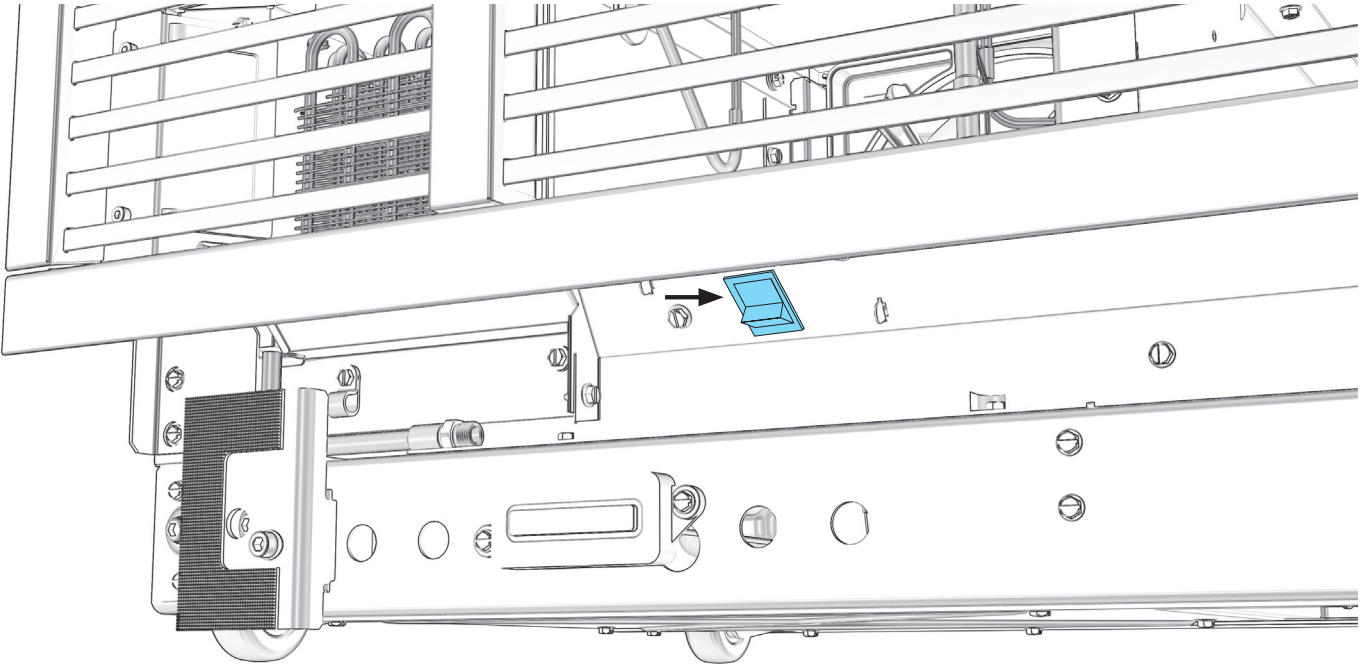

CHECKPOINT

INSTALLATION CHECKPOINT

PG.86 CUSTOM WOOD

TOE KICK PREPARATION

PG.89 STAINLESS STEEL

TOE KICK PREPARATION

PG.92 ALIGN AND INSTALL ALL TOE KICKS

T O E - K N C K

CUSTOM WOOD PREPARATION

10

TOE KICK: CUSTOM WOOD PREPARATION

10.1

MEASURE AND MARK CENTERLINE OF TOE KICK.

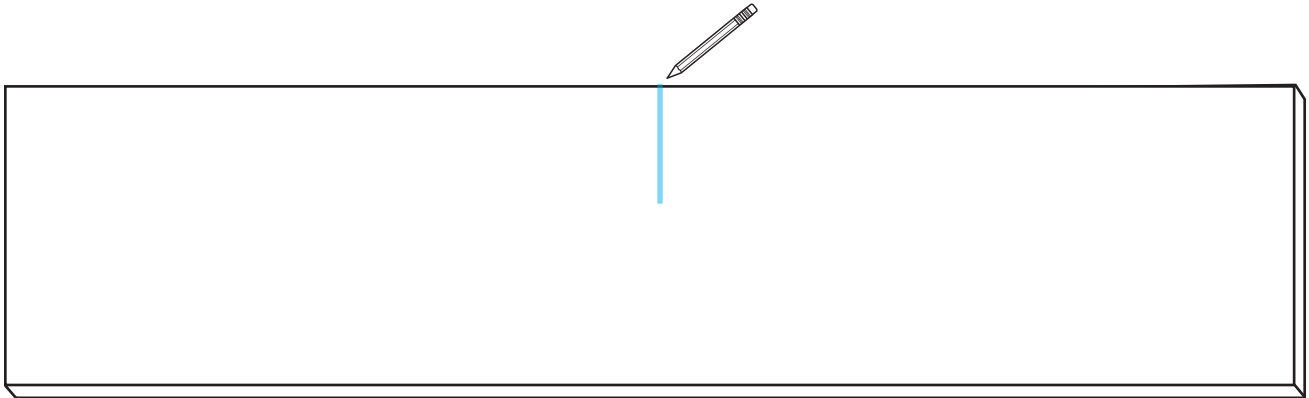

COMPLETE ALL STEPS FOR EACH UNIT.

10.2

ALIGN TEMPLATE

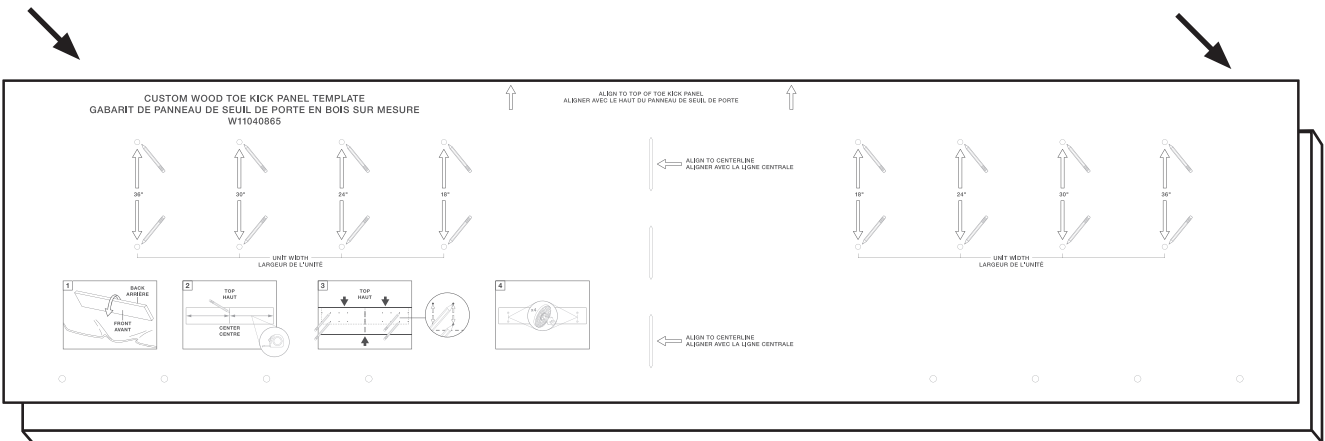

10.3 MARK GRIPPING PAD LOCATIONS.

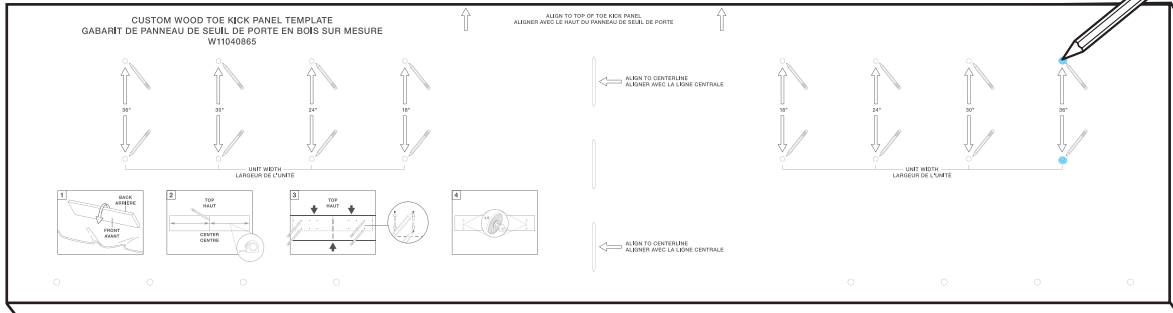

10.5 ADHERE GRIPPING PADS TO POINTS.

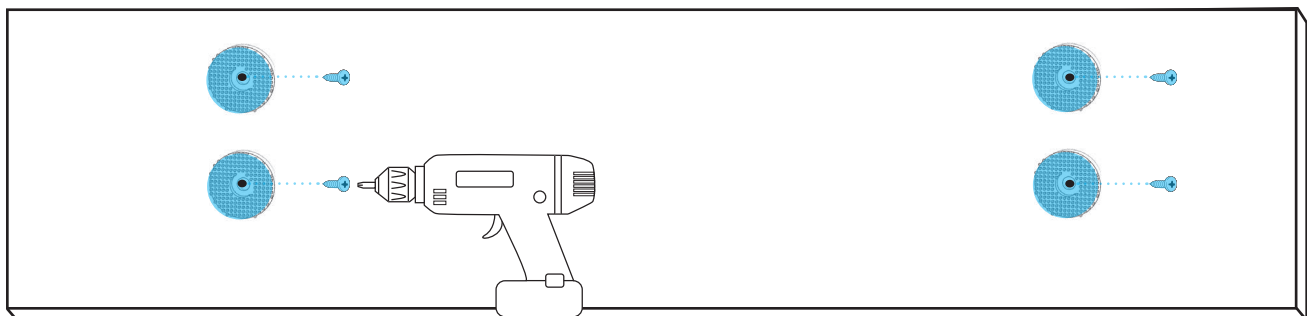

1	2	3
---	---	---

1	2	3
---	---	---

TOE-KICK

STAINLESS STEEL PREPARATION

11.1

EACH COLUMN: UNSCREW AND DISCARD WIFI HARNESS.

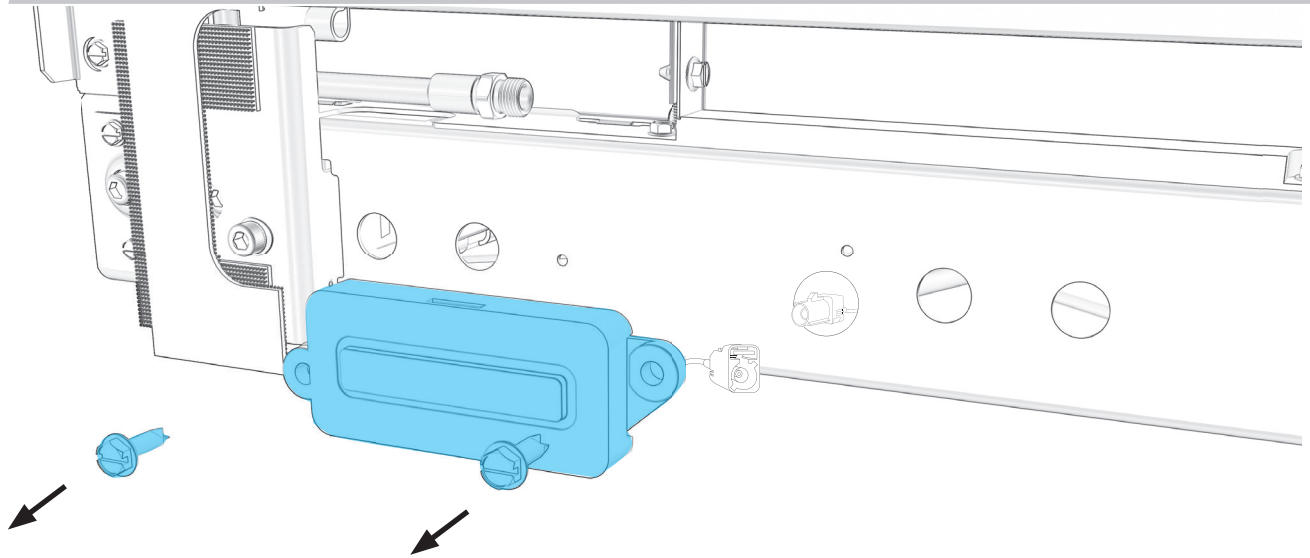

11.2

DISCONNECT BLUE WIFI WIRE FROM HARNESS.

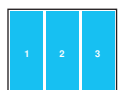
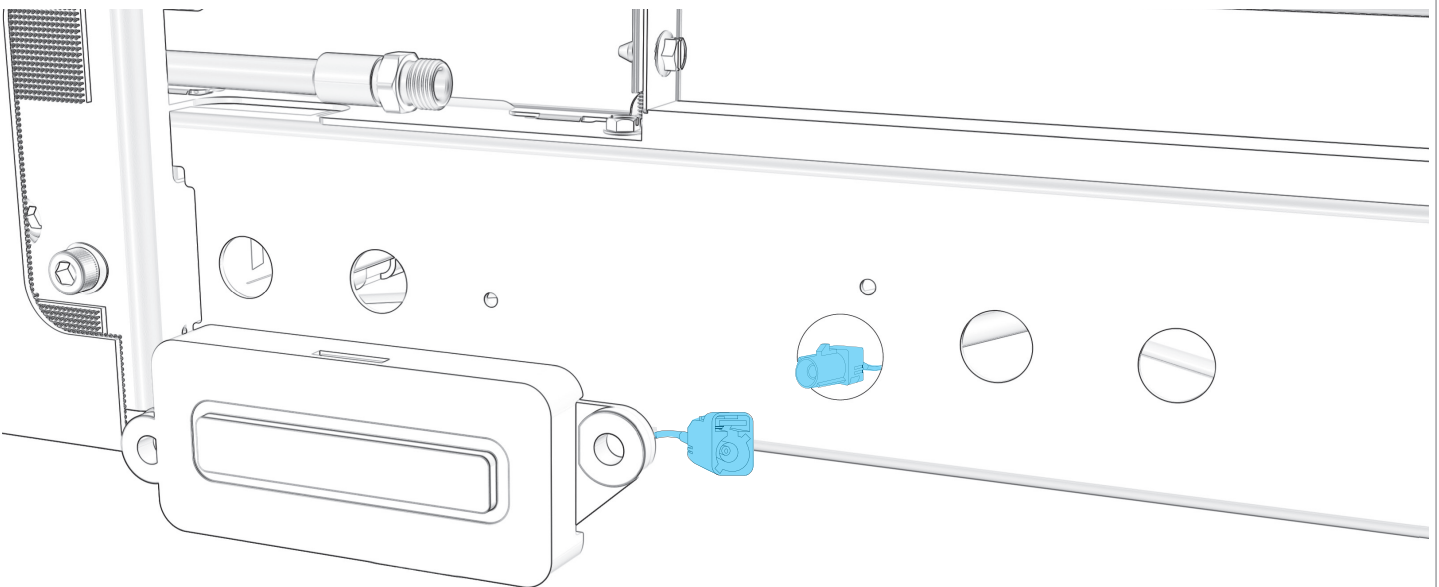

11

TOE KICK: STAINLESS STEEL PREPARATION

11.3

ATTACH BLUE TOE KICK AND COLUMN WIRES.

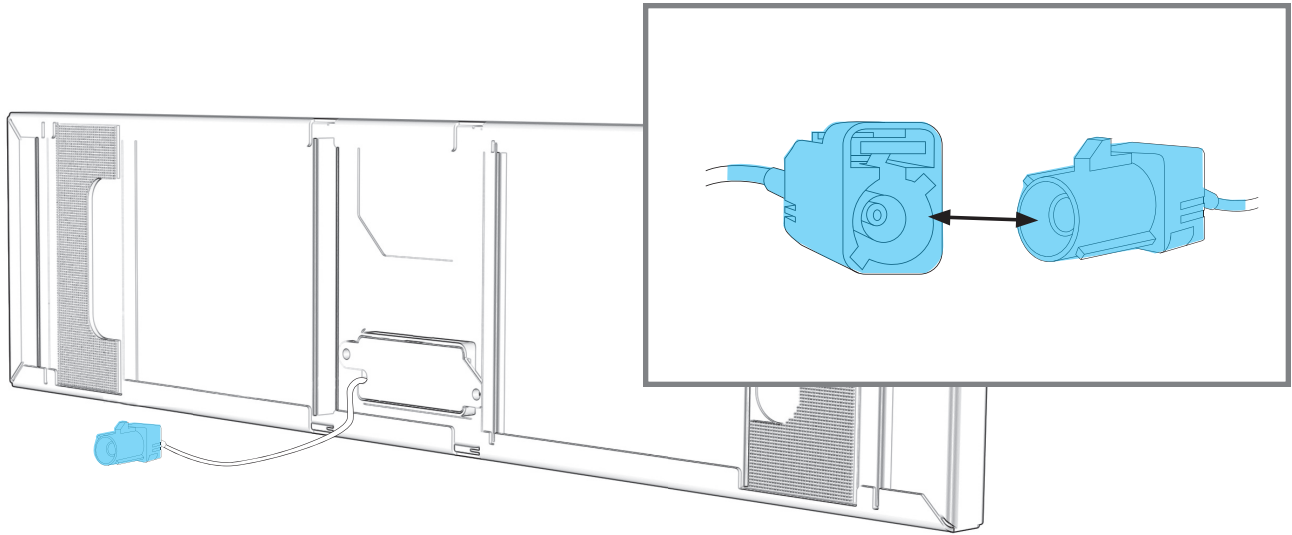

T O E - K I C K

ALIGN AND INSTALL

12

TOE KICK: ALIGN AND INSTALL

12.1

ALIGN TOE KICK BRACKETS WITH FURNITURE TOE KICK.

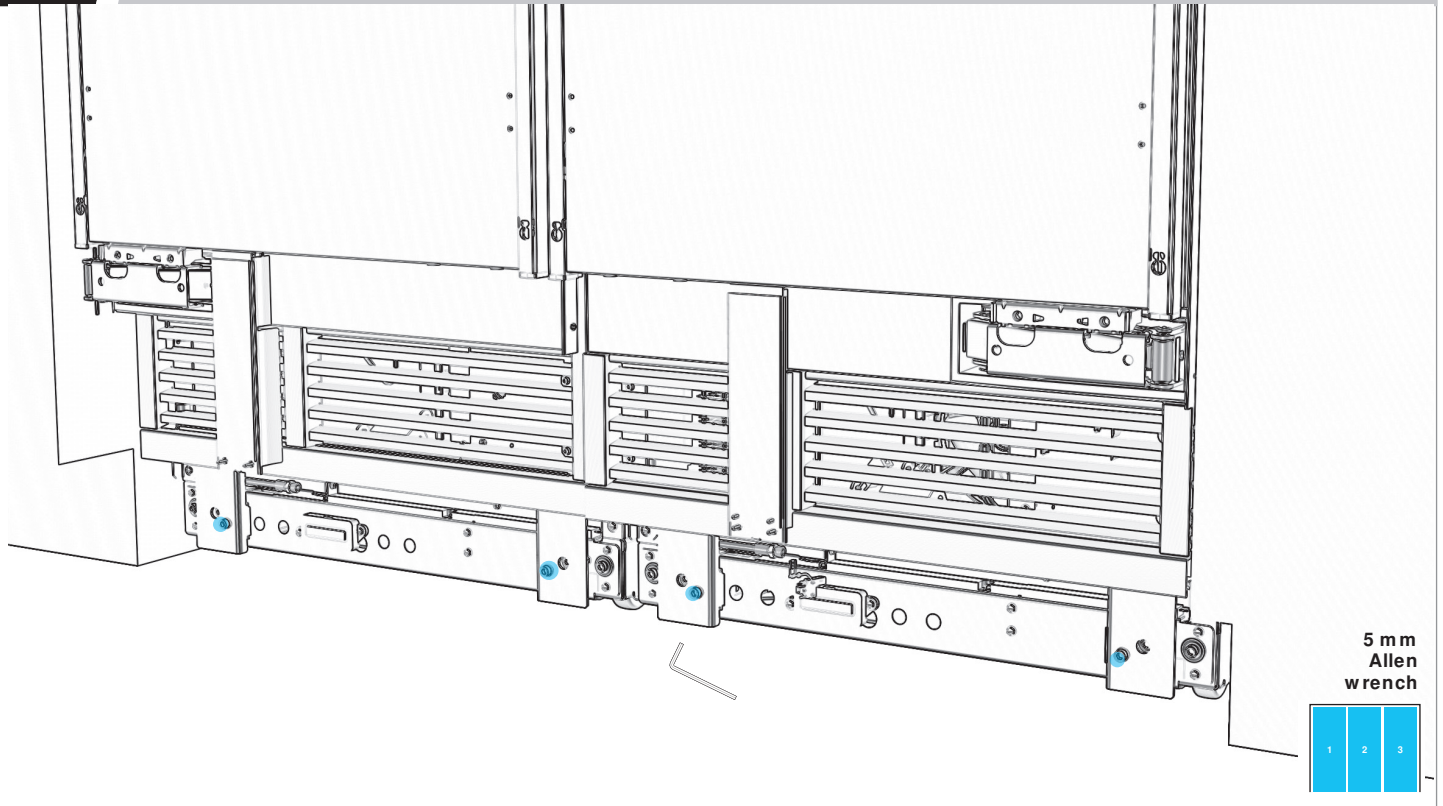

12.2

CHECK THAT BRACKETS ARE IN PLANE.

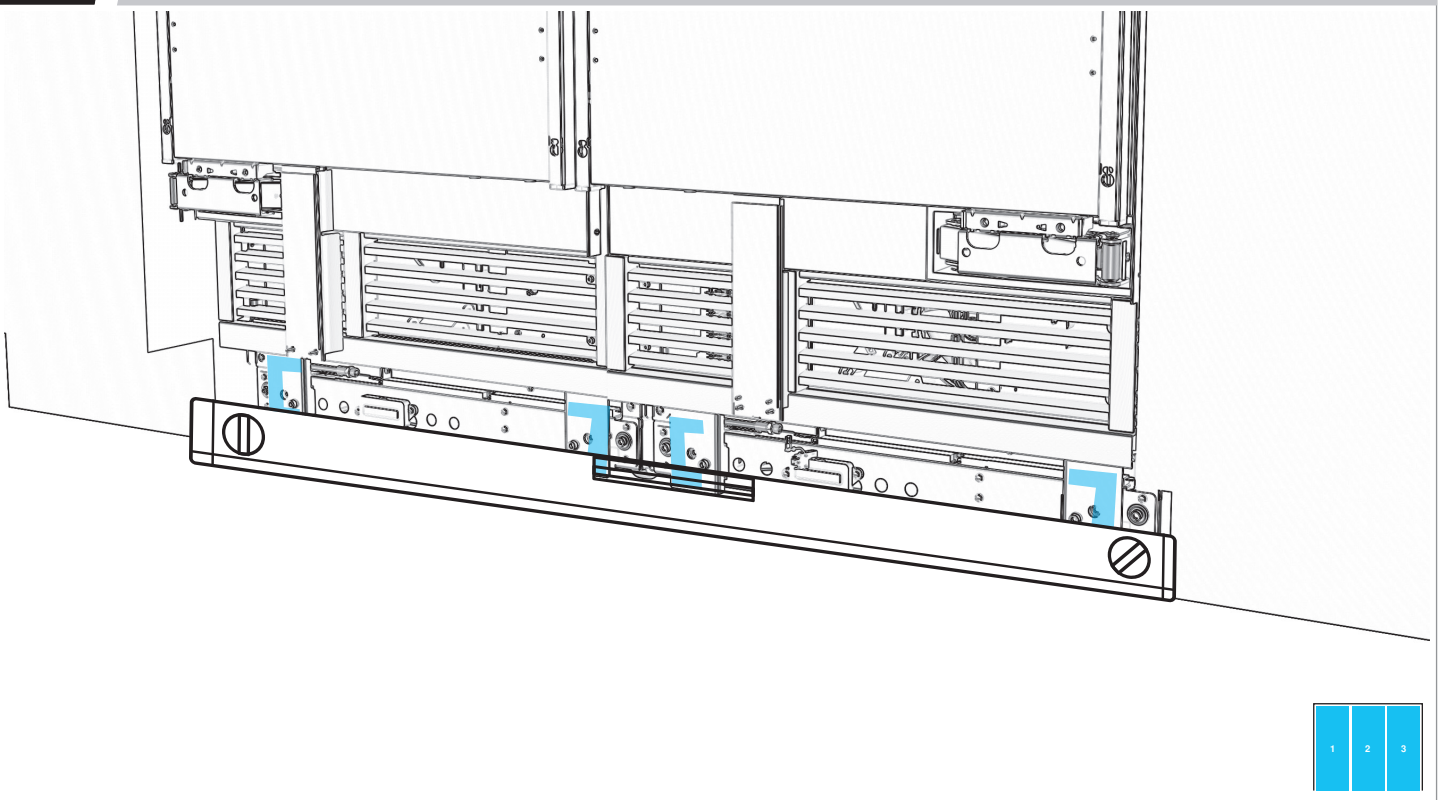

12.3 ALIGN TOE KICK GRIPPING PADS WITH BRACKETS.

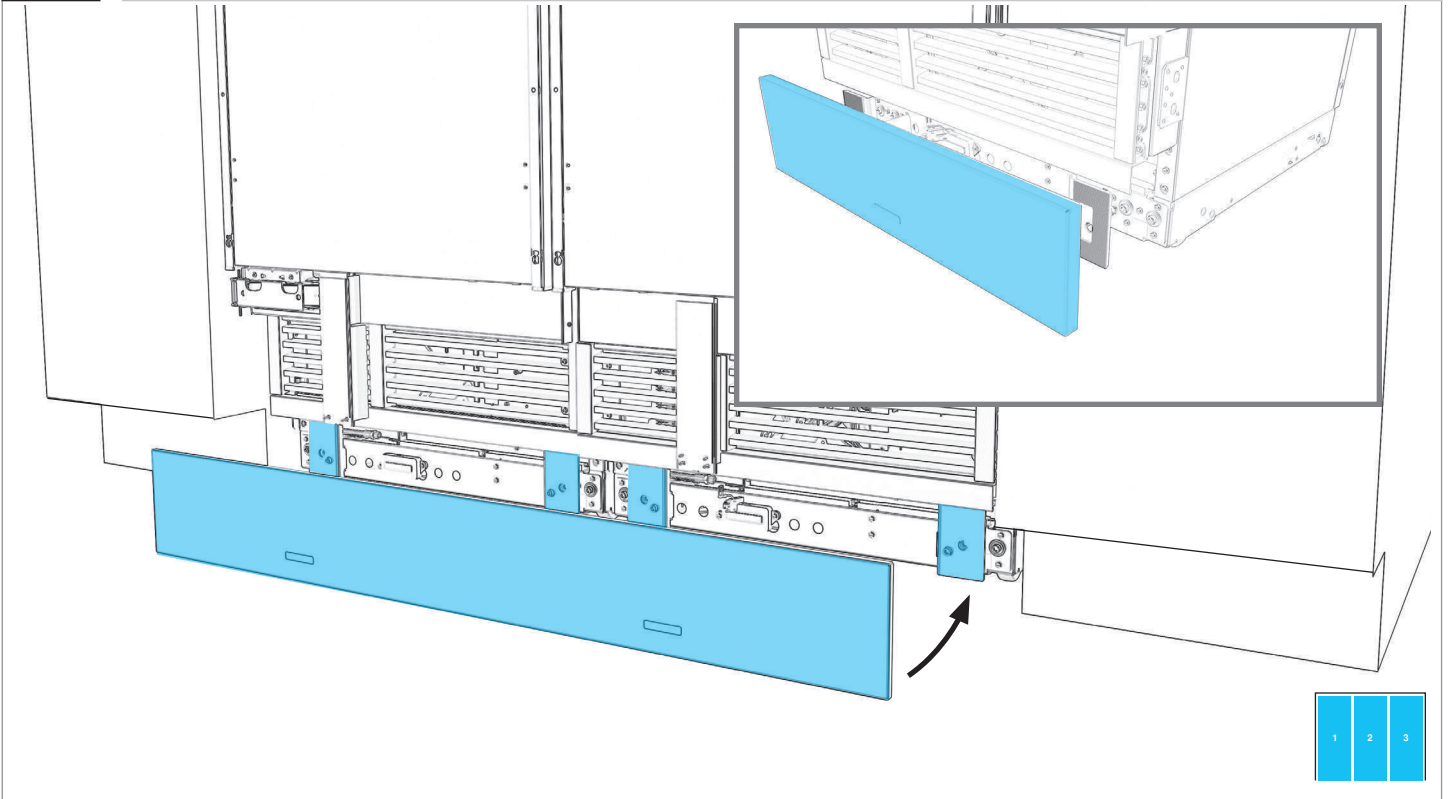

12.4 PRESS FIRMLY TO ATTACH.

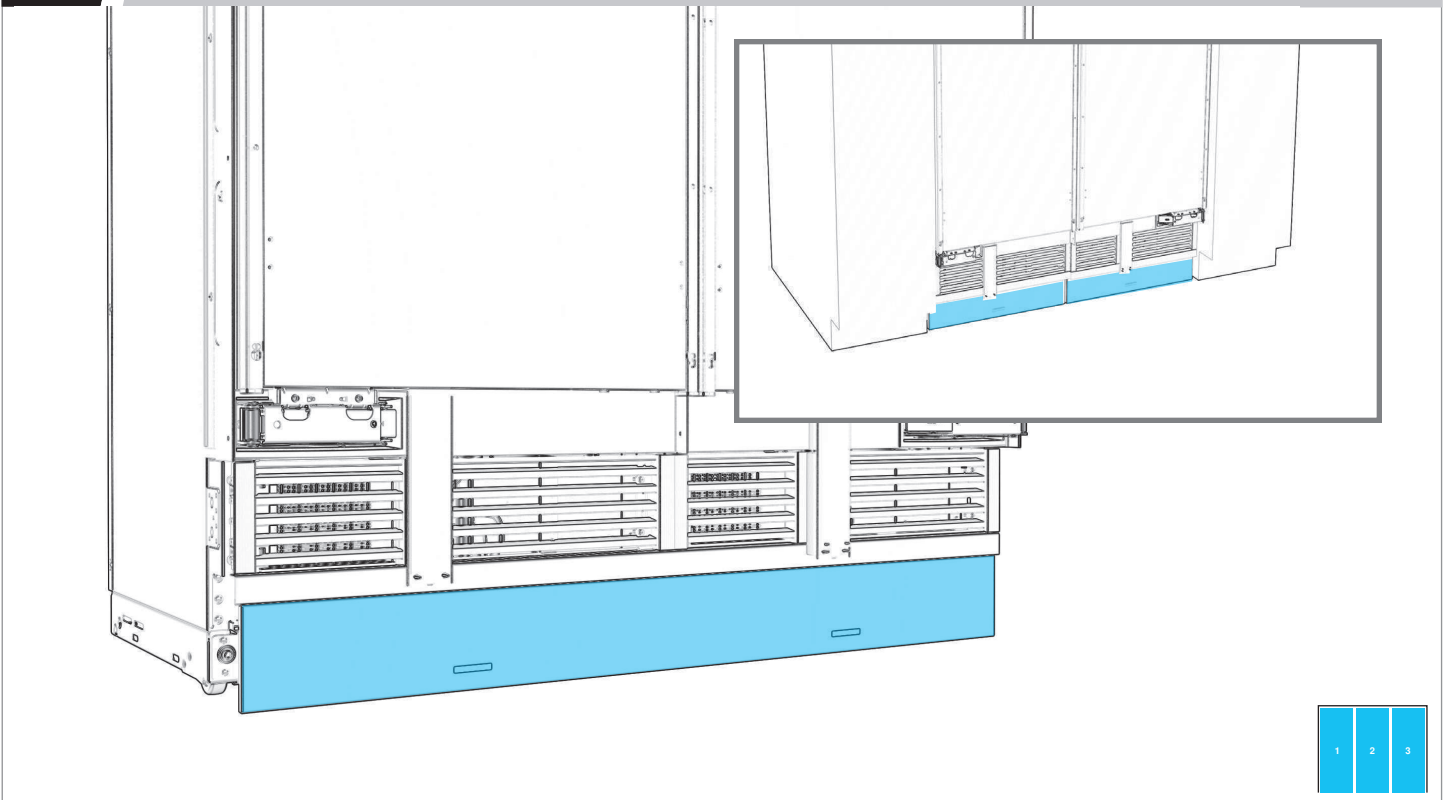

12

TOE KICK: ALIGN AND INSTALL

12.5

MEASURE OFFSET. IF UNEVEN, REMOVE TOE KICK.

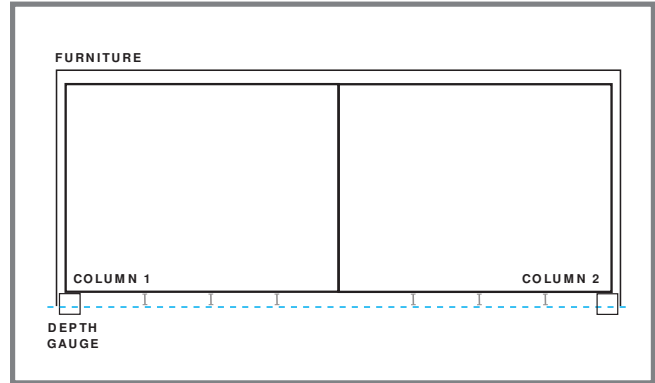
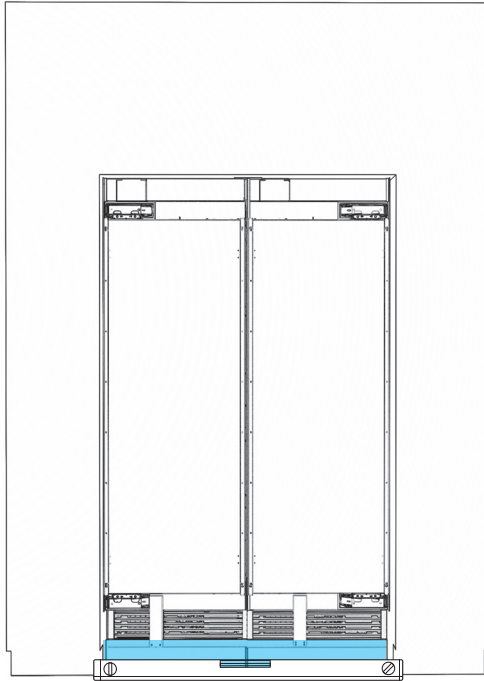

12.6

ADJUST BRACKETS TO ALIGN TOE KICK.

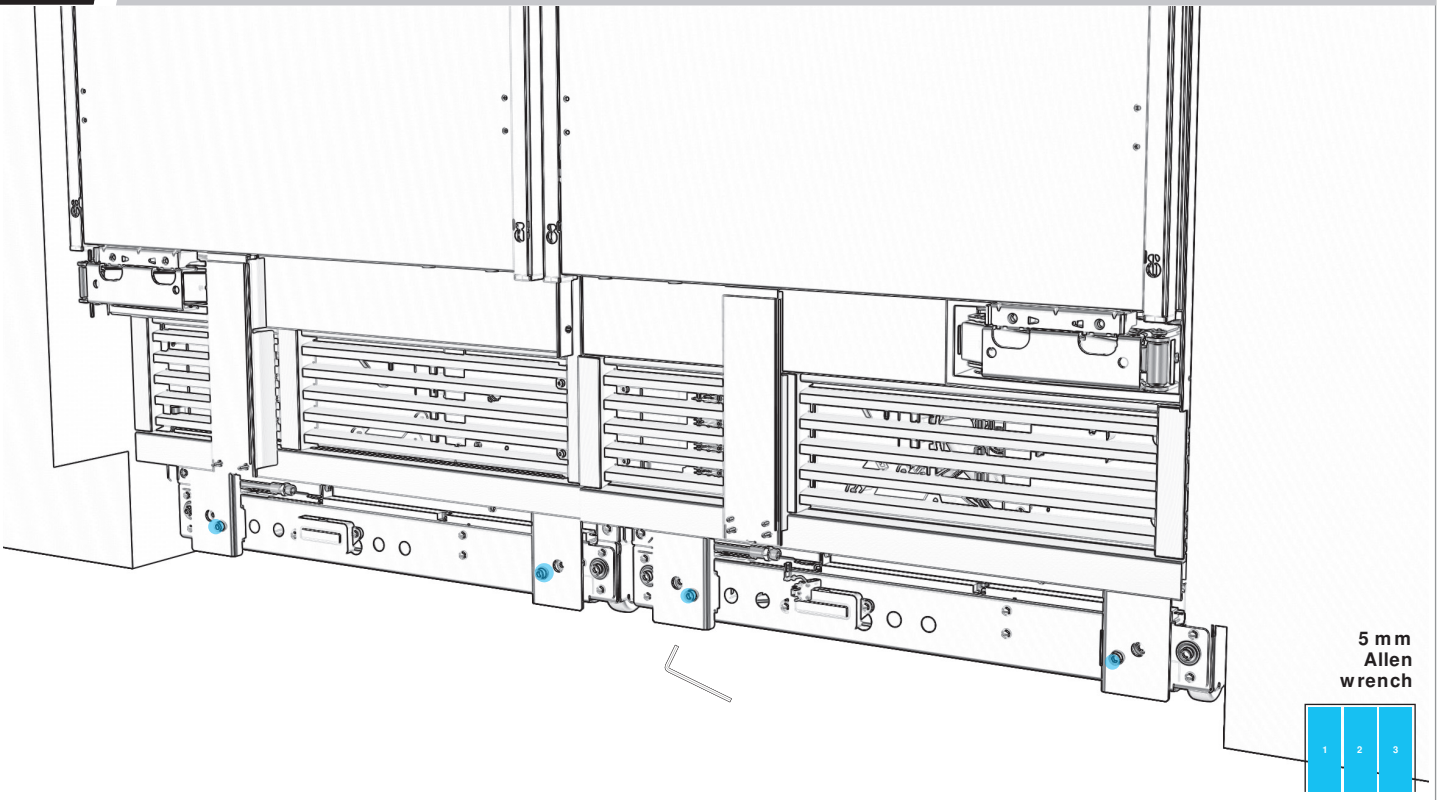

5 mm
Allen
wrench

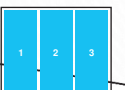

12.7

CONFIRM ALIGNMENT, READJUSTING IF NECESSARY.

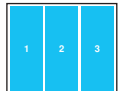
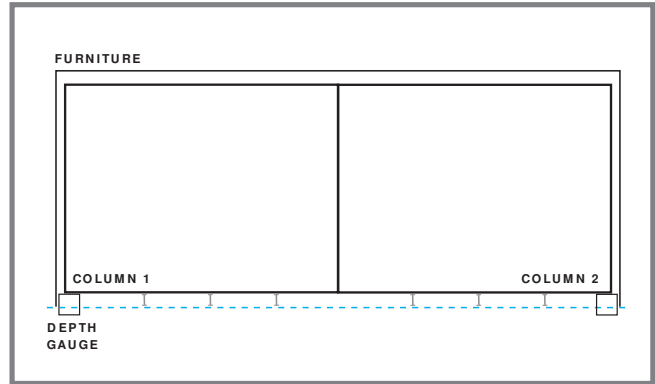
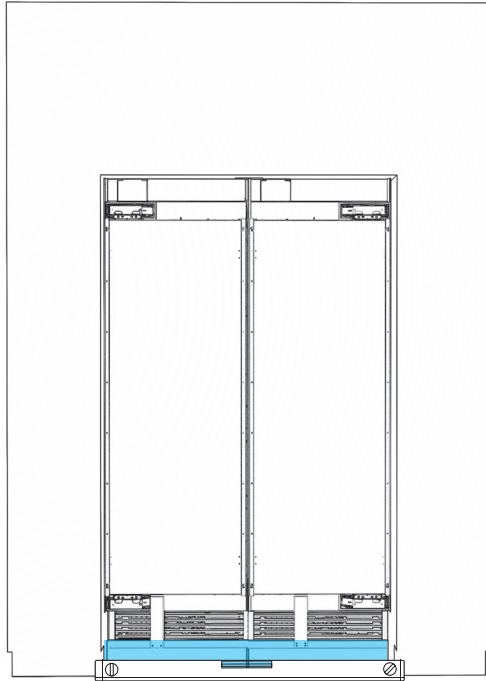

PANEI.

CUSTOM WOOD PREPARATION

13.1

PULL TAPE TO POP OFF BRACKET TRIM.

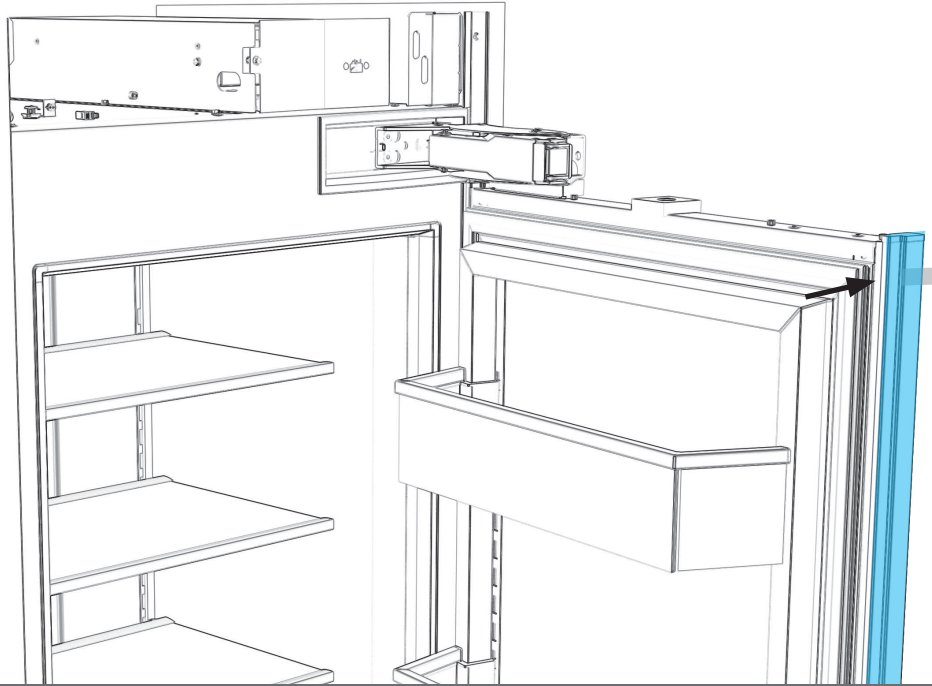

COMPLETE ALL STEPS FOR EACH UNIT.

13.2

PLACE PANEL FACE DOWN.

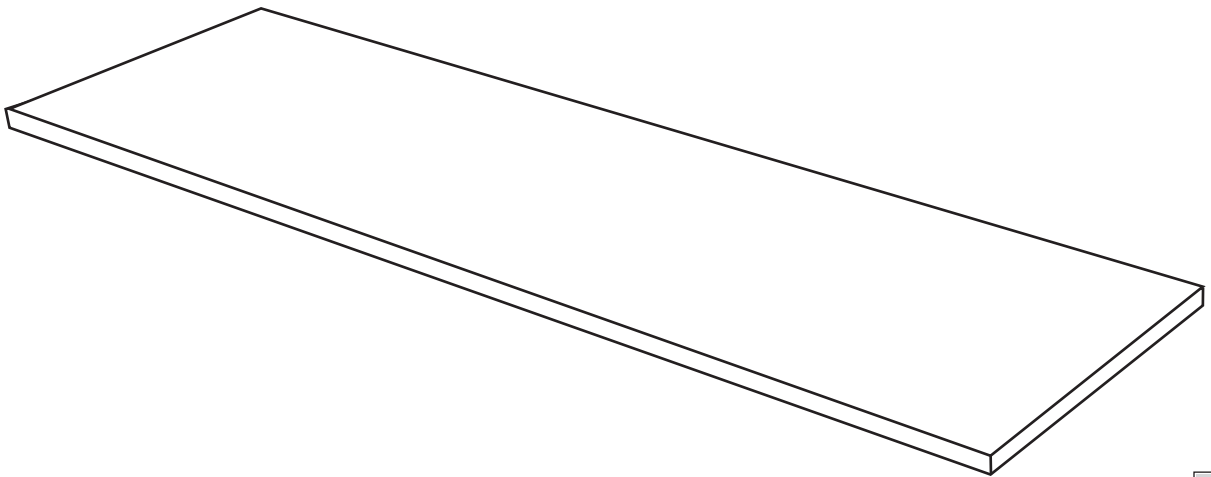

PLACE ON A FLAT, COVERED SURFACE.

13

PANEL: CUSTOM WOOD PREPARATION

13.3

MEASURE AND MARK CENTER OF PANEL.

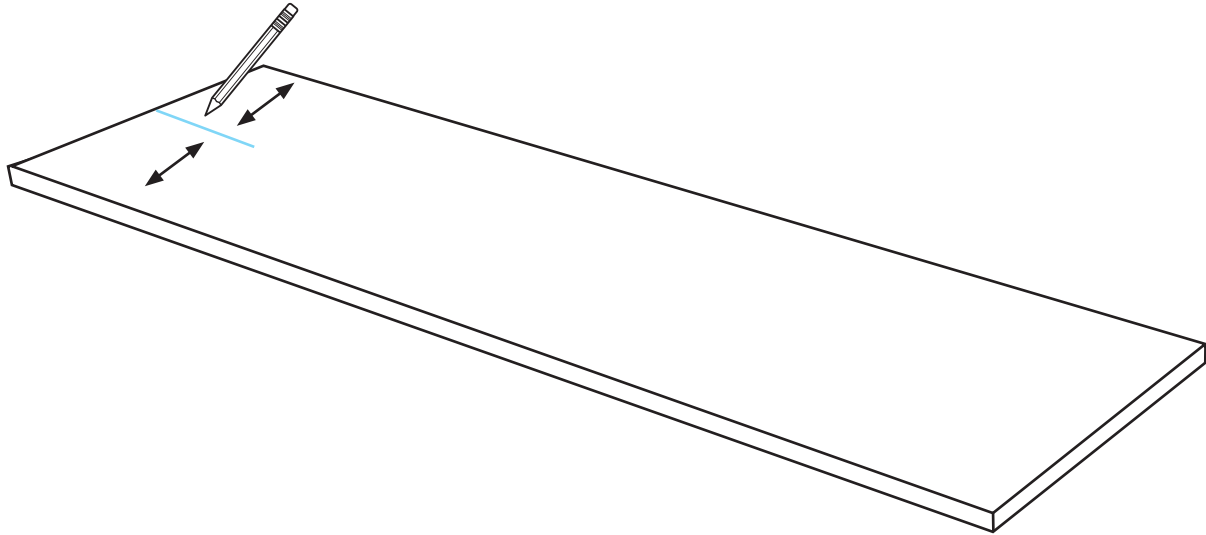

13.4

MARK LEFT AND RIGHT HOLES.

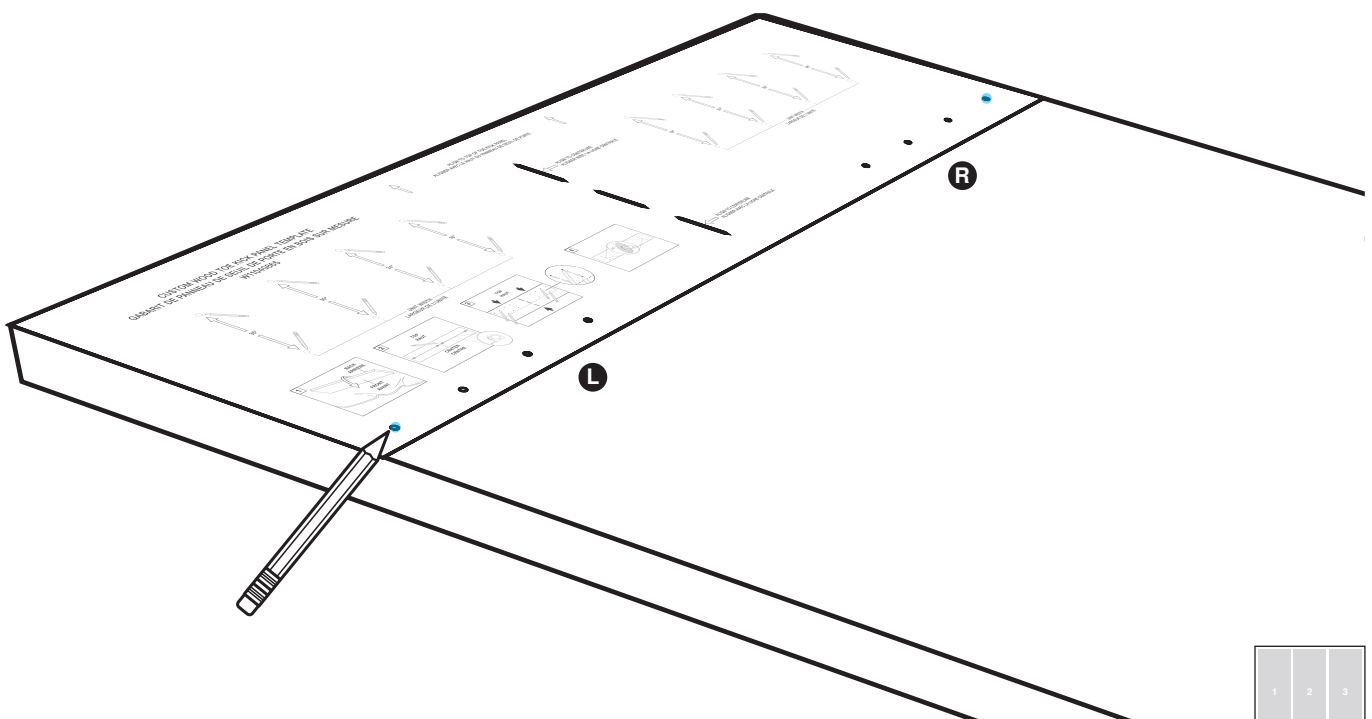

13.5

DRILL HOLES.

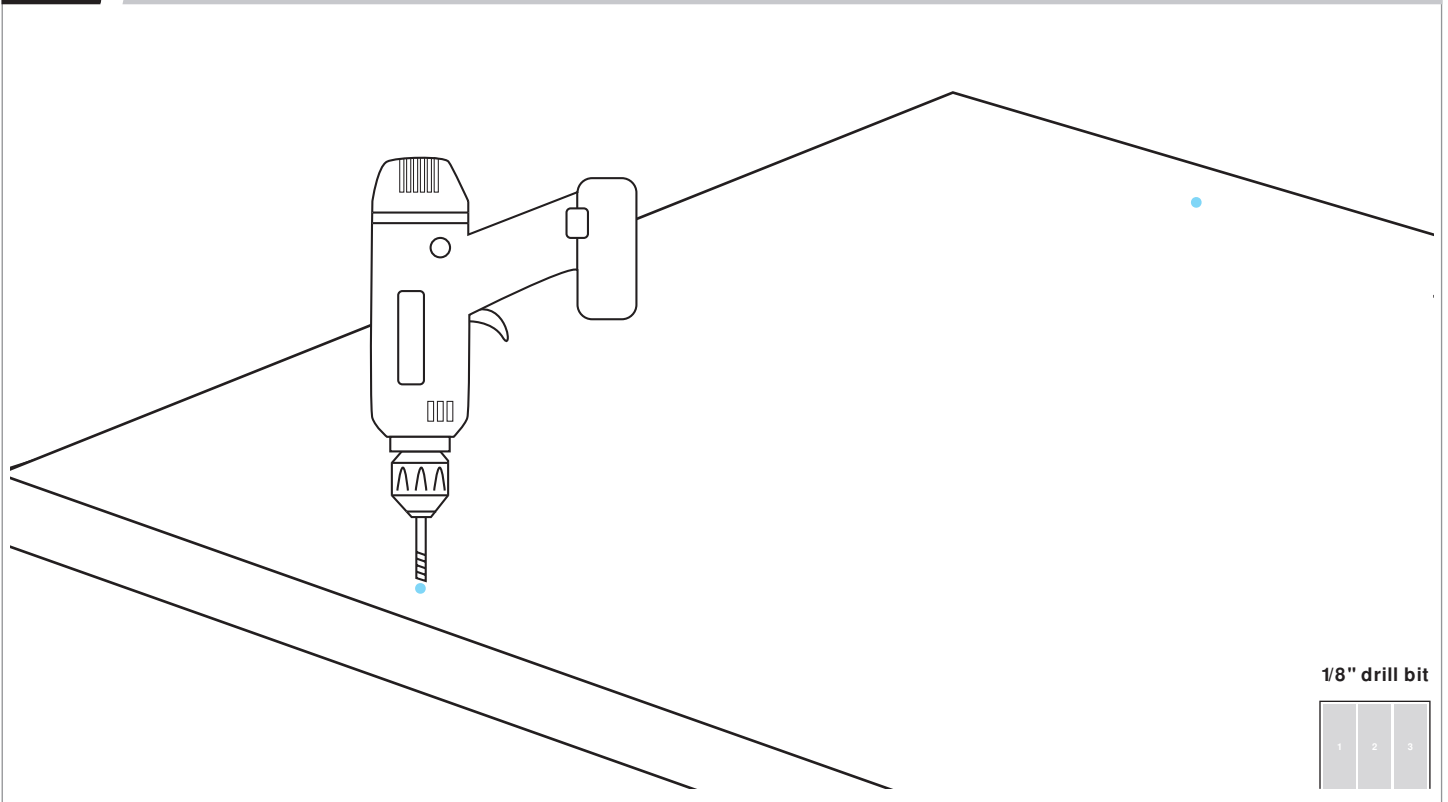

13.6

DRIVE FASTENERS INTO PRE DRILLED LOCATIONS.

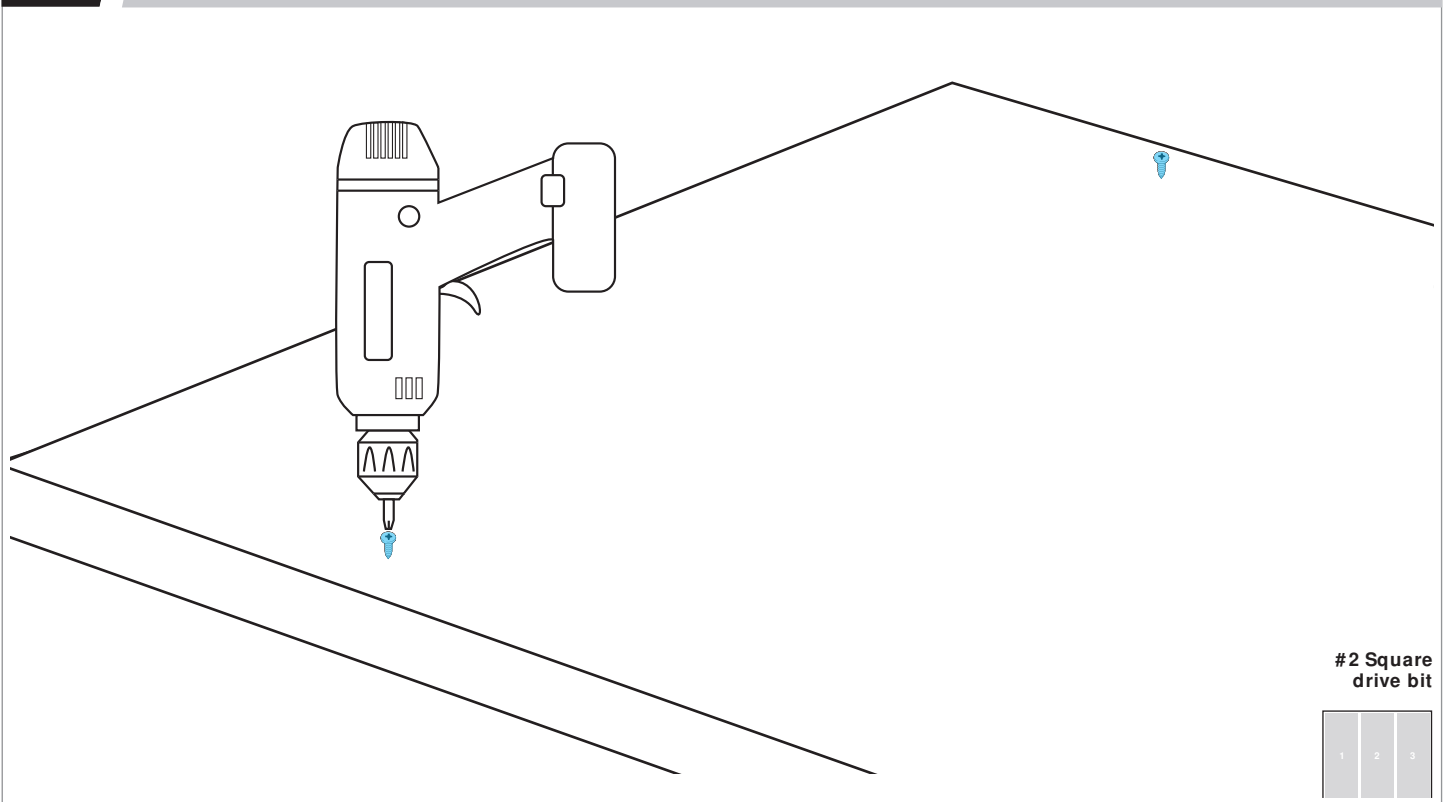

13

PANEL: CUSTOM
WOOD PREPARATION

13.7

ENSURE SPACE OF 1 8" 3.2 MM .

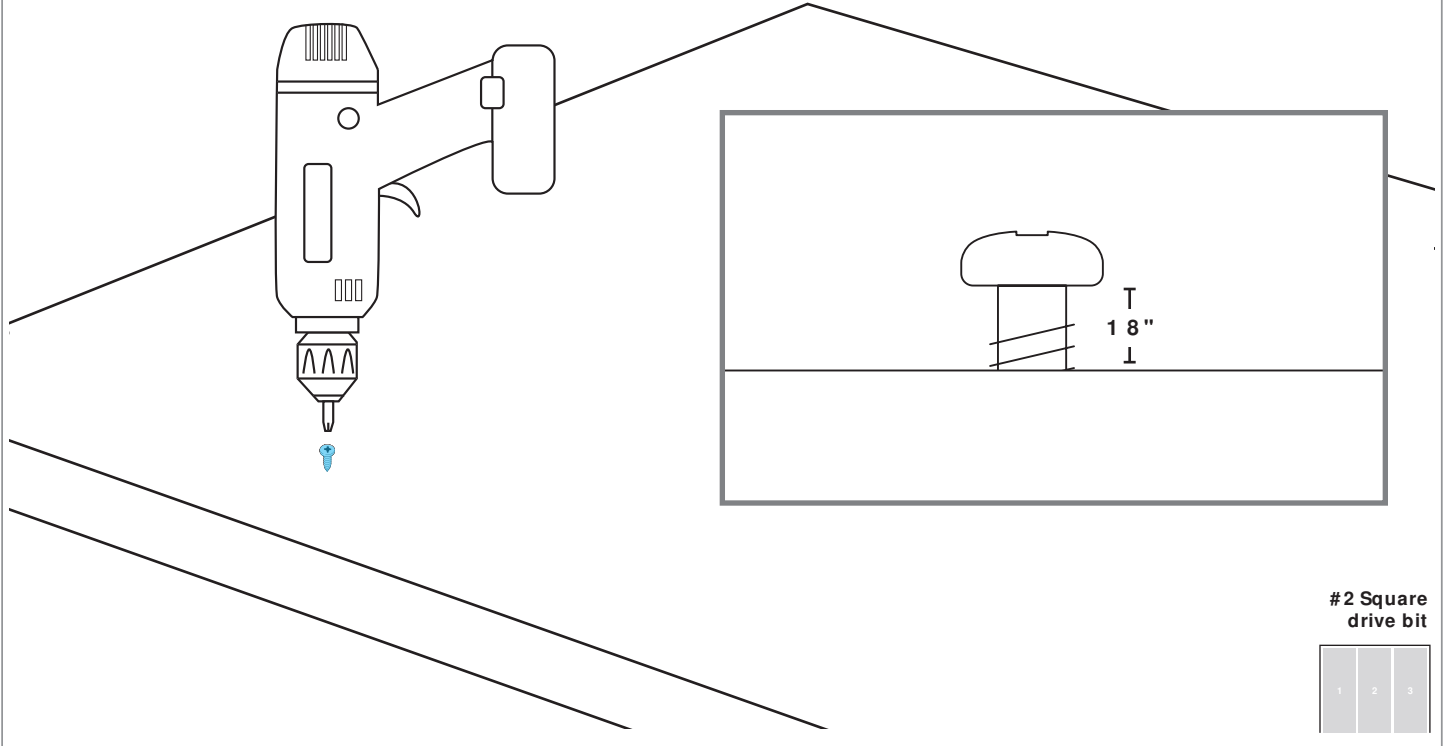

PANEI.

STAINLESS STEEL PREPARATION

14

PANEL: STAINLESS STEEL PREPARATION

14.1

PULL TAPE TO POP OFF BRACKET TRIM.

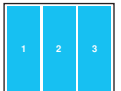
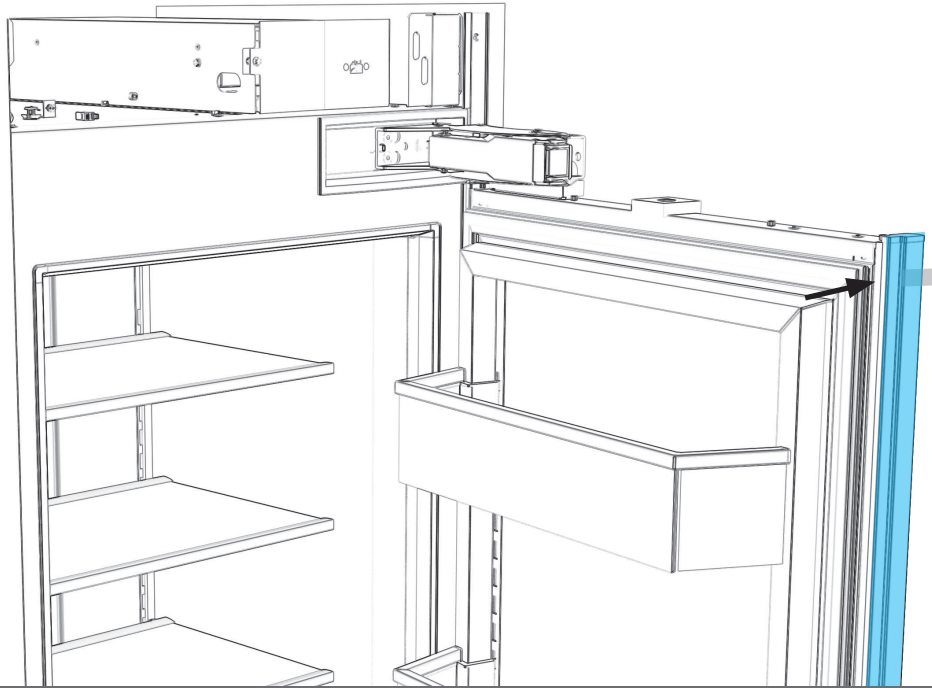

COMPLETE ALL STEPS FOR EACH UNIT.

14.2

PLACE PANEL FACE DOWN.

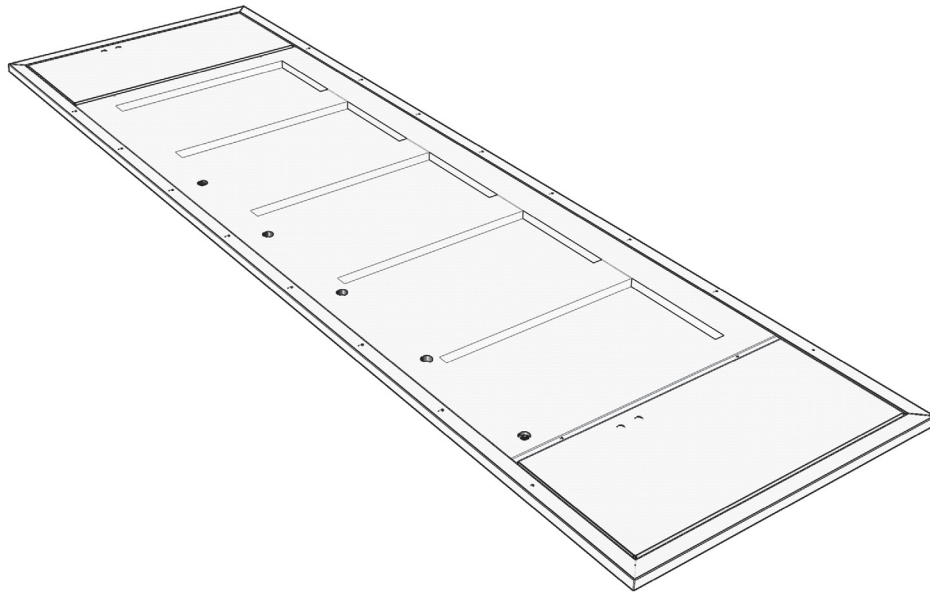

PLACE ON A FLAT, COVERED SURFACE

14.3 DRIVE FASTENERS INTO PRE DRILLED LOCATIONS.

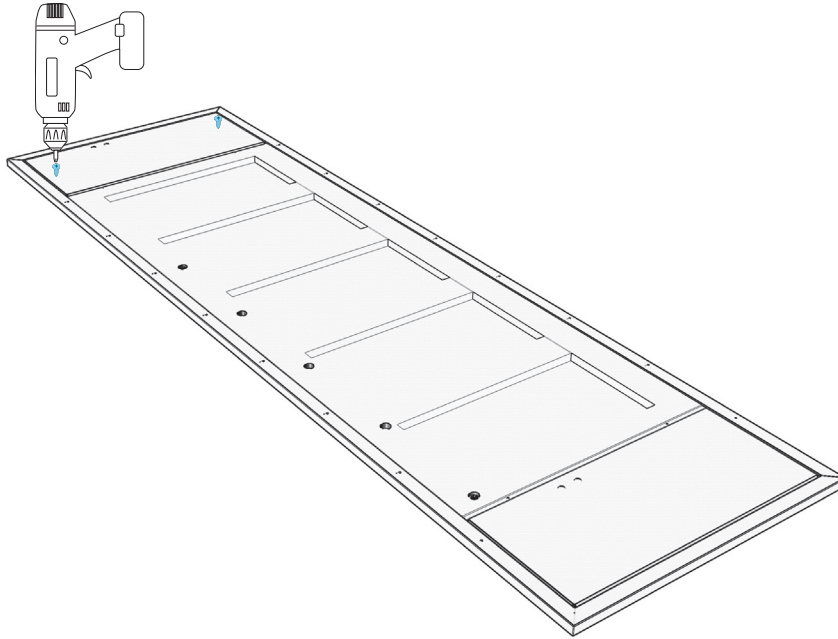

#2 Square
drive bit



14.4 ENSURE SPACE OF 18" 3.2 MM .

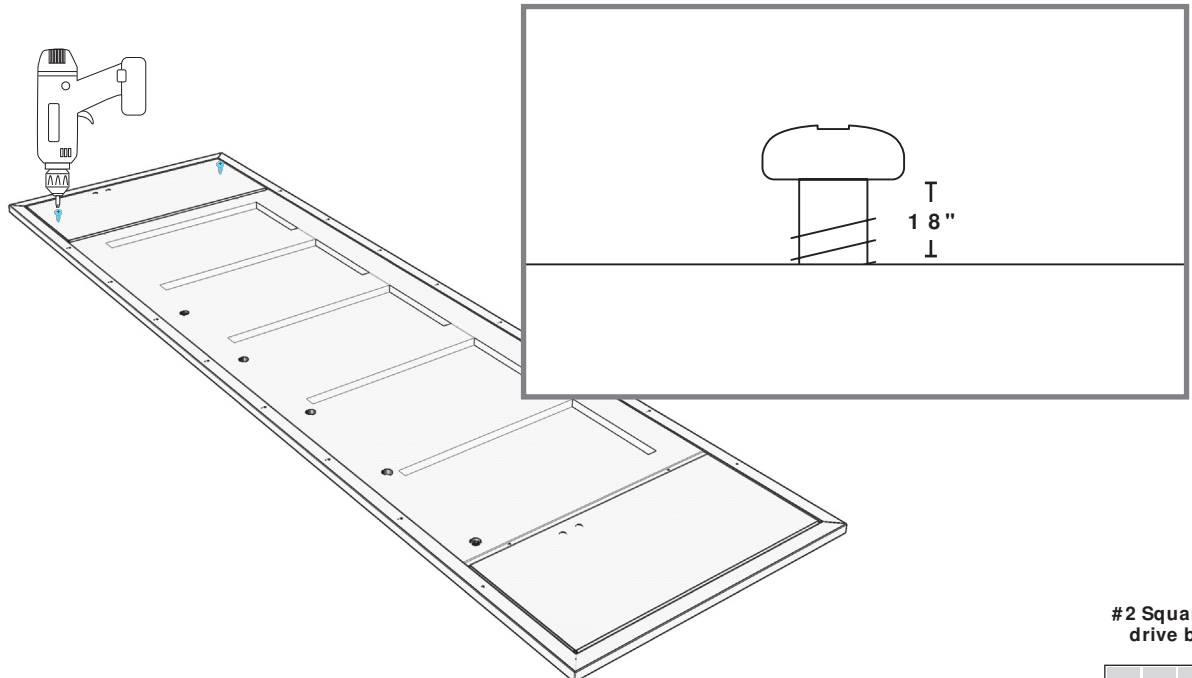

#2 Square
drive bit



PANEI.

HANG AND ALIGN

15.1

EACH COLUMN: INSERT FASTENERS INTO TOP SLOTS OF DOOR ADJUSTMENT TRIMS.

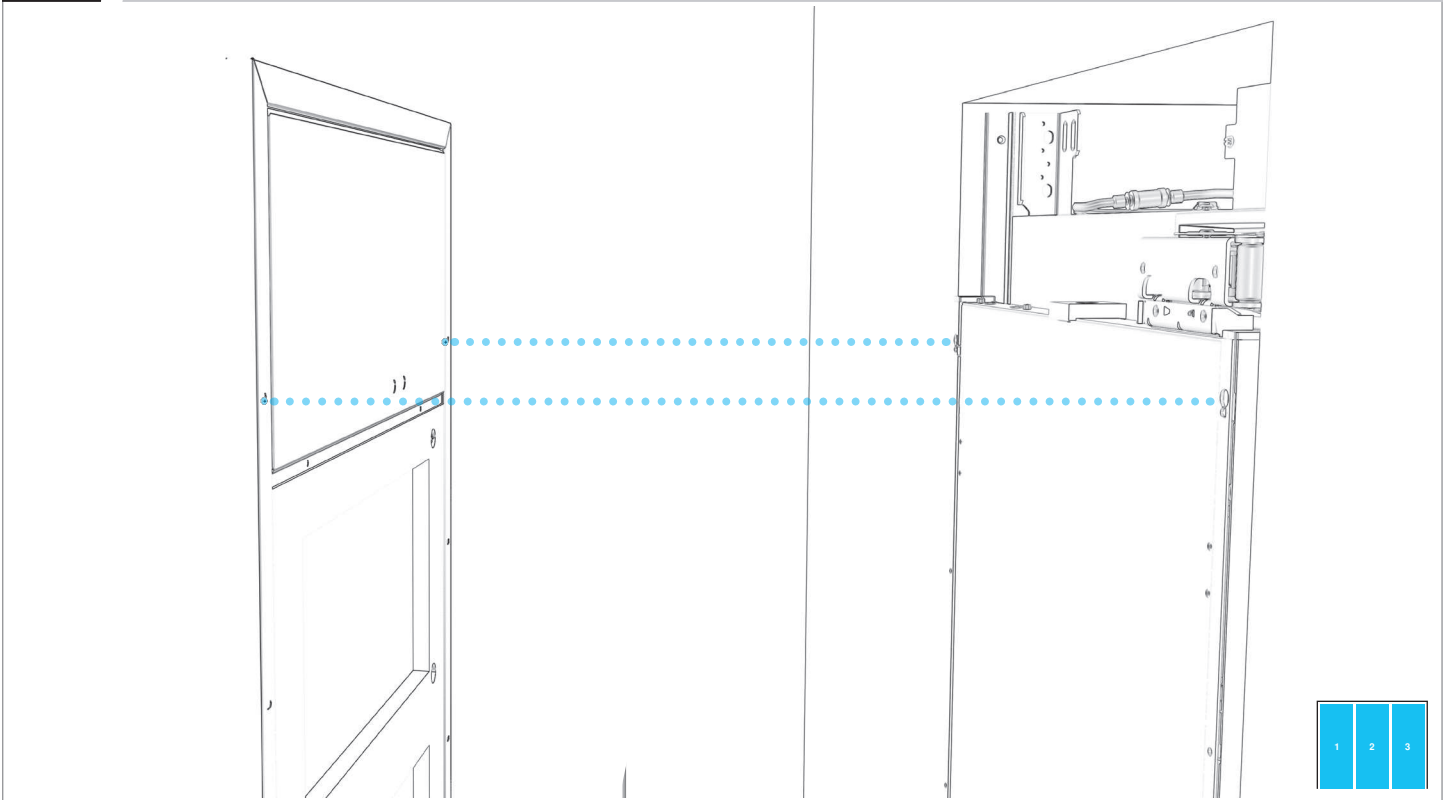

15.2

EACH COLUMN: MANUALLY ADJUST POSITION OF DOOR PANEL.

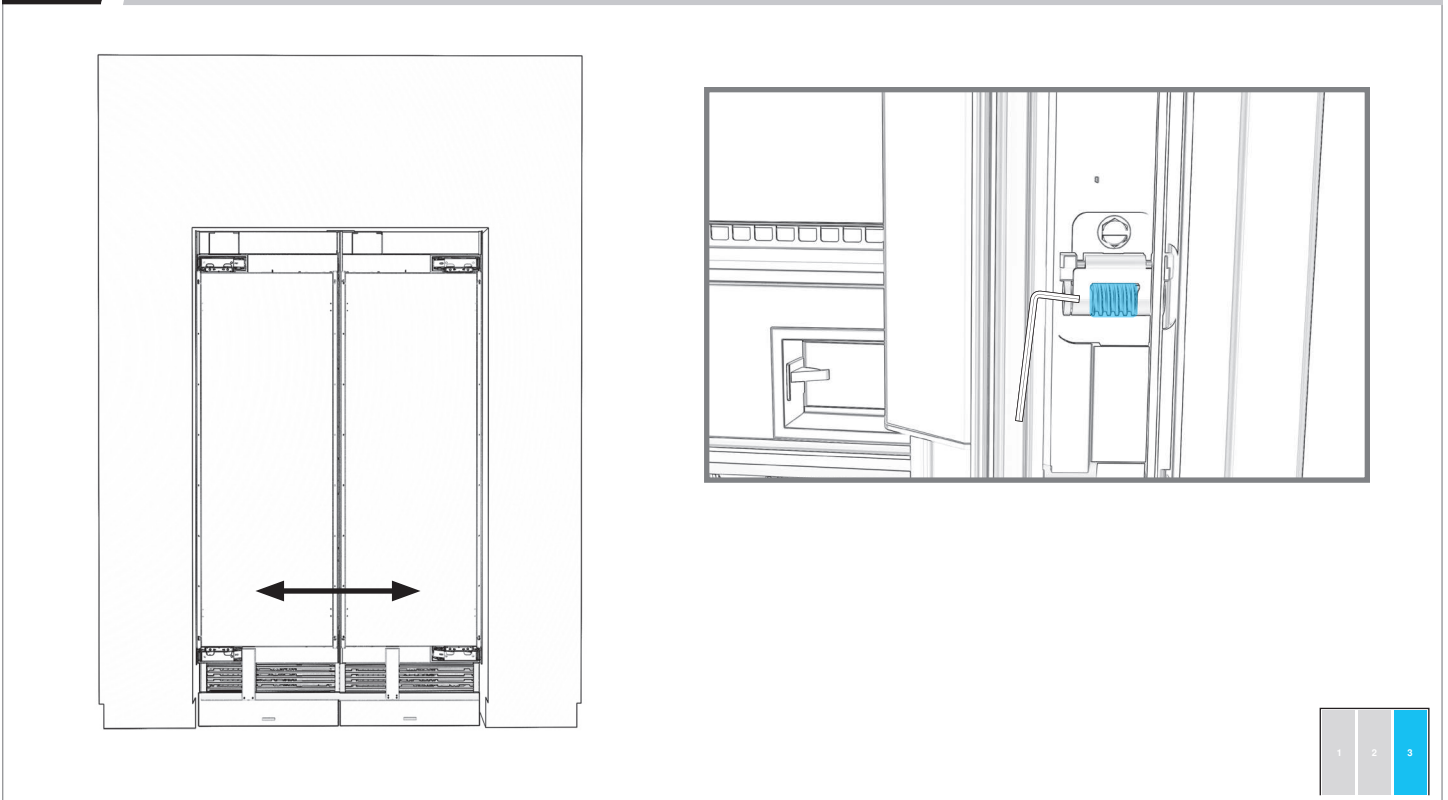

15.3

EACH COLUMN: TIGHTEN TOP TWO FASTENERS.

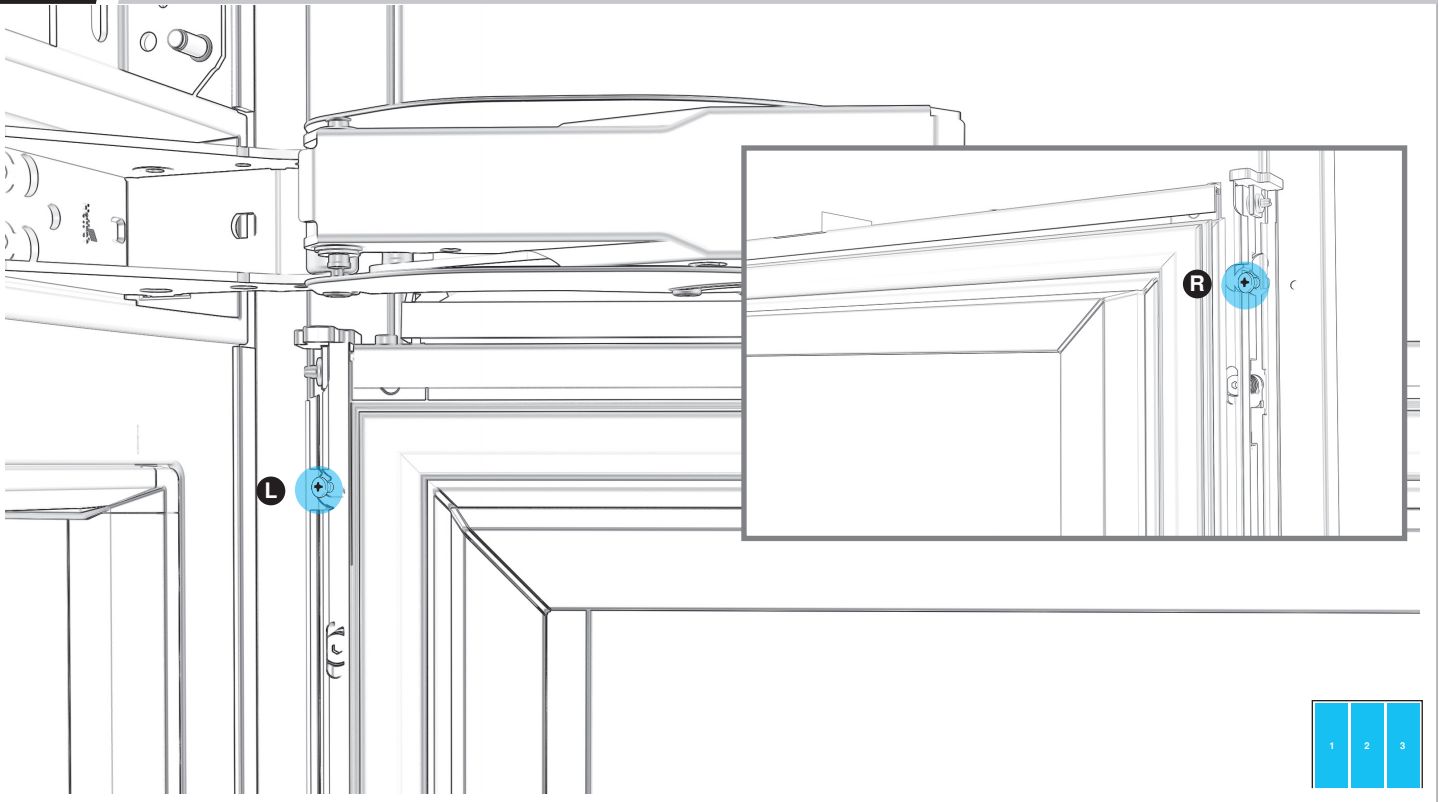

15.4

EACH COLUMN: LOOSELY DRIVE IN TWO BOTTOM FASTENERS.

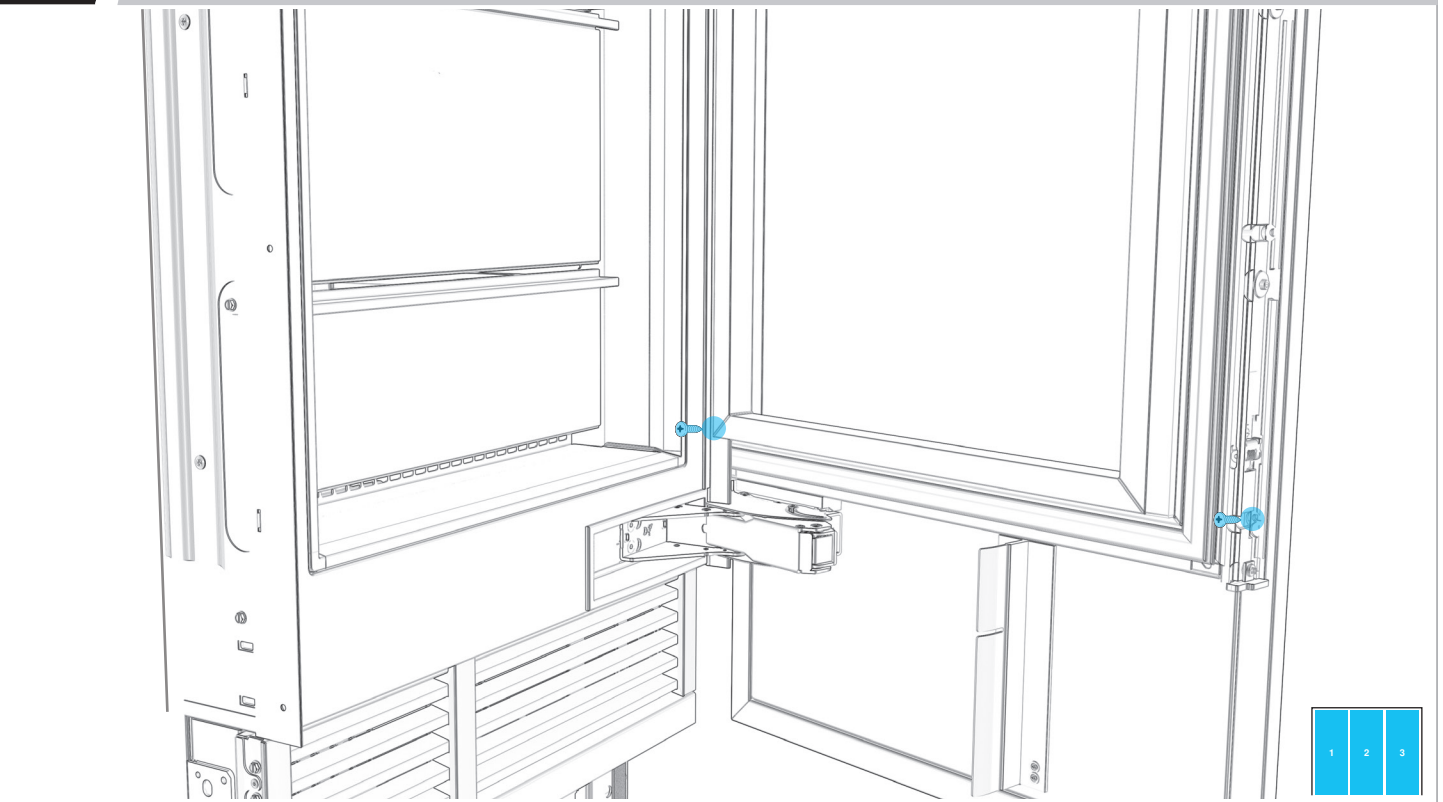

15.5

EACH COLUMN: LOOSEN THE SIX ADJUSTMENT SCREWS PER SIDE.

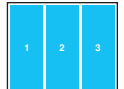
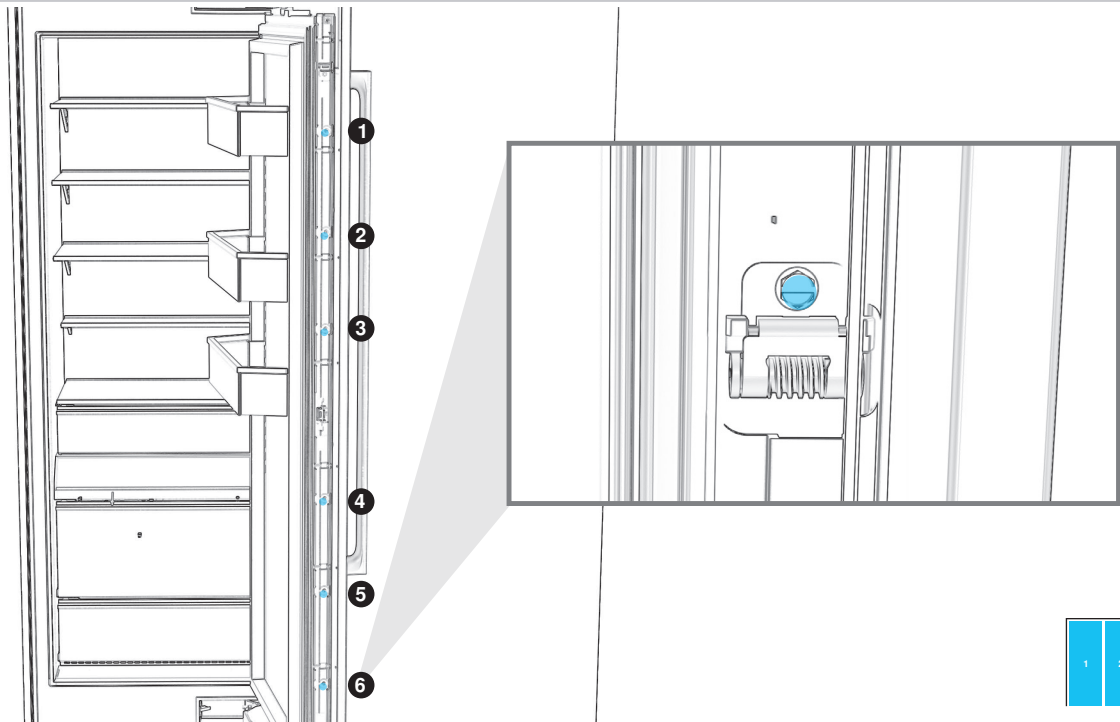

USE RIGHT ANGLE ADAPTER FOR GREATER EASE.

15.6

EACH COLUMN: ADJUST DOOR PANEL HEIGHT UP AND DOWN.

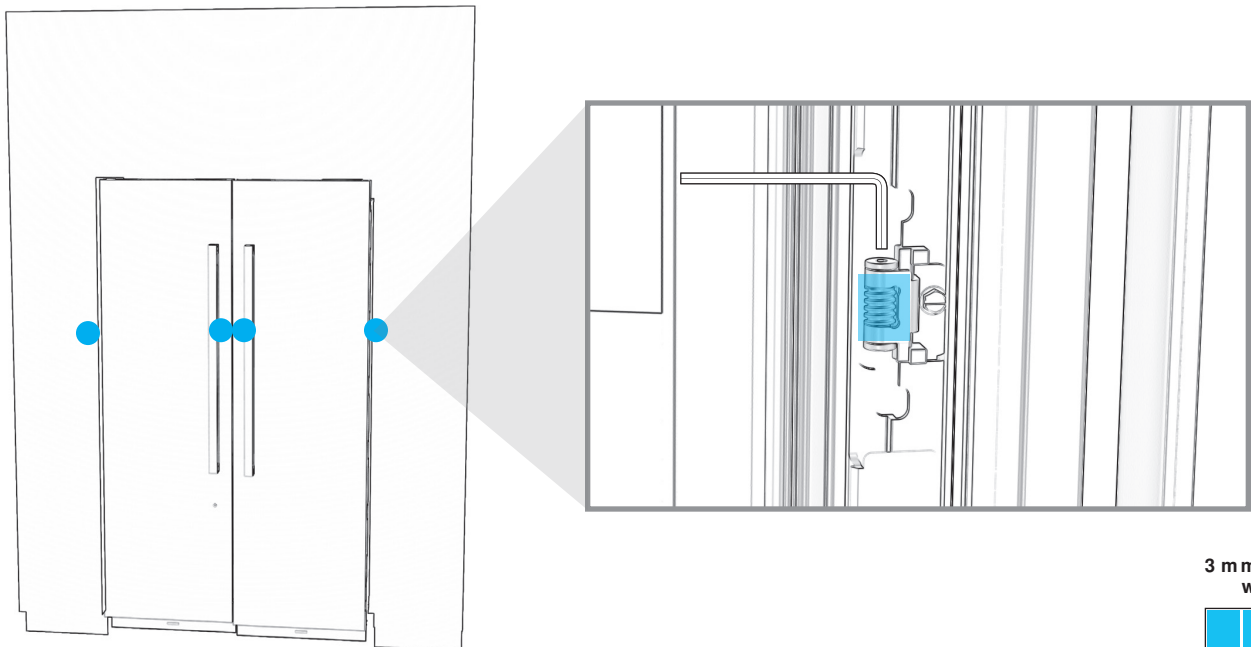

3 mm Allen
wrench

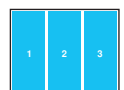

15

PANEL:
HANG AND ALIGN

15.7

EACH COLUMN: ADJUST DEPTH OF DOOR PANEL.

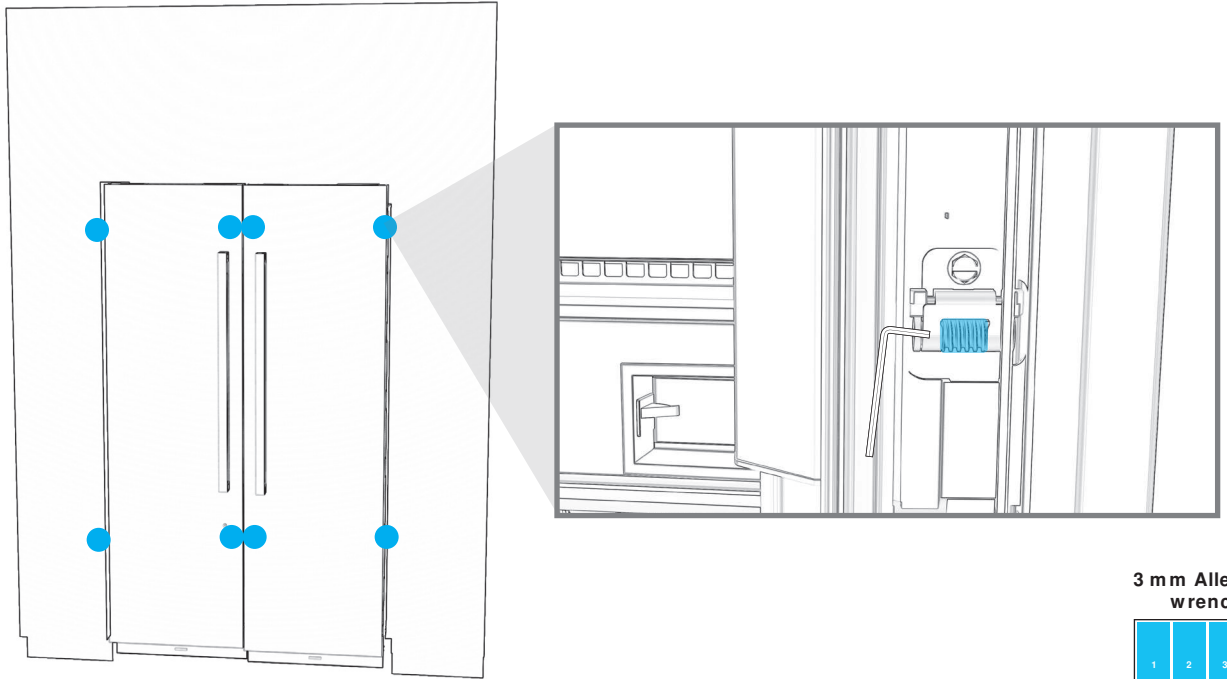

3 mm Allen
wrench

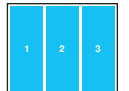

15.8

EACH COLUMN: CHECK THAT DOOR PANELS ARE IN PLANE WITH FURNITURE AND EACH OTHER.

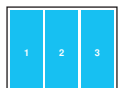
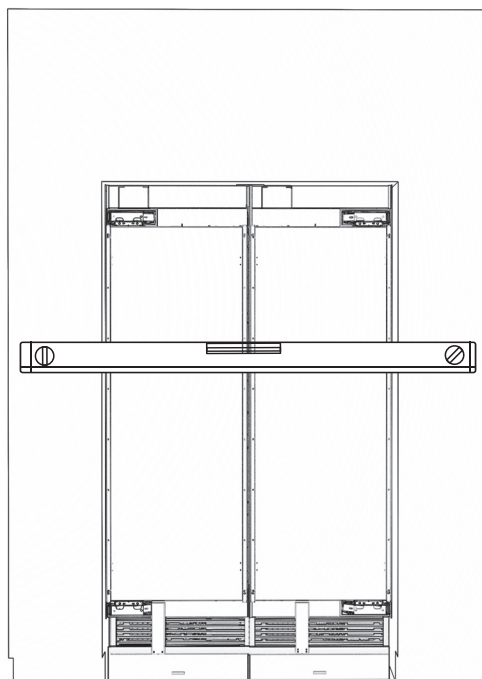

15.9

EACH COLUMN: INSERT AND TIGHTEN ALL 16 FASTENERS.

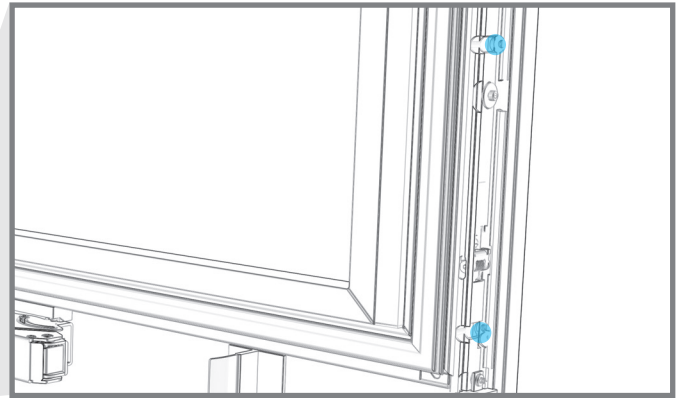
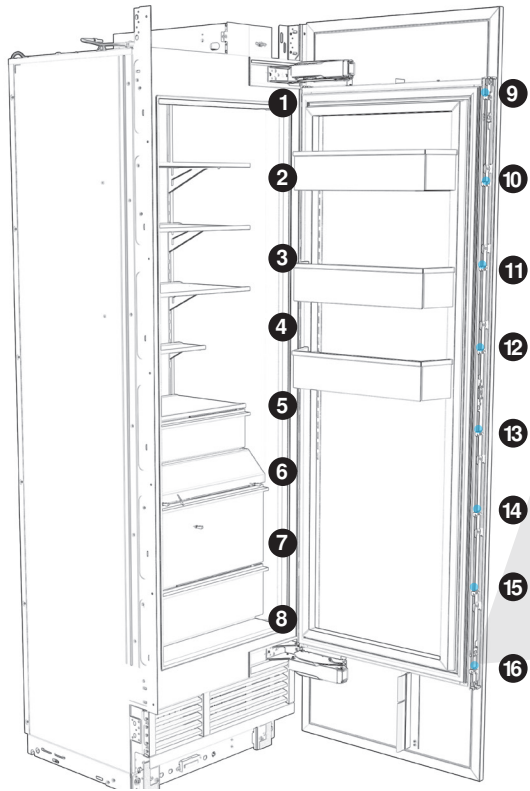

15.10

EACH COLUMN: TIGHTLY SECURE DOOR PANEL.

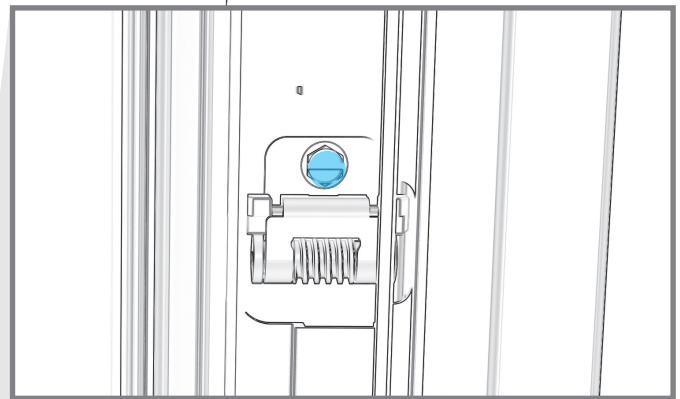
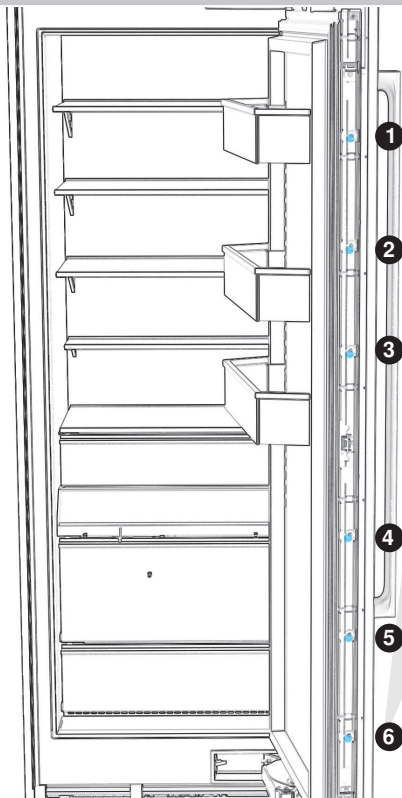

15

PANEL:
HANG AND ALIGN

15.11

EACH COLUMN: REINSTALL BRACKET TRIMS.

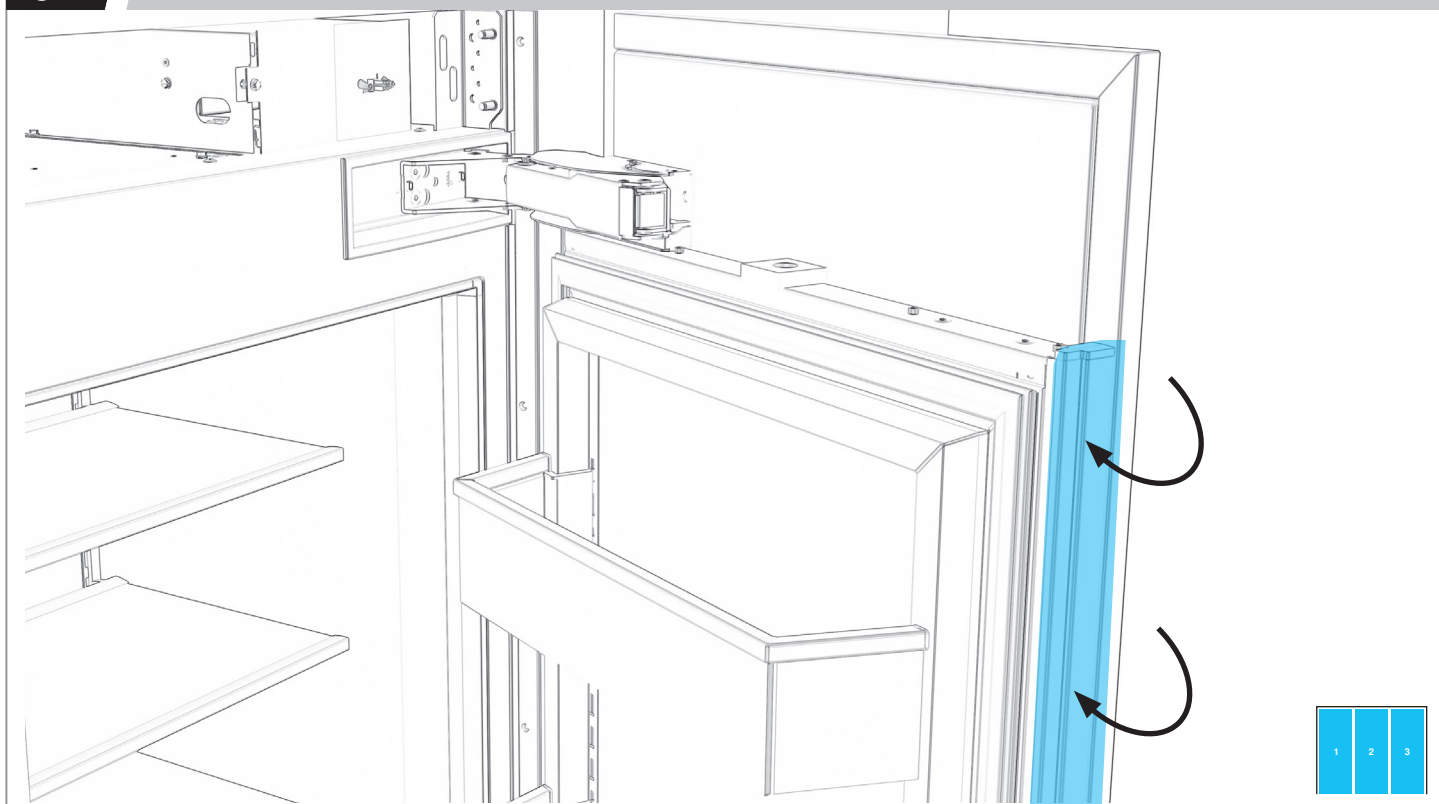

C O M P L E T E
16
INSTALLATION

16

COMPLETE INSTALLATION

16.1

EACH COLUMN: TIGHTEN SCREWS TO DRAW SIDE TRIM TIGHT ON EACH SIDE.

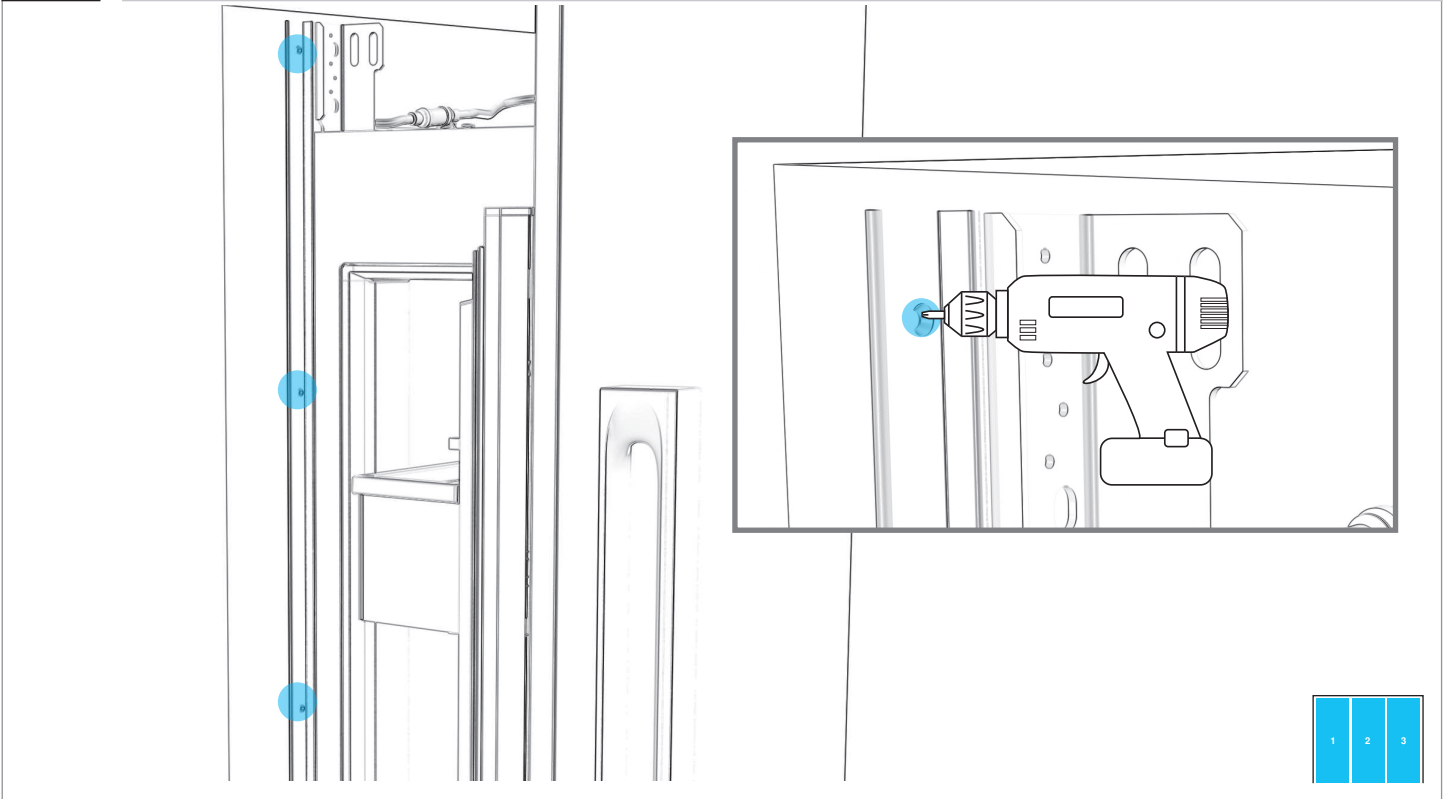

16.2

EACH COLUMN: SECURE AIR DIVIDERS TO DOOR PANELS.

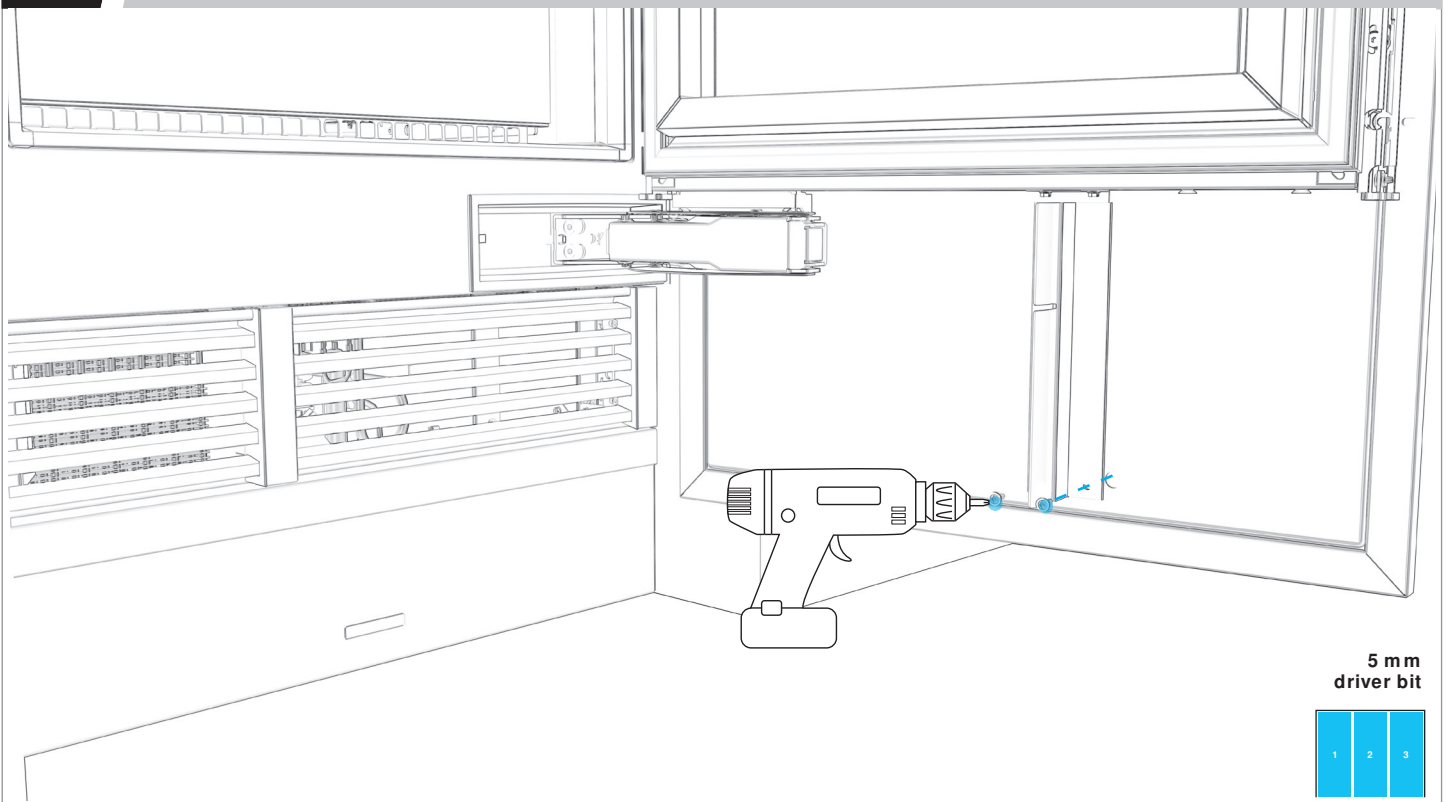

16.3

EACH COLUMN: REMOVE FILM.

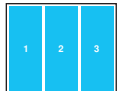
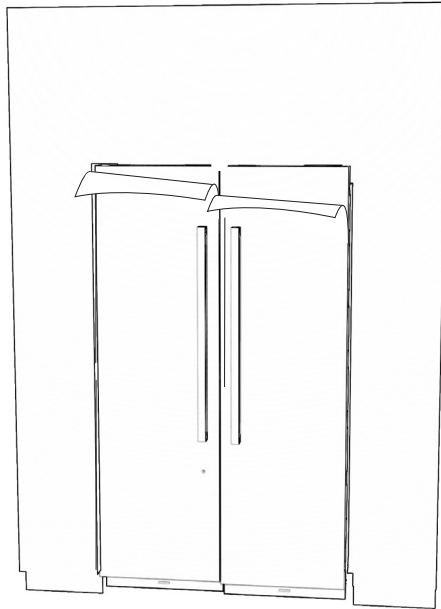

BEFORE FINAL CHECK, READ WARNING.

⚠ WARNING



Electrical Shock Hazard

Plug into a grounded 3 prong outlet.

Do not remove ground prong.

Do not use an adapter.

Do not use an extension cord.

**Failure to follow these instructions can result in death,
fire, or electrical shock.**

FINAL CHECK

- All packaging removed from the residence
- Columns plugged in, powered on and operating at peak performance
- Columns leveled
- Panels aligned and rechecked after 20 minutes operation
- Water supplies properly connected with no leaks
- Water filters installed (not applicable with reverse osmosis system)
- Water dispensers and/or ice makers working
- Any problems with installation or parts reported to JennAir Epicenter

OWNER WALKTHROUGH

If the owner is present, provide them with the User Guide. Guide the owner through:

- Control panel functions
- App and WiFi setup
- Discarding first few batches of ice
- Replacing the water filters
- Registering their columns
- How to contact JennAir Epicenter through jennair.com or at 1-800-JENNAIR (536-6247)

Votre sécurité et celle des autres est très importante.

Nous donnons de nombreux messages de sécurité importants dans ce manuel et sur votre appareil ménager. Assurez-vous de toujours lire tous les messages de sécurité et de vous y conformer.



Voici le symbole d'alerte de sécurité.

Ce symbole d'alerte de sécurité vous signale les dangers potentiels de décès et de blessures graves à vous et à d'autres.

Tous les messages de sécurité suivront le symbole d'alerte de sécurité et le mot "DANGER" ou "AVERTISSEMENT". Ces mots signifient :

⚠ DANGER

Risque possible de décès ou de blessure grave si vous ne suivez pas immédiatement les instructions.

⚠ AVERTISSEMENT

Risque possible de décès ou de blessure grave si vous ne suivez pas les instructions.

Tous les messages de sécurité vous diront quel est le danger potentiel et vous disent comment réduire le risque de blessure et ce qui peut se produire en cas de non-respect des instructions.

IMPORTANTES INSTRUCTIONS DE SÉCURITÉ

AVERTISSEMENT : Pour réduire le risque d'incendie, de choc électrique ou de blessure dans le cadre de l'utilisation du réfrigérateur, suivre les consignes de base suivantes :

- Pour éviter un danger provoqué par l'instabilité de l'appareil, ce dernier doit être fixé selon les instructions.
- Brancher l'appareil sur une prise à 3 alvéoles reliée à la terre.
- Installation ne devrait être effectuée que par le fabricant ou un agent autorisé.
- Ne pas enlever la prise de liaison à la terre.
- Ne pas utiliser d'adaptateur.
- Ne pas utiliser de rallonge.
- Déconnecter la source de courant électrique avant l'entretien.
- Replacer pièces et panneaux avant de faire la mise en marche.
- Enlever les portes de votre ancien réfrigérateur.
- Utiliser un produit de nettoyage ininflammable.
- Ne pas remiser ou utiliser de l'essence ou tout autre liquide ou vapeur inflammable à proximité de cet appareil ou de tout autre appareil électroménager. Les émanations peuvent causer des incendies ou explosions.
- Ne pas entreposer de substances explosives comme des aérosols avec agent propulseur inflammable dans ce réfrigérateur.
- Ne pas utiliser ou placer de dispositif électrique à l'intérieur des compartiments du réfrigérateur si ce dispositif ne correspond pas au type de dispositif expressément autorisé par le fabricant.
- Il faut l'aide d'au moins deux personnes pour déplacer et installer le réfrigérateur.
- Déconnecter la source de courant électrique avant d'installer la machine à glaçons (sur modèles avec ensemble de machine à glaçons prêt-à-installer uniquement).
- L'installation de la canalisation d'eau et de la machine à glaçons doit être effectuée par un technicien de service qualifié. Consulter les instructions d'installation fournies avec la trousse de machine à glaçons IC13B pour tous les détails.
- Raccorder à la canalisation d'arrivée d'eau potable uniquement.
- Utiliser un verre robuste pour prendre des glaçons (sur certains modèles).
- Cet appareil ne convient pas à une utilisation par des personnes (y compris des enfants) à capacités physiques, sensorielles ou mentales réduites, ou possédant un manque d'expérience et de connaissances, à moins qu'elles ne soient placées sous supervision ou qu'elles aient reçu des instructions concernant l'utilisation de l'appareil par une personne responsable de leur sécurité.
- Les enfants doivent être placés sous surveillance afin de s'assurer qu'ils ne jouent pas avec l'appareil.
- Pour éviter que les enfants ne soient coincés et ne suffoquent à l'intérieur du réfrigérateur, ne pas les laisser jouer ou se cacher à l'intérieur de l'appareil.
- Si le cordon d'alimentation est endommagé, il doit être remplacé par le fabricant, son agent de réparation ou toute autre personne qualifiée afin d'éviter tout danger.
- Ce réfrigérateur est destiné à un usage domestique et à d'autres usages similaires tels que :
 - espace de cuisine pour personnel de boutiques, bureaux et autres environnements professionnels;
 - résidences fermières et utilisation par les clients d'hôtels, de motels et d'autres types de résidences;
 - environnements de type chambres d'hôtes;
 - Banquets et autres utilisations non commerciales semblables.

CONSERVEZ CES INSTRUCTIONS

! AVERTISSEMENT

Risque de suffoquer

Enlever les portes de votre vieux réfrigérateur.

Le non-respect de cette instruction peut causer un décès ou des lésions cérébrales.

Renseignements importants à propos de la mise au rebut des fluides réfrigérants :

Mettre le réfrigérateur au rebut conformément à la réglementation fédérale et locale. Les fluides réfrigérants doivent être évacués par un technicien certifié et agréé par l'EPA conformément aux procédures établies.

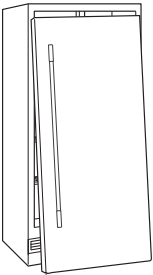

IMPORTANT : Le risque qu'un enfant puisse se retrouver coincé et suffoquer n'est pas chose du passé. Les réfrigérateurs jetés ou abandonnés restent dangereux, même s'ils ne restent à l'extérieur que pour "quelques jours seulement". Si l'ancien réfrigérateur doit être mis au rebut, suivre les instructions suivantes afin d'éviter les accidents.

Avant de jeter l'ancien réfrigérateur ou congélateur :

- Enlever les portes.
- Laisser les tablettes en place de sorte que les enfants ne puissent pas y pénétrer facilement.

FACILE . RAPIDE . SÛR .

Grâce au tout premier réfrigérateur intégré en colonne JennAir®, nous avons complètement repensé le processus d'installation pour éliminer les problèmes que rencontre notre concurrence de moins bonne qualité. Certaines des caractéristiques les plus attendues des installateurs professionnels :

- **Panneau à six points ajustables dissimulés**
Alignement facile et précis
- **Devant en métal**
Durabilité améliorée
- **Système de cales Rotter et bride Badass à ajuster sur place**
Guide et maintien l'appareil en place
- **Panneaux en acier inoxydable avec centre en bois franc**
faciles à préparer et à suspendre, aucun perçage dans le métal nécessaire
- **Ajustement avant de l'aplomb précis à 4 points**
Sur des roulettes robustes qui supportent facilement tout le poids
- **Zone pour appareil de plus grande taille**
Réduit les modifications nécessaires pour remplace un appareil encastré ou l'appareil de la concurrence

Et grâce à votre aide, nous ne pourrions que nous améliorer.

Communiquer avec JennAir Epicenter à partir de jennair.com ou composer le **1800 JENNAIR (536-6247)** pour partager des conseils et astuces d'installation ou parler avec un expert de l'installation qui connaît le processus par cœur.

POURQUOI AIMONS NOUS LES INSTALLATEURS JENNAIR ?

CE SONT DE VRAIS PROFESSIONNELS ET PERFECTIONNISTES .

Ils sont en mesure d'effectuer une installation parfaite, ajustée au millimètre près. Une installation sans faille est primordiale pour le fonctionnement, l'apparence et permettre de profiter du produit pendant toute sa durée de vie utile. Nos installateurs réalisent cet exploit tous les jours.

ILS FONT LEUR TRAVAIL, ET NOUS AIDENT À FAIRE LE NÔTRE.

Ces experts connaissent les produits JennAir® comme le fond de leur poche. Ils se forment de façon intensive à l'installation JennAir pour connaître les plus récentes techniques et les conseils des autres installateurs et ainsi installer ces appareils de pointe avec la plus grande facilité. Leurs commentaires sont très importants pour nous puisqu'ils permettent d'améliorer et de perfectionner nos installations.

ILS PENSENT À TOUS LES DÉTAILS DE L'EXPÉRIENCE.

Un dévouement sans compter est à la base de tout. L'expérience Jennair commence dès l'instant où un installateur apporte l'appareil chez un client. Garder le lieu d'installation propre, prendre un très grand soin des appareils et de la maison, et offrir une introduction inoubliable de l'appareil font tous partie du plan de match.

TABLE DES MATIÈRES

INTRODUCTION

117	INSTRUCTIONS SUR LA SÉCURITÉ
121	OUTILS ET PIÈCES
123	TROUSSES DE JOINT
126	CONFIGURATIONS
128	DIMENSIONS DU PRODUIT
130	STYLE DE PORTE
131	DIMENSIONS DE L'OUVERTURE
136	PRÉPARATION DU SITE
139	INSTRUCTIONS IMPORTANTES

PRÉPARATION

140	SECTION 1	PRÉPARATION DE L'APPAREIL
147	SECTION 2	PRÉPARATION DE LA TROUSSE DE JOINT
152	SECTION 3	PRÉPARATION DE LA BRIDE DE POSITIONNEMENT
155	SECTION 4	INSTALLATION DE LA BRIDE BADASS
164	SECTION 5	PRÉPARATION DU MEUBLE

INSTRUCTIONS

170	SECTION 6	INSTALLATION DU PREMIER APPAREIL
180	SECTION 7	INSTALLATION DU DEUXIÈME APPAREIL
188	SECTION 8	INSTALLATION DU TROISIÈME APPAREIL
196	SECTION 9	PRÉPARATION DE L'APPAREIL POUR SON UTILISATION

ACCESSOIRES

202	SECTION 10	PRÉPARATION DE LA PLINTHE EN BOIS PERSONNALISÉE
205	SECTION 11	PRÉPARATION DE LA PLINTHE EN ACIER INOXYDABLE
208	SECTION 12	ALIGNEMENT ET INSTALLATION DE LA PLINTHE
213	SECTION 13	PRÉPARATION DU PANNEAU EN BOIS PERSONNALISÉ
218	SECTION 14	PRÉPARATION DU PANNEAU EN ACIER INOXYDABLE
221	SECTION 15	SUSPENSION ET ALIGNEMENT DU PANNEAU

TERMINER

227	SECTION 16	TERMINER L'INSTALLATION
230		VÉRIFICATION FINALE

OUTILS ET PIÈCES FOURNIS

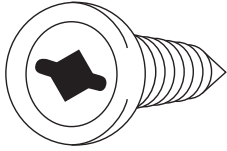

Vis à tête carrée no 2
(3-24004-079)

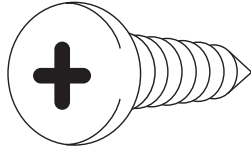

Vis à tête cruciforme
8-18 x 3/4
(W 11041176)

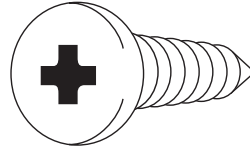

Vis 6-20 x 0,375
(246131)

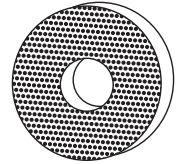

Tampons de maintien
(W 10840464)

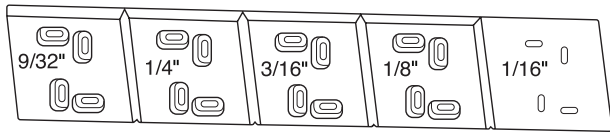

Cinq cales d'installation
(W 10913387)

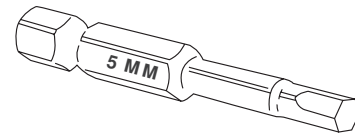

Embout de perceuse de 5 mm
(W 11121505)

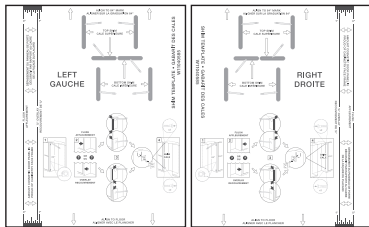

Gabarit d'installation des cales
(W 11040585)

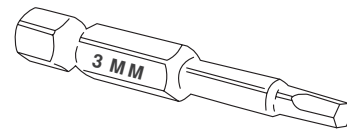

Embout de perceuse de 3 mm
(W 11121512)

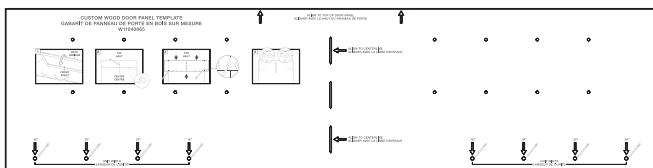

Gabarit d'installation de plinthe et de panneau de porte
(W 11040865)

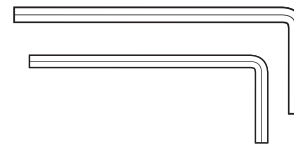

†Clé Allen® de 3 mm
Clé Allen® de 5 mm



**LIRE ET OBSERVER LES INSTRUCTIONS D'INSTALLATION FOURNIES
AVEC CHACUN DES OUTILS MENTIONNÉS DANS LA LISTE.**

OUTILS ET PIÈCES

NON FOURNIS

OUTILS

- Perceuse sans fil et em bouts de perceuse ou perceuse à percussion
- Trousse d'em bouts de perceuse incluant des em bouts de 3/32 po et 1/8 po
- Deux clés à molette
- Embout cruciforme no 2
- Tourne-écrou magnétique de 1/4 po
- Embout de perceuse carré no 2
- Niveau ou règle de précision d'au moins 48 po (peut remplacer une pièce de garniture d'usine une fois enlevée.)
- Clés à fourche de 3/8 po et 1/2 po
- Ruban à mesurer
- Couteau utilitaire
- Ruban adhésif de masquage
- Chariot pour appareil ménager
- Adaptateur de perceuse à angle droit
- Rallonge pour perceuse de 6 po
- Vis à bois à tête cylindrique n° 8 de différentes longueurs dont : 1po, 1 1/4 po et 1 1/2 po

PIÈCES

- Tuyau d'alimentation en eau flexible approuvé par les codes en vigueur
- Panneaux de porte décoratifs personnalisés
 - Panneaux en acier inoxydable : à commander de JennAir
 - Panneaux de bois personnalisés : demander à un fabricant de meubles ou menuisier qualifié
- Des attaches supplémentaires seront requises en fonction de la fabrication des meubles

POUR QUOI UTILISER LE SYSTÈME DE CALES ROTTER ET LA BRIDE BADASS?

Cette procédure recommandée pourra sembler étrange pour un installateur, mais elle ajoute beaucoup de valeur au client et à vous.

Utiliser le système Rotter pour :

- Aider à positionner l'appareil sans rayer aucune surface
- Créer un espace précis de 1/8 po de chaque côté
- Toujours avoir des cales prêtes et personnalisées pour chaque site
- Garder l'appareil stable dans l'ouverture pendant toute sa durée de vie
- Éliminer les problèmes de mauvais alignement chez le client

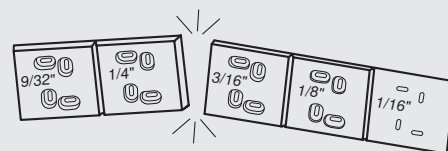

TROUSSES DE JOINT

VENDUES SÉPARÉMENT

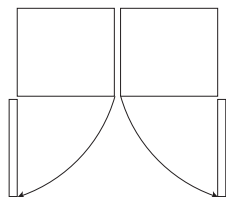

Trousse de joint poignée à poignée
(JAJ13HSS)

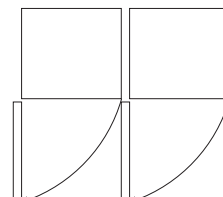

Trousse de joint poignée à charnière
(JAJ11HSS)

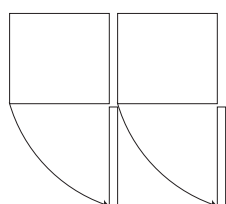

Trousse de joint charnière à poignée
(JAJ12HSS)

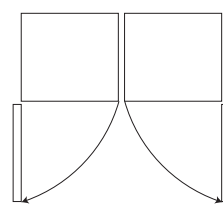

Trousse de joint poignée à poignée Burlesque
(JAJ14JSS)

OUTILS ET PIÈCES INCLUS DANS LES ENSEMBLES DE JOINT

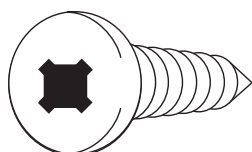

Vis 10-13 x 2,0 chrome

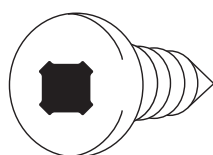

Vis 10-13 x PN chrome
(W 11117666)

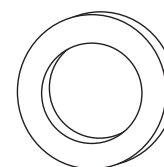

17 rondelles plates
(8534057)

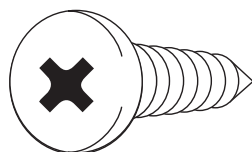

Vis 8-18 x MFI 6L HL SS noir
(W 11117377)

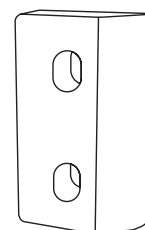

Espaceur de la trousse de joint
(W 1111782)



LIRE ET OBSERVER LES INSTRUCTIONS D'INSTALLATION FOURNIES
AVEC CHACUN DES OUTILS MENTIONNÉS DANS LA LISTE.

TROUSSES DE JOINT

VENDUES SÉPARÉMENT

OUTILS ET PIÈCES INCLUS DANS LES ENSEMBLES DE JOINT SUITE

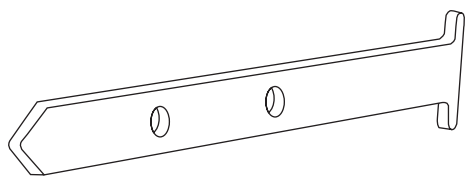

Support de bride de positionnement
(W 11111772)

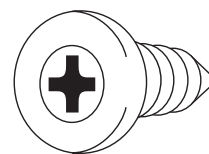

(14) vis 8-15 x "L" métrique chrome
(828 1252)

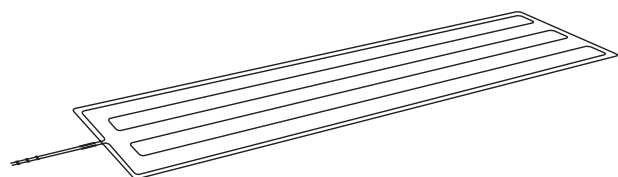

Tapis chauffant à pellicule autocollante
(W 10912090)

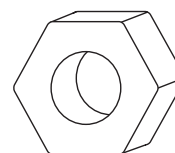

(8) écrous hexagonaux M6-1 x 6 10 mm métriques
(W 10854505)

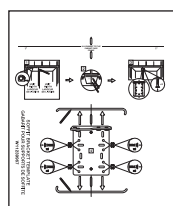

Gabarit d'installation de support pour soffite
(W 11040584)

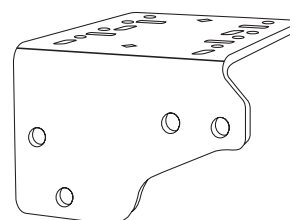

Bride de soffite **Badass**
(W 11111754)

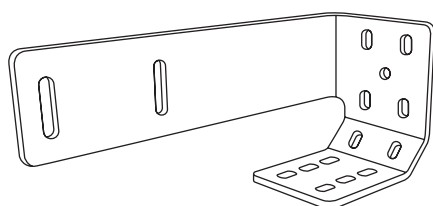

Bride de positionnement
(W 11111771)



LIRE ET OBSERVER LES INSTRUCTIONS D'INSTALLATION FOURNIES
AVEC CHACUN DES OUTILS MENTIONNÉS DANS LA LISTE.

TROUSSES DE JOINT

VENDUES SÉPARÉMENT

OUTILS ET PIÈCES INCLUS DANS LES ENSEMBLES DE JOINT SUITE

Trousse de joint poignée à poignée

Garniture (poignée) gauche
(W 11103734)

Garniture (poignée) droite
(W 11103737)

Trousse de joint poignée à charnière

Garniture (poignée) gauche
(W 11103734)

Garniture (charnière) droite
(W 11103736)

Trousse de joint poignée à charnière

Garniture (poignée) gauche
(W 11103737)

Garniture (charnière) droite
(W 11103735)

CONFIGURATIONS

2 APPAREILS

▲ MISE EN GARDE

Risque de pincement

L'installation de panneaux de porte avec un espacement de moins de 3/8 po (0,95 cm) entre le panneau de porte et l'armoire adjacente augmente le risque de pincement.

CONFIGURATIONS À 2 APPAREILS PERMISES

Trousse de joint poignée
à poignée
(JAJ13HSS)

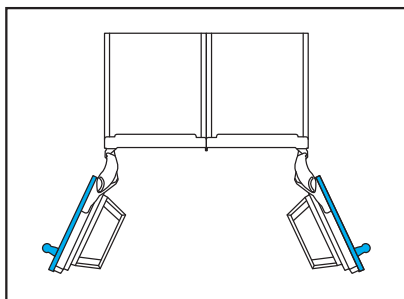

Trousse de joint charnière
à poignée
(JAJ12HSS)

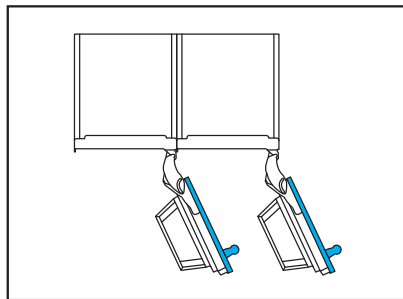

Trousse de joint poignée
à charnière
(JAJ11HSS)

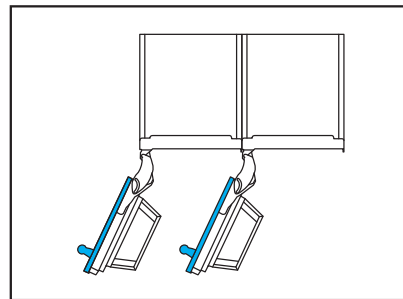

CONFIGURATIONS À 2 APPAREILS NON PERMISES

Charnière à charnière

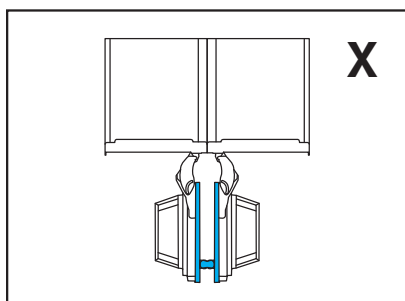

CONFIGURATIONS

3 APPAREILS

CONFIGURATIONS À 3 APPAREILS PERMISES

Trousses de joint poignée
à charnière et poignée
à charnière :
JAJ11HSS (X2)

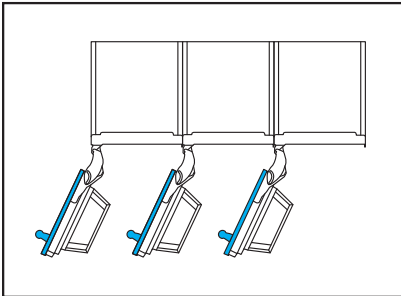

Trousses de joint charnière
à poignée et charnière
à poignée :
JAJ12HSS (x2)

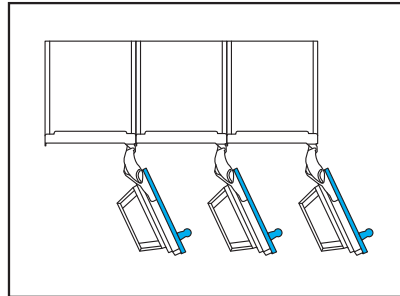

Trousses de joint poignée à charnière
et poignée à poignée :
JAJ11HSS et JAJ13HSS

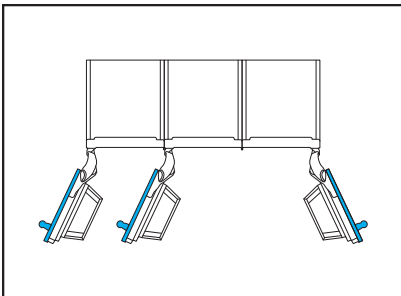

Trousses de joint poignée à poignée
et charnière à poignée :
JAJ13HSS et JAJ12HSS

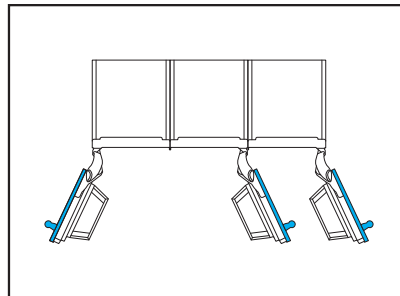

CONFIGURATIONS À 3 APPAREILS NON PERMISES

Charnière à charnière

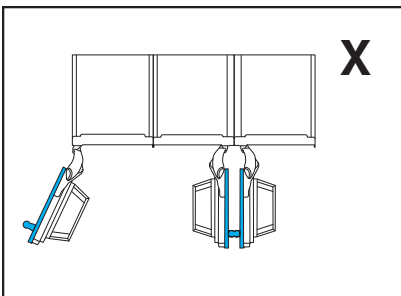

Charnière à charnière

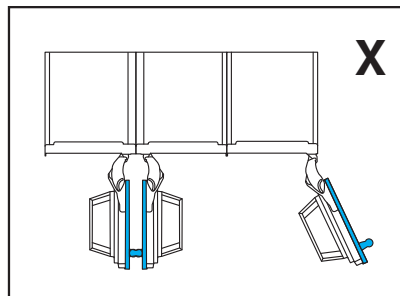

DIMENSIONS

PRODUIT

DIMENSIONS COMPLÈTES SANS PANNEAU

Largeur	Voir le tableau de largeur de l'appareil suivant
Hauteur	79 7/8 po à 85 5/16 po (202,9 cm à 215,9 cm)
Profondeur	24 1/8 po (61,3 cm)
Hauteur de porte brute	79 7/8 po (202,9 cm)
Hauteur de la plinthe	3 9/16 po (9,1cm)
Profondeur de la plinthe	3 1/4 po à 4 7/8 po (8,3 cm à 12,4 cm)

LARGEUR DU PRODUIT

Modèle	Largeur
18 po JBZFR18IGX JBZFL18IGX ALOVE18FL	17 3/4 po (45,1 cm)
24 po JBRFR24IGX JBRFL24IGX JBZFR24IGX JBZFL24IGX ALOVE24FL ALOVE24RR	23 3/4 po (60,3 cm)
30 po JBRFR30IGX JBRFL30IGX JBZFR30IGX JBZFL30IGX ALOVE30RR	29 3/4 po (75,6 cm)
36 po JBRFR36IGX JBRFL36IGX	35 3/4 po (90,8 cm)

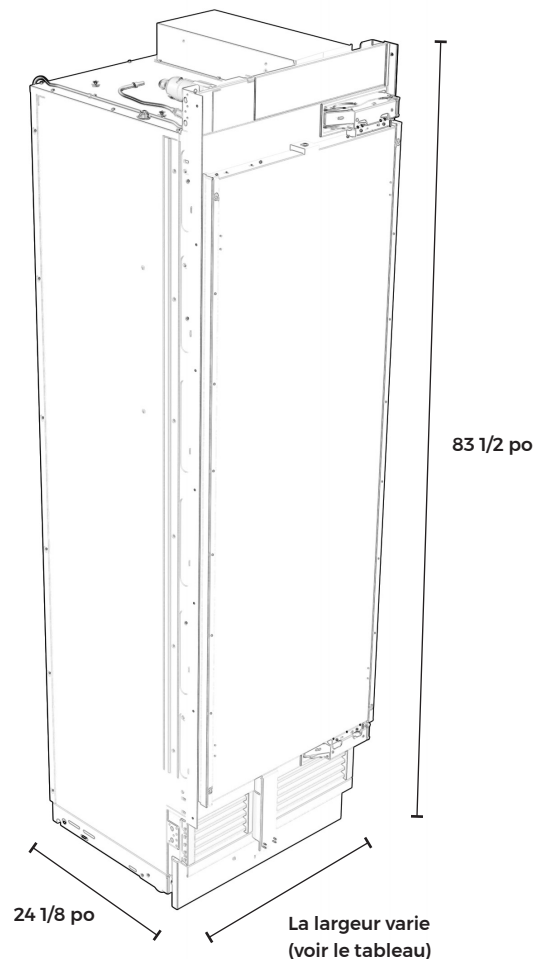

DIMENSIONS

ACCESSOIRES

PANNEAU EN ACIER INOXYDABLE

Hauteur	80 po (203,2 cm)
Épaisseur	13/16 po (2,1 cm)

PANNEAU PERSONNALISÉ

Épaisseur	3/4 po (1,9 cm) m ax.
Poids	60 lb (27,2 kg) m ax.
Hauteur habituelle	80 po (203,2 cm)

PLINTHE PERSONNALISÉE

Hauteur	3 9/16 po (9,1 cm)
Épaisseur	3/16 po à 3/4 po (4,8 mm à 1,9 mm)

STYLE DE PORTE

LARGEUR DU PANNEAU PERSONNALISÉ

▲ MISE EN GARDE

Risque de pincement

L'installation de panneaux de porte avec un espacement de moins de 3/8 po (0,95 cm) entre le panneau de porte et l'armoire adjacente augmente le risque de pincement.

MODÈLE	LARGEUR EN AFFLEUREMENT
18 po	17 3/4 po (45,1cm)
24 po	23 3/4 po (63,5 cm)
30 po	29 3/4 po (75,6 cm)
36 po	35 3/4 po (90,8 cm)

MODÈLE	LARGEUR SUPERPOSÉE
18 po	18 3/8 po (46,7 cm)
24 po	24 3/8 po (61,9 cm)
30 po	30 3/8 po (77,2 cm)
36 po	36 3/8 po (92,4 cm)

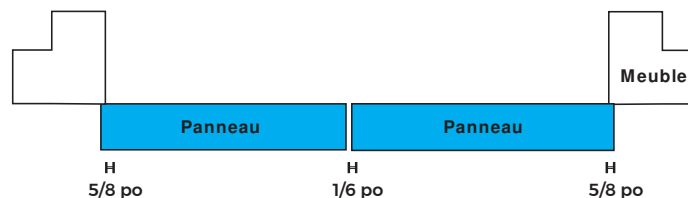
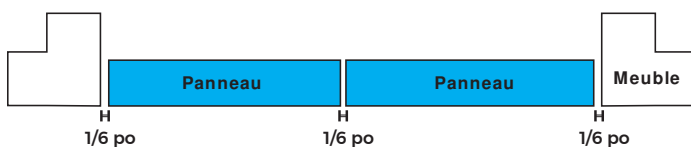

MODÈLE	LARGEUR EN AFFLEUREMENT
18 po	17 3/4 po (45,1cm)
24 po	23 3/4 po (63,5 cm)
30 po	29 3/4 po (75,6 cm)
36 po	35 3/4 po (90,8 cm)



DIMENSIONS

OUVERTURE

CONFIGURATION À 2 APPAREILS

REMARQUE : Ces schémas présentent les largeurs d'ouvertures pour des combinaisons d'appareils.

Les appareils peuvent être positionnés selon les différentes combinaisons permises présentées aux pages 124 et 125.

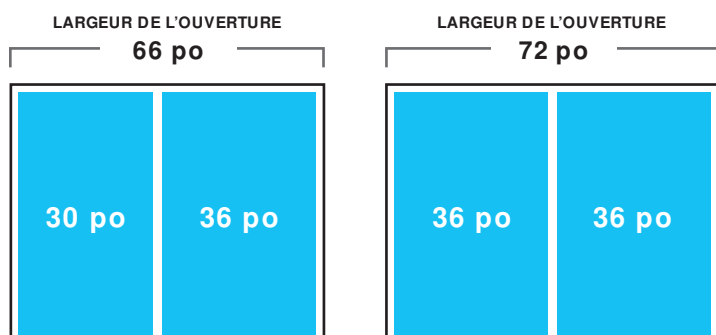
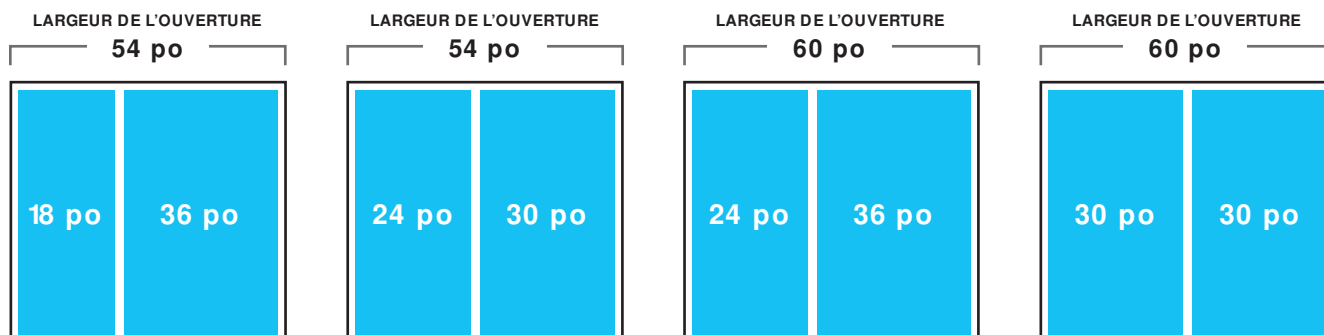
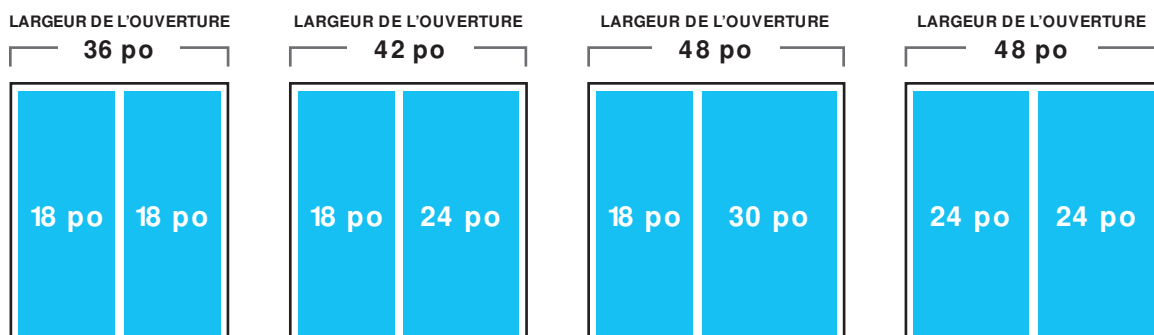

DIMENSIONS

OUVERTURE

CONFIGURATION À 3 APPAREILS

REMARQUE : Ces schémas présentent les largeurs d'ouvertures pour des combinaisons d'appareils.

Les appareils peuvent être positionnés selon les différentes combinaisons permises présentées aux pages 124 et 125.

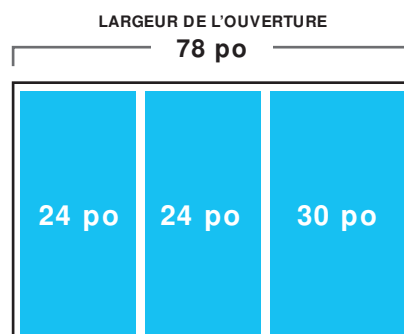
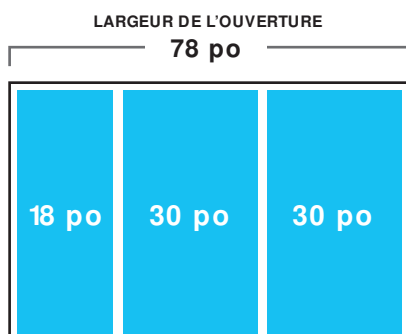
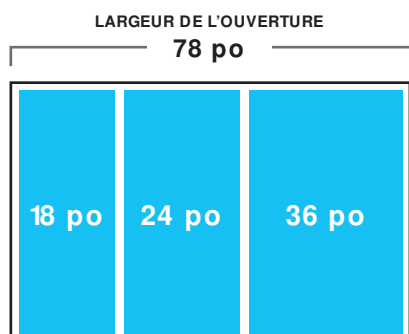
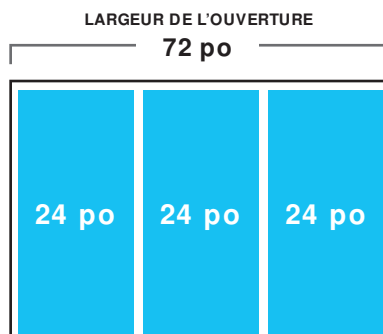
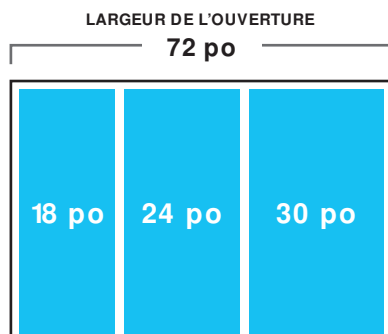
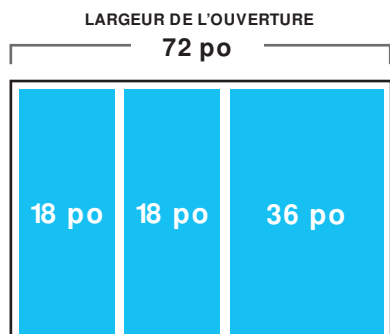
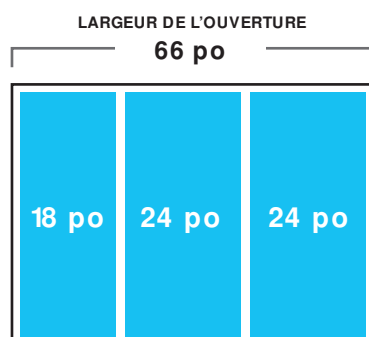
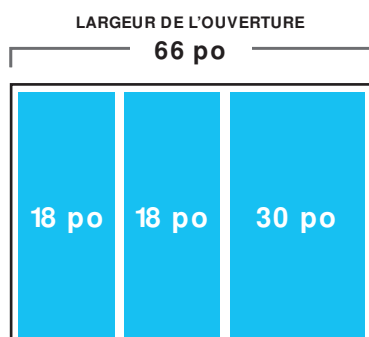
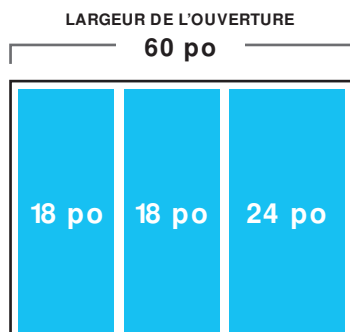
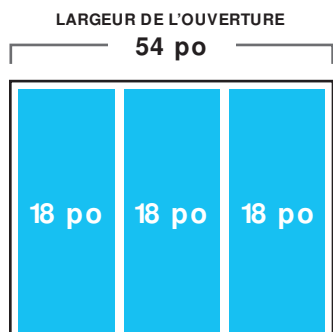

DIMENSIONS

OUVERTURE

CONFIGURATION À 3 APPAREILS

REMARQUE : Ces schémas présentent les largeurs d'ouvertures pour des combinaisons d'appareils.

Les appareils peuvent être positionnés selon les différentes combinaisons permises présentées aux pages 10 et 11.

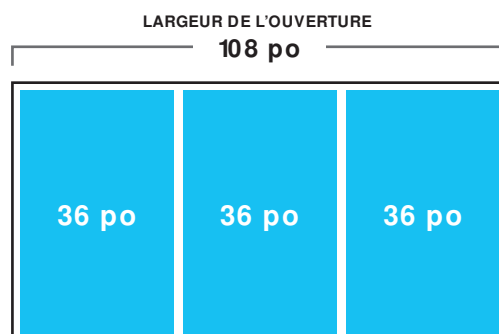
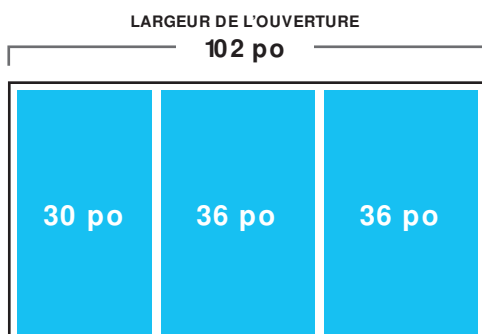
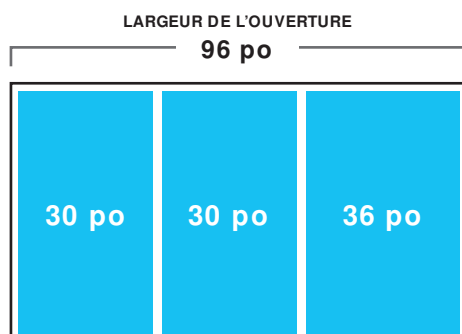
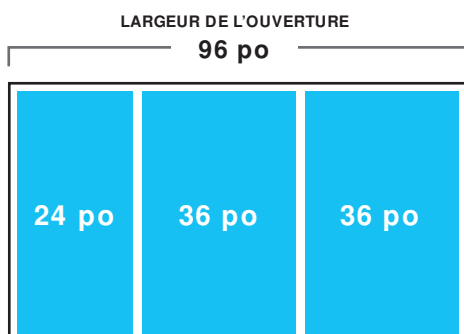
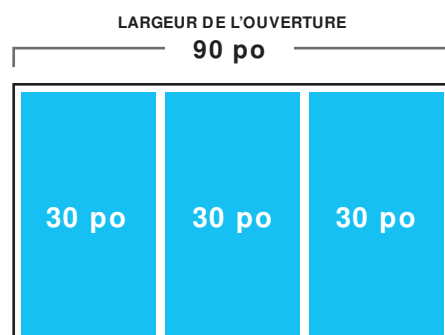
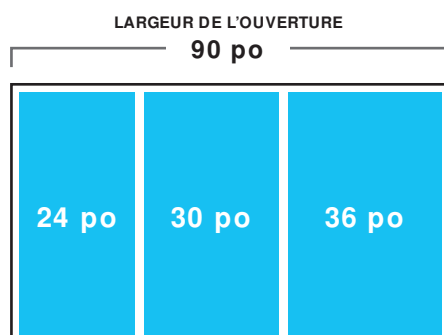
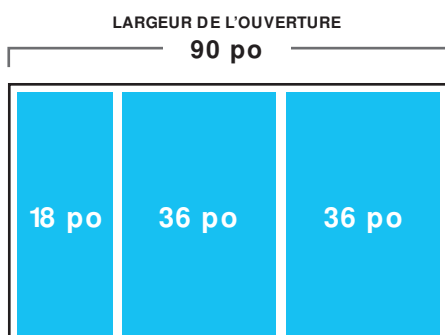
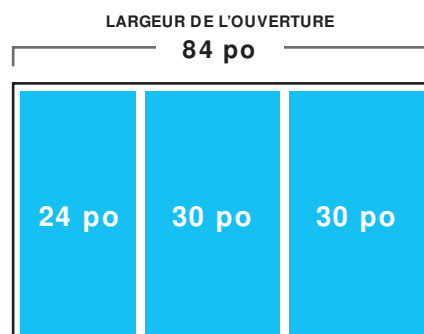
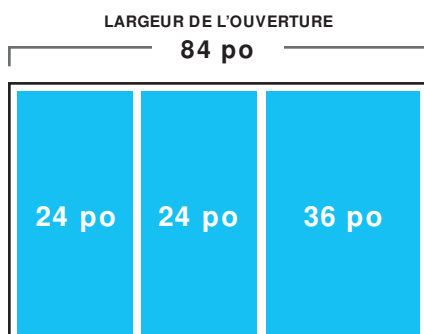
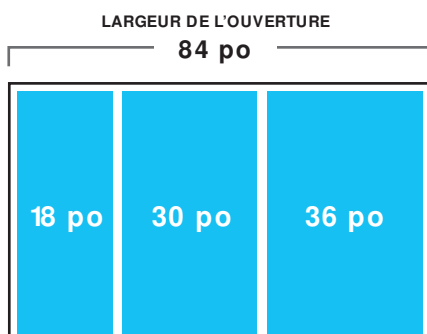

DIMENSIONS

OUVERTURE

▲ MISE EN GARDE

Risque de pincement
L'installation de panneaux de porte avec un espacement de moins de 3/8 po (0,95 cm) entre le panneau de porte et l'armoire adjacente augmente le risque de pincement.

EXIGENCES POUR L'OUVERTURE DE LA PORTE

Modèle	Ouverture de porte à 115° (A)	Ouverture de porte à 90° (B)	Espace avec le mur (C)	Profondeur d'ouverture de porte (D)
18 po	10 1/2 po (26,7 cm)	5 po (12,7 cm)	2 1/2 po (6,4 cm)	44 1/2 po (113 cm)
24 po	13 po (33 cm)	5 po (12,7 cm)	2 1/2 po (6,4 cm)	50 1/2 po (128,3 cm)
30 po	15 1/2 po (39,4 cm)	5 po (12,7 cm)	2 1/2 po (6,4 cm)	56 3/8 po (143,2 cm)
36 po	18 po (45,7 cm)	5 po (12,7 cm)	2 1/2 po (6,4 cm)	62 7/16 po (158,6 cm)

Les dimensions indiquent 2 1/2 po d'espace entre la poignée en acier inoxydable et le mur pour éviter les pincements. Si un panneau de bois personnalisé est utilisé, prendre en considération la profondeur de la poignée pour conserver un espace de 2 1/2 po.

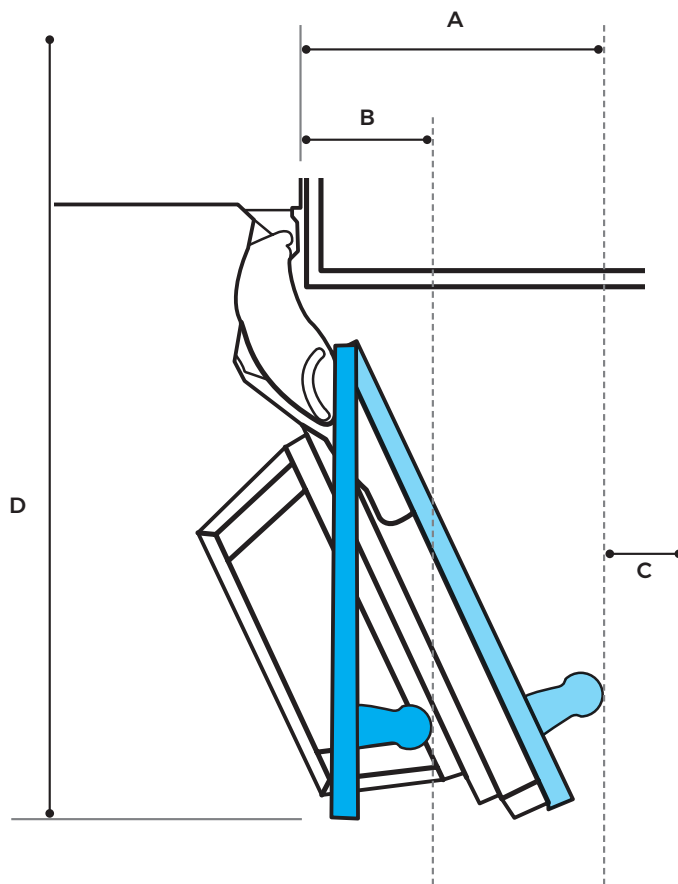

DIMENSIONS

OUVERTURE

LARGEUR DE L'OUVERTURE

Modèle	Largeur (A)
18 po JBZFR18IGX JBZFL18IGX ALOVE18FL	18 po (45,7 cm)
24 po JBRFR24IGX JBRFL24IGX JBZFR24IGX JBZFL24IGX ALOVE24FL ALOVE24RR	24 po (61 cm)
30 po JBRFR30IGX JBRFL30IGX JBZFR30IGX JBZFL30IGX ALOVE30RR	30 po (76,2 cm)
36 po JBRFR36IGX JBRFL36IGX	36 po (91,4 cm)

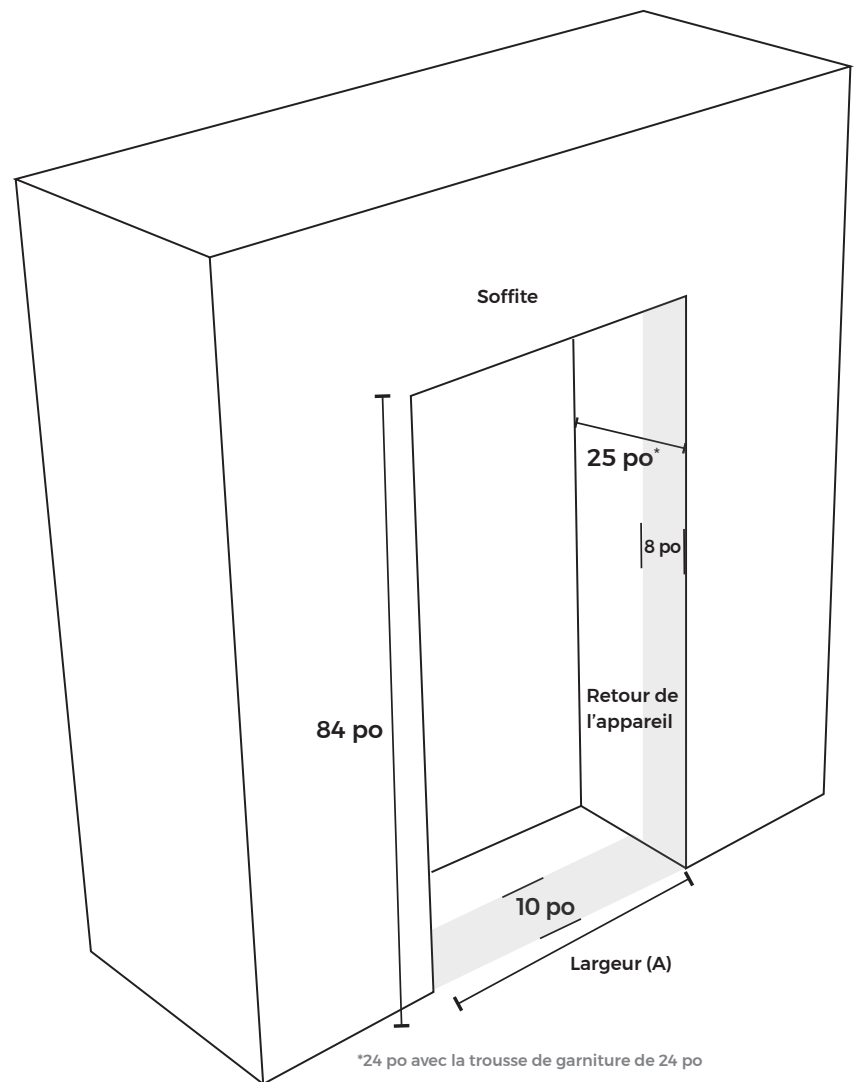

PRÉPARATION DU SITE

1. VÉRIFICATION DU MEUBLE

- Mesurer pour s'assurer que toutes les dimensions de l'ouverture sont bonnes. (Voir la page précédente.)
- Fabrication du panneau latéral : Contreplaqué de 3/4 po (1,9 cm) d'épaisseur.
IMPORTANT : Ne peut pas être fabriqué en fibres pressées comme le MDF.
- Hauteur du soffite : 84 po (213,4 cm).
- Un tuyau d'alimentation d'eau unique peut être séparé en 2 ou 3 pour alimenter tous les appareils.

⚠ AVERTISSEMENT



Risque d'explosion

Garder les matériaux et les vapeurs inflammables, telle que l'essence, loin du réfrigérateur.

Le non-respect de cette instruction peut causer un décès, une explosion ou un incendie.

2. VÉRIFICATION DU SITE D'INSTALLATION

- Loin des fours, radiateurs et autres sources de chaleur.
- La température ne descend pas sous 55 °F (13 °C).
- Le plancher doit pouvoir supporter plus de 600 lb. (272 kg) en plus des panneaux de porte et du contenu.
- Le plancher doit être d'aplomb avec la pièce.
- L'aplomb de l'avant du meuble.

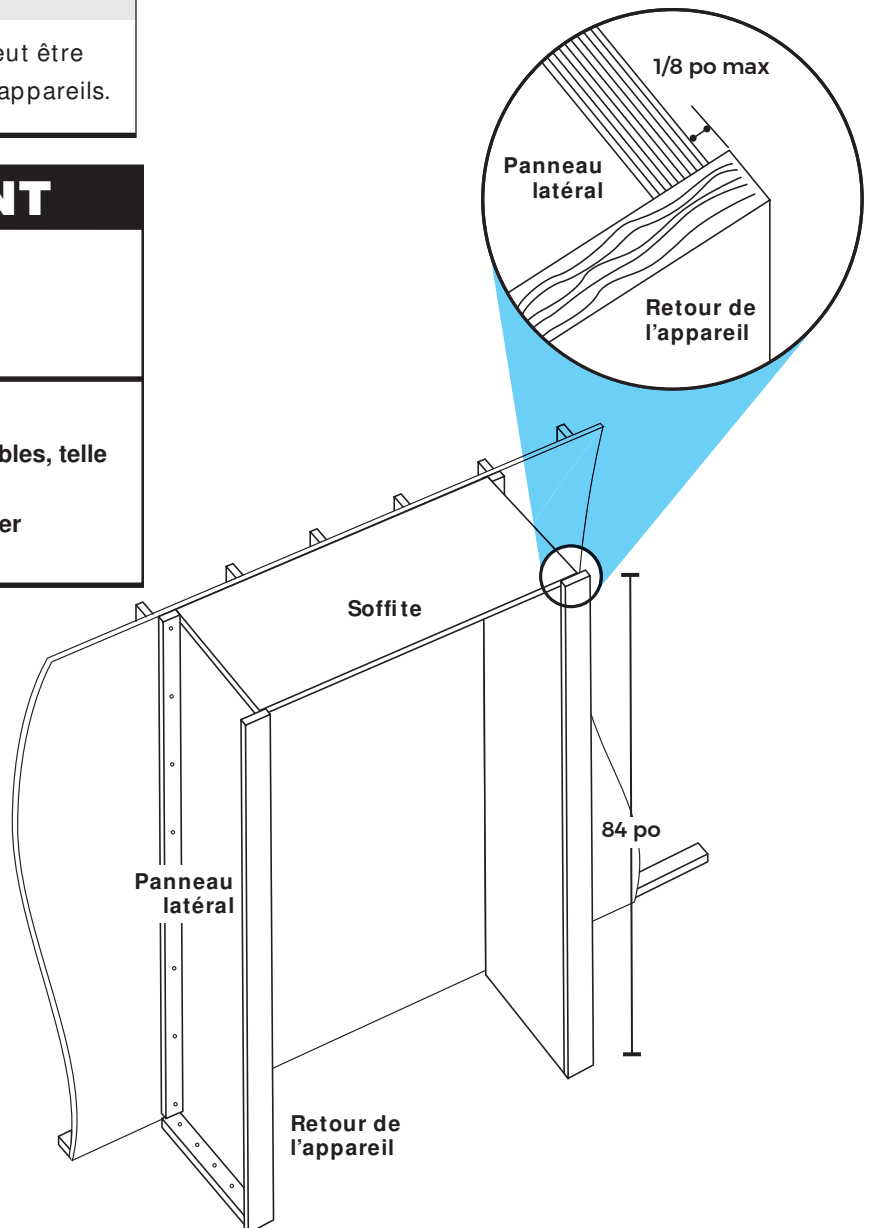

PRÉPARATION DU SITE

3. VÉRIFICATION DE L'ARRIVÉE D'EAU

- L'arrivée d'eau respecte les codes de plomberie locaux.
- Le robinet d'arrêt situé dans l'armoire du bas est placé comme indiqué ou situé dans un espace accessible.
- Le trou d'accès à travers l'armoire se trouve à moins de 1/2 po (1,3 cm) du mur arrière.
- N'installer de tuyaux supplémentaires que si la température reste au-dessus du point de congélation. Vérifier qu'il n'y a pas de fuites.
- Ne pas utiliser de robinet à étrier de 3/16 po (4,8 mm) ou de type à percer. Consulter un marchand de réfrigérateurs pour obtenir une trousse avec robinet d'arrêt à étrier qui respecte les codes de plomberie locaux.
- Si la pression d'eau au système de filtration par osmose inverse est inférieure à 40 - 60 lb/po (276 - 414 kPa) :
 - Vérifier le filtre à sédiment pour s'assurer qu'il n'est pas obstrué. Remplacer le filtre si nécessaire.
 - Laisser le réservoir se remplir après une utilisation intense.
 - Enlever la cartouche de filtre à eau.
Aucune dérivation de filtre n'est nécessaire.

SPÉCIFICATIONS DE L'ALIMENTATION EN EAU

Pression d'eau	30 à 120 lb/po ² (207 à 827 kPa)
Pression de l'eau au système d'osmose inverse	40 à 60 lb/po ² (276 à 414 kPa) minimum
Excédent de canalisation d'eau pour le raccordement	30 po (76,2 cm)
Alimentation	Tuyau en cuivre, à tresse d'acier inoxydable ou PEX d'un diamètre extérieur de 1/4 po

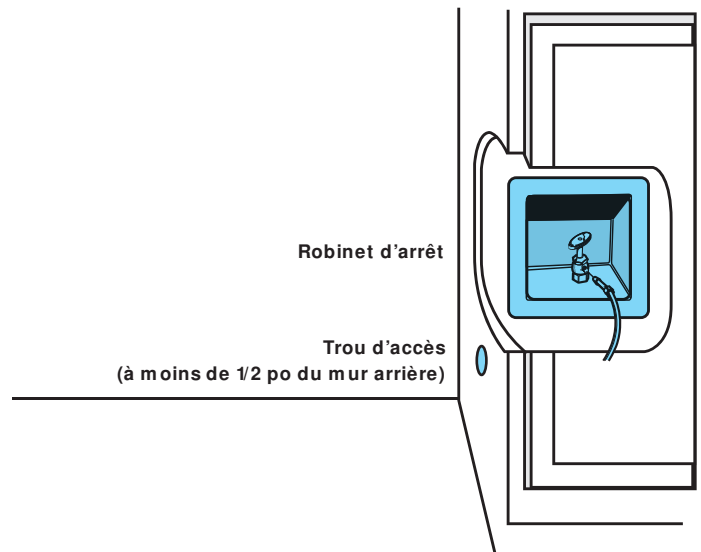

POUR TOUTE QUESTION AU SUJET DE L'ALIMENTATION EN EAU, FAIRE APPEL À UN PLOMBIER QUALIFIÉ AGRÉÉ.

PRÉPARATION DU SITE

⚠ AVERTISSEMENT



Risque de choc électrique

Brancher sur une prise à 3 alvéoles reliée à la terre.

Ne pas enlever la broche de liaison à la terre.

Ne pas utiliser un adaptateur.

Ne pas utiliser un câble de rallonge.

Le non-respect de ces instructions peut causer un décès, un incendie ou un choc électrique.

SPÉCIFICATIONS ÉLECTRIQUES

Largeur du produit/largeur "A" de zone électrique alternative	Largeur de la zone électrique (B)
18 po (45,7 cm)	14 1/2 po (36,8 cm)
24 po (60,1 cm)	20 1/2 po (52 cm)
30 po (76,2 cm)	26 1/2 po (67,3 cm)
36 po (91,4 cm)	32 1/2 po (82,6 cm)

4. VÉRIFICATION DE L'ÉLECTRICITÉ

- L'appareil doit être branché sur un circuit séparé. L'alimentation de la prise de courant ne doit pas être interrompue par un interrupteur.
- Ne pas utiliser de rallonge.
- Ne pas utiliser de prise avec disjoncteur différentiel.
- Installer l'électricité dans la zone indiquée. (Voir l'illustration de droite.)

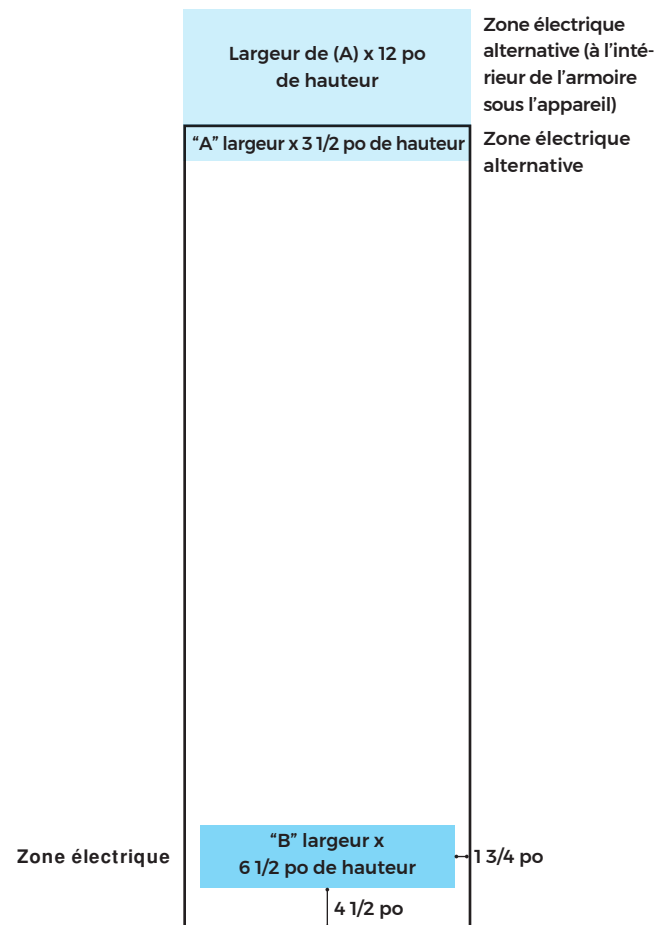

? POUR TOUTE QUESTION AU SUJET DE L'ALIMENTATION ÉLECTRIQUE, FAIRE APPEL À UN ÉLECTRICIEN QUALIFIÉ AGRÉÉ.

PRÉPARATION DU SITE

5. VÉRIFICATION AVANT L'INSTALLATION

- Vérifier le type de porte choisi par le client.
- Enlever tout le matériel d'installation du tiroir pour spécialités.
- Marquer le style de porte sur les gabarits et gabarits de profondeur de porte à l'aide d'un marqueur indélébile.
- Vérifier que les mesures diagonales de l'ouverture correspondent.
- Consulter le document de considérations de conception pour vérifier les dimensions du panneau et de la plinthe, ainsi que les espaces et superpositions.
- S'assurer d'avoir les bonnes trousse de joint pour la configuration, côté gauche/droit, charnière/sans charnière et ordre d'installation.

INSTRUCTIONS IMPORTANTES

Ces instructions importantes vous indiquent où effectuer les étapes des sections suivantes.

À noter que les appareils sont installés et numérotés de gauche à droite.

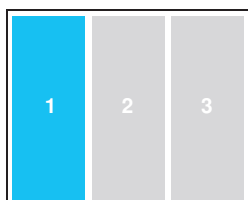

Commencer par l'étape de l'appareil indiqué en bleu.

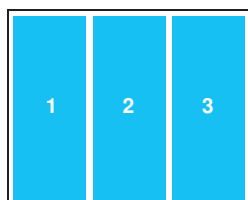

Effectuer l'étape pour tous les appareils installés.

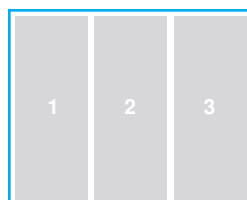

Effectuer l'étape du meuble.

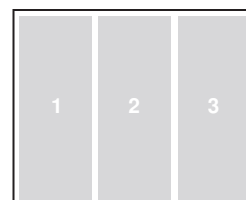

Effectuer l'étape sans lien avec l'appareil, comme pour le panneau ou la plinthe.

RÉPARATION

DES APPAREILS

1.1

DÉBALLER L'APPAREIL ET LES TROUSSES DE JOINT, JETER LES CARTONS.

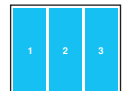
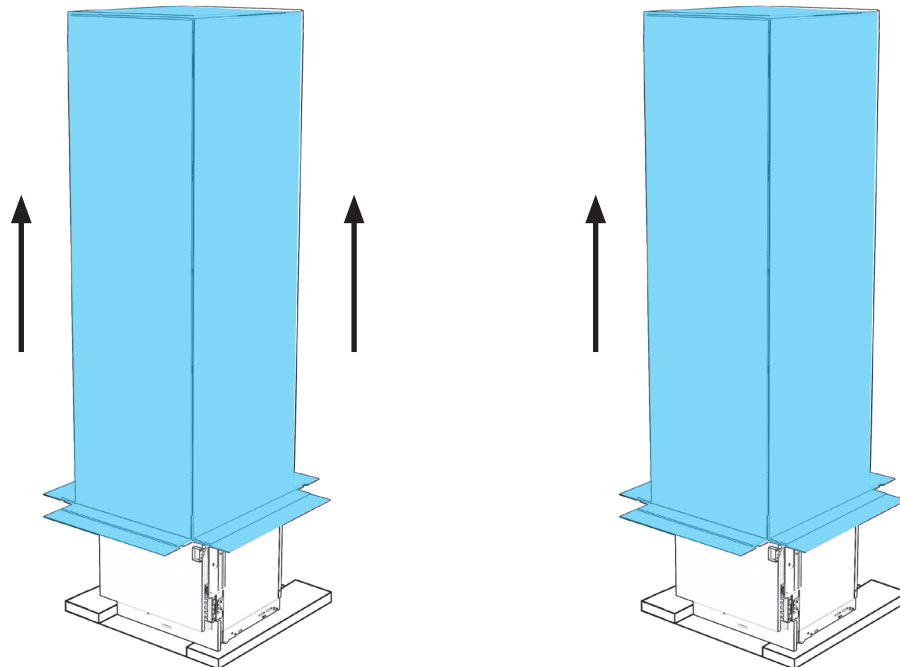

RETIRER LES TROUSSES D'INSTALLATION DU TIROIR DES TIROIRS POUR SPÉCIALITÉ PENDANT QUE L'APPAREIL EST TOUJOURS SUR SES PATINS.

AVANT DE DÉPLACER L'APPAREIL, LIRE TOUS LES AVERTISSEMENTS.

⚠ AVERTISSEMENT



Risque de basculement

Le réfrigérateur est lourd au sommet et bascule facilement lorsqu'il n'est pas complètement installé.

Garder les portes fermées avec un ruban adhésif jusqu'à l'installation complète du réfrigérateur.

Utiliser deux ou plus de personnes pour déplacer et installer le réfrigérateur.

Le non-respect de ces instructions peut causer un décès ou une blessure grave.

Déplacement de votre réfrigérateur :

Votre réfrigérateur est lourd. Lors du déplacement de votre réfrigérateur pour le nettoyage ou un entretien ou réparation, veiller à recouvrir le plancher avec du carton ou un panneau de fibres dures pour éviter qu'il ne subisse tout dommage. Toujours tirer le réfrigérateur tout droit lors de son déplacement. Ne pas incliner le réfrigérateur d'un côté ou de l'autre ni le "faire marcher" en essayant de le déplacer car le plancher pourrait être endommagé.

Importants renseignements à savoir au sujet des tablettes et des couvercles en verre :

Ne pas nettoyer les tablettes ou couvercles en verre avec de l'eau tiède quand ils sont froids. Les tablettes et les couvercles peuvent se briser s'ils sont exposés à des changements soudains de température ou à un impact tel que coup brusque. Le verre trempé est conçu pour éclater en d'innombrables pièces minuscules. Ceci est normal. Les tablettes et les couvercles en verre sont lourds. Les saisir à deux mains lors de leur dépose afin d'éviter de les faire tomber.

1

PRÉPARATION DES APPAREILS

1.2

POUR CHAQUE APPAREIL : DÉPLACER DEVANT L'OUVERTURE.

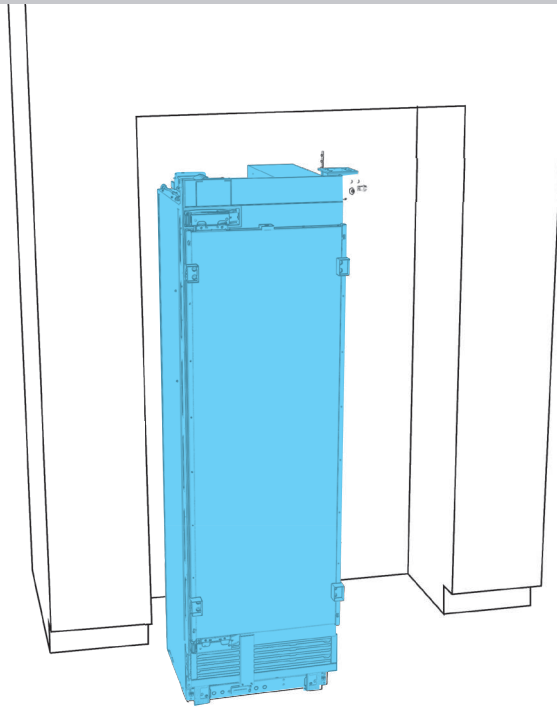

DÉPLACER L'APPAREIL À DEUX PERSONNES. NE PAS OUVRIR LES PORTES AVANT QUE L'APPAREIL SOIT SÉCURISÉ.

1.3

POUR CHAQUE APPAREIL : ENLEVER LES DEUX VIS DU FILTRE À EAU.

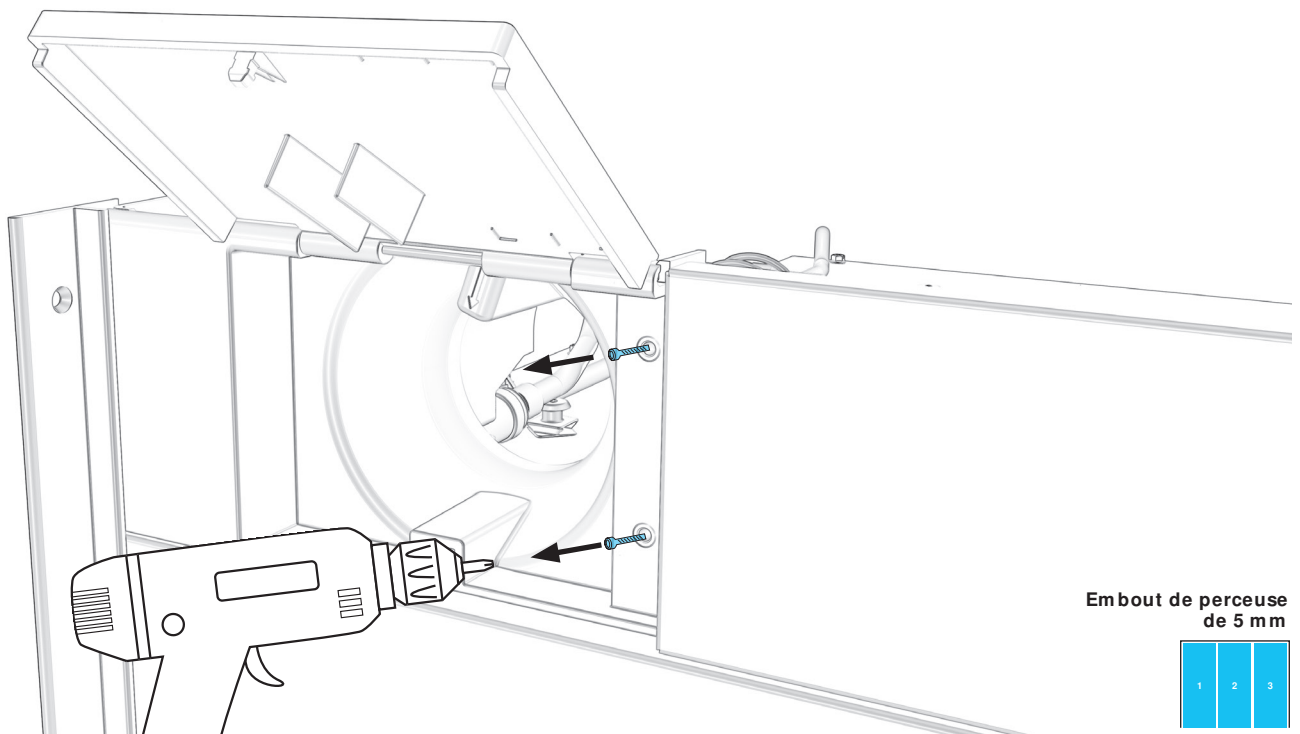

Embout de perceuse
de 5 mm

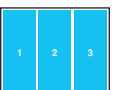

1.4

POUR CHAQUE APPAREIL : TIRER VERS LA GAUCHE, ENLEVER LA PLAQUE.

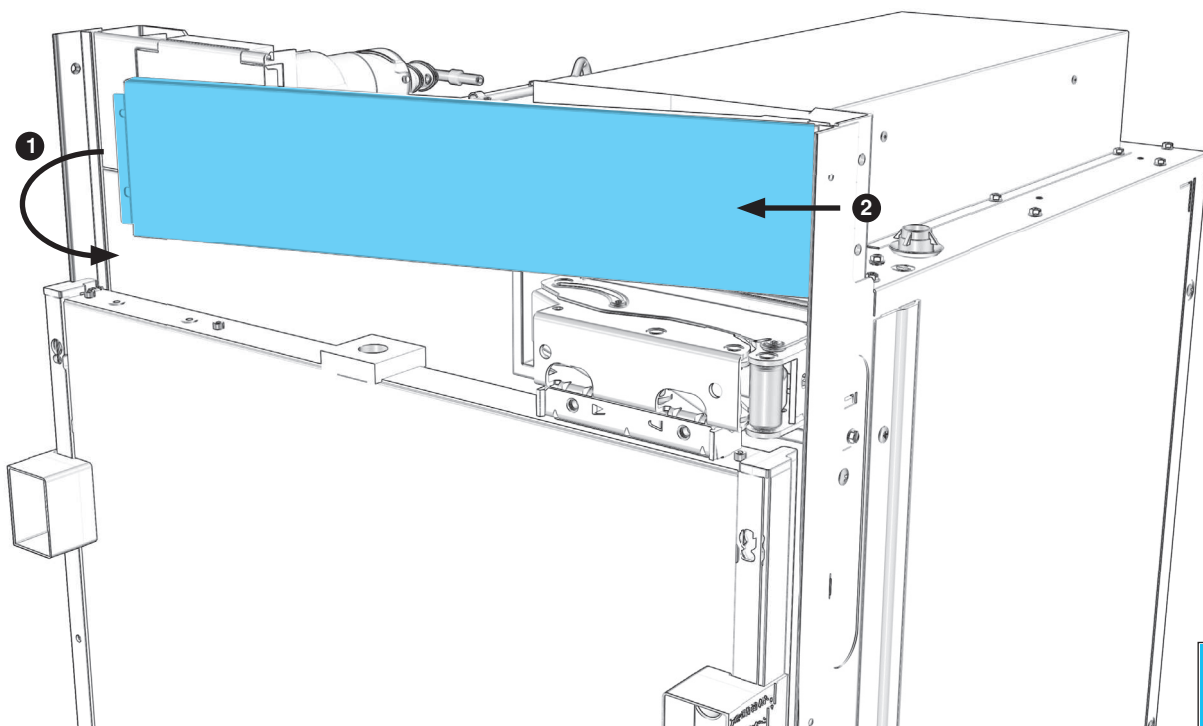

1.5

POUR CHAQUE APPAREIL : TIRER LE BOÎTIER VERS LA DROITE POUR L'ENLEVER.

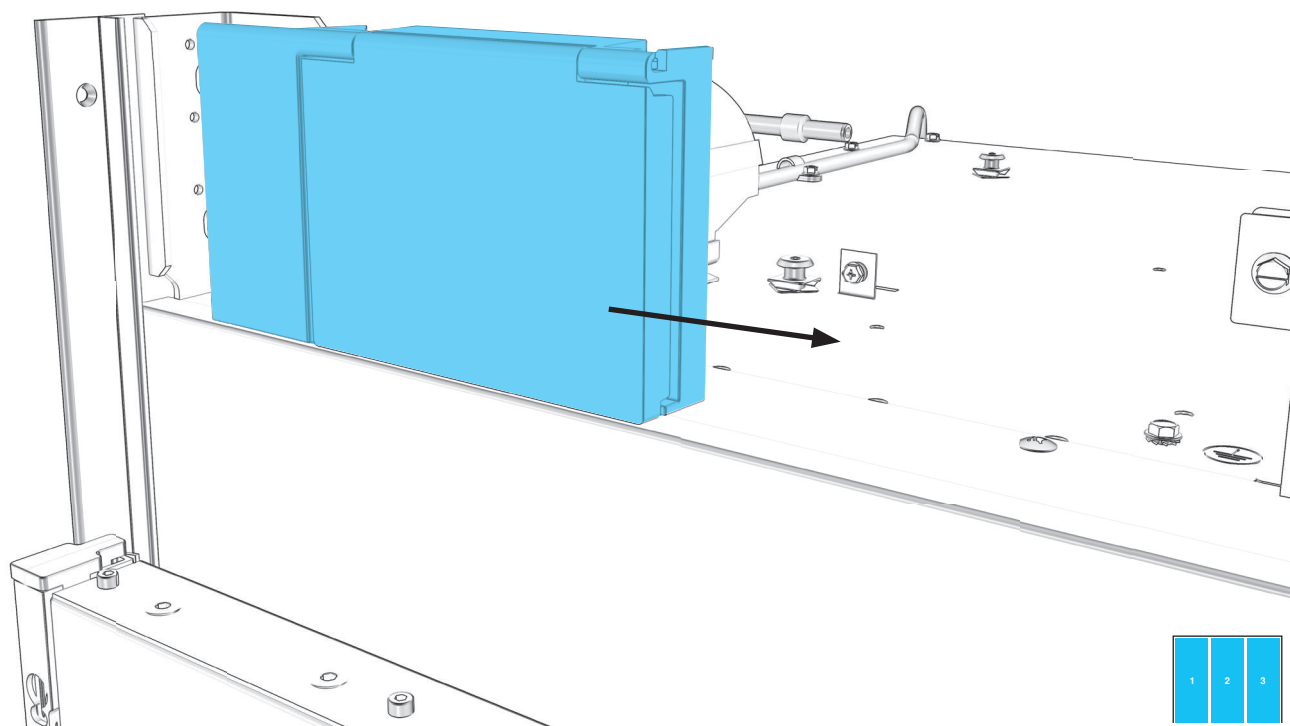

1

PRÉPARATION DES APPAREILS

1.6

POUR CHAQUE APPAREIL : RETIRER LES QUATRE VIS DE LA GRILLE D'AÉRATION.

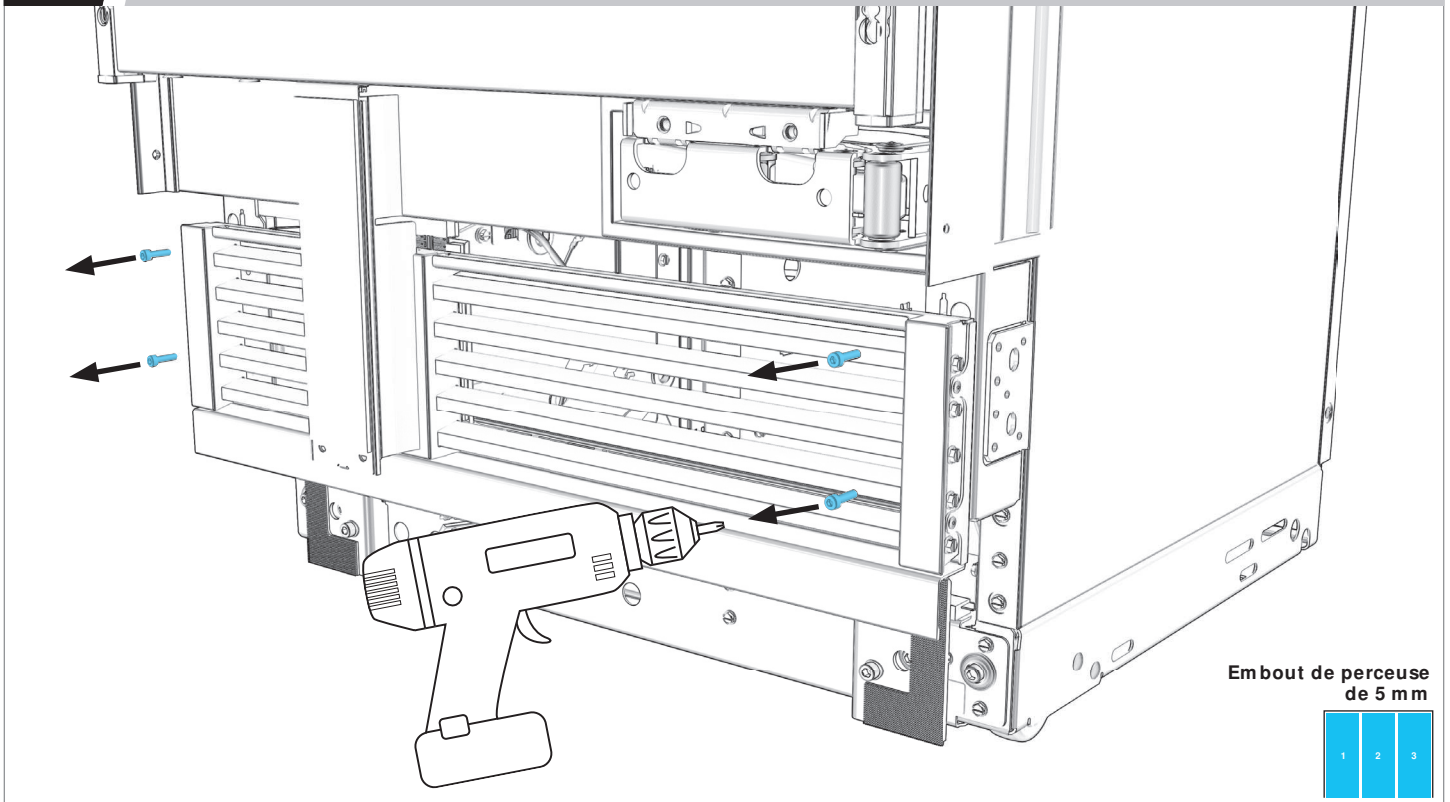

1.7

POUR CHAQUE APPAREIL : RETIRER LA GRILLE D'AÉRATION DE LA BASE.

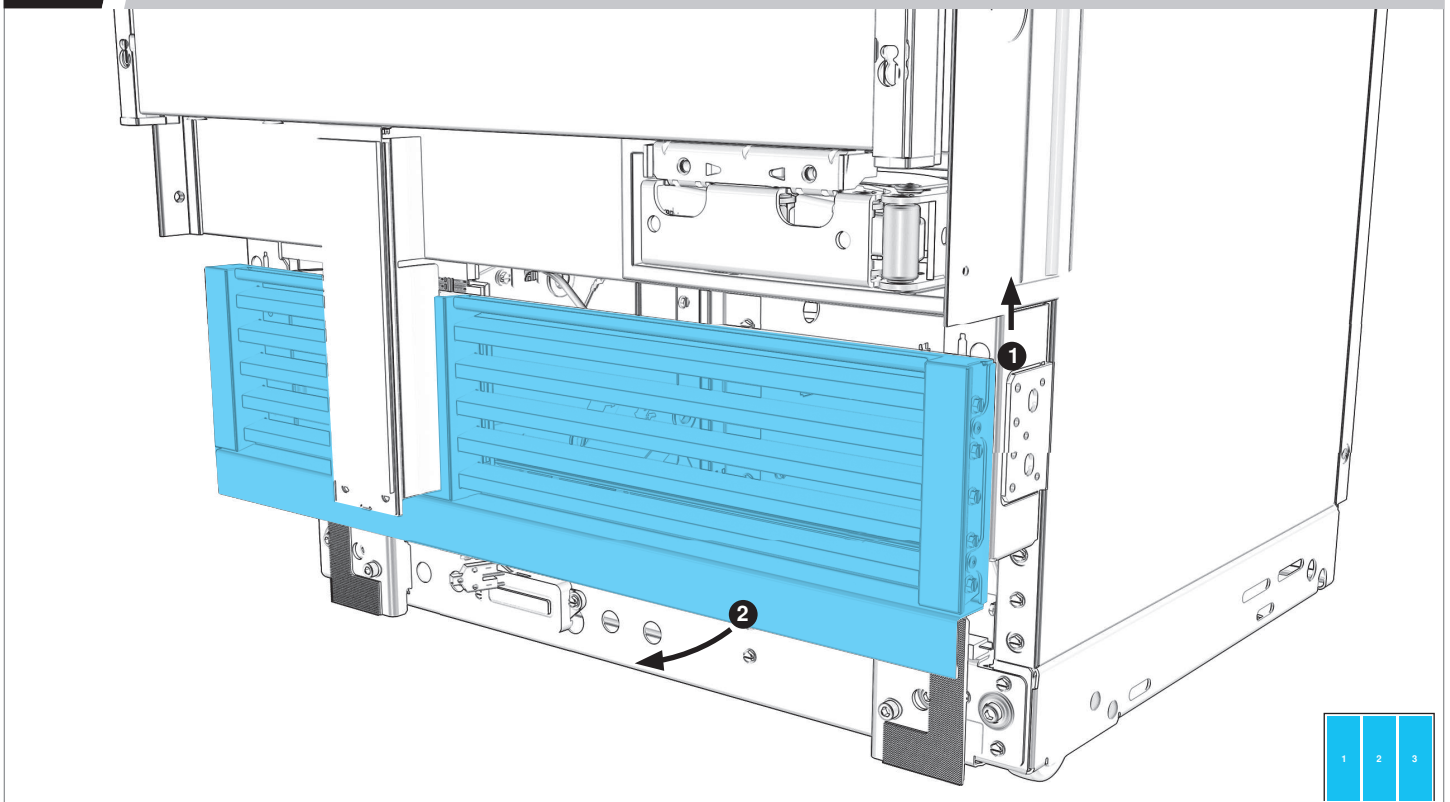

1.8

DEUXIÈME ET TROISIÈME APPAREIL : INSTALLER LA GARNITURE DE GRILLE D'AÉRATION.

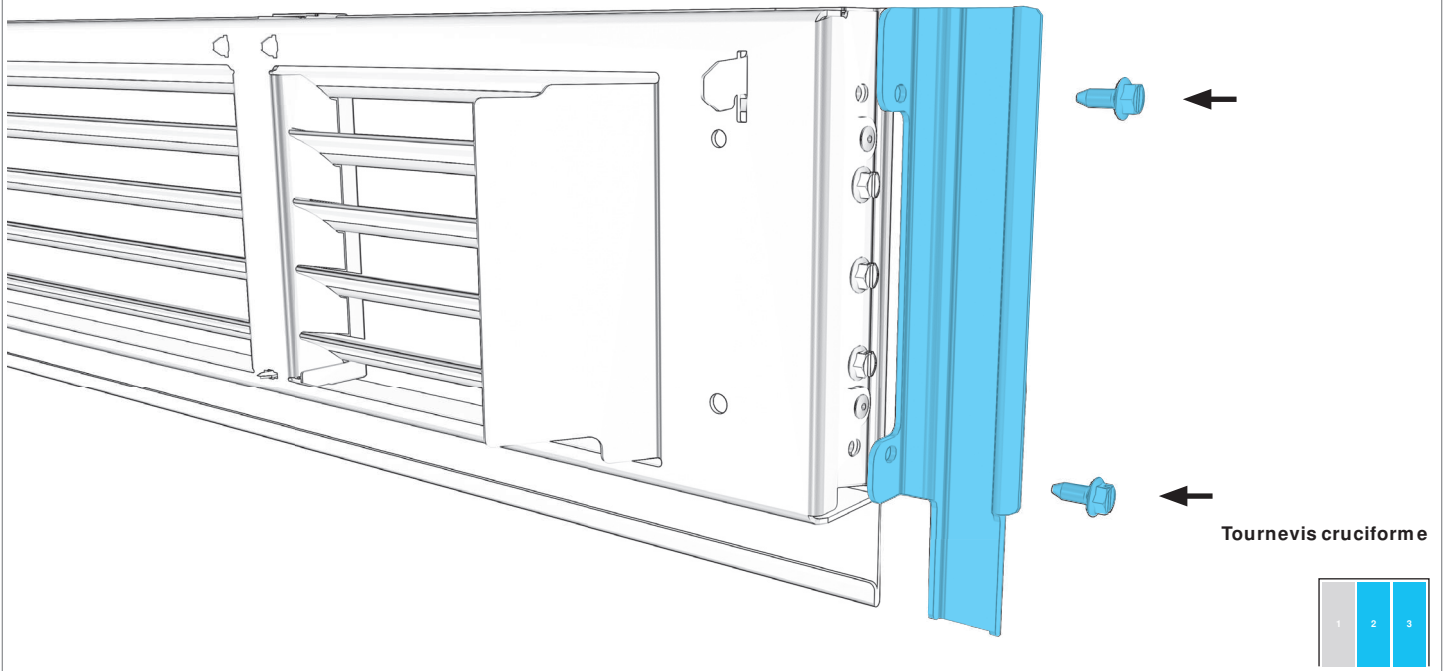

1.9

RETIRER LES GARNITURES ENTRE LES APPAREILS.

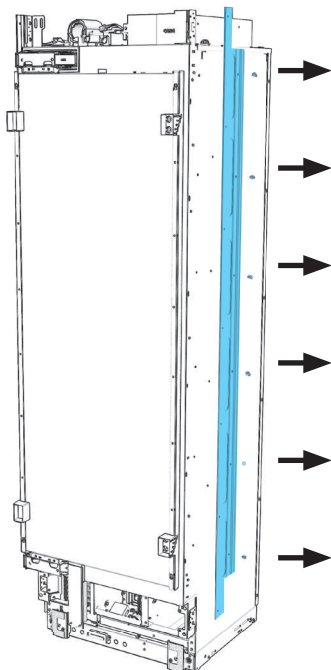

Retirer la garniture,
2 appareils

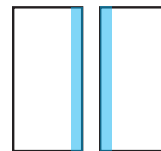

Retirer la garniture,
3 appareils

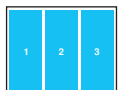
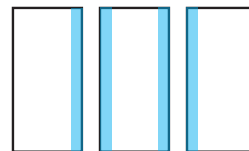

LAISSER LES GARNITURES EN PLACE SUR LES CÔTÉS MEUBLES.

1

PRÉPARATION DES APPAREILS

1.10

PREMIER APPAREIL : INSTALLER L'ESPACEUR.

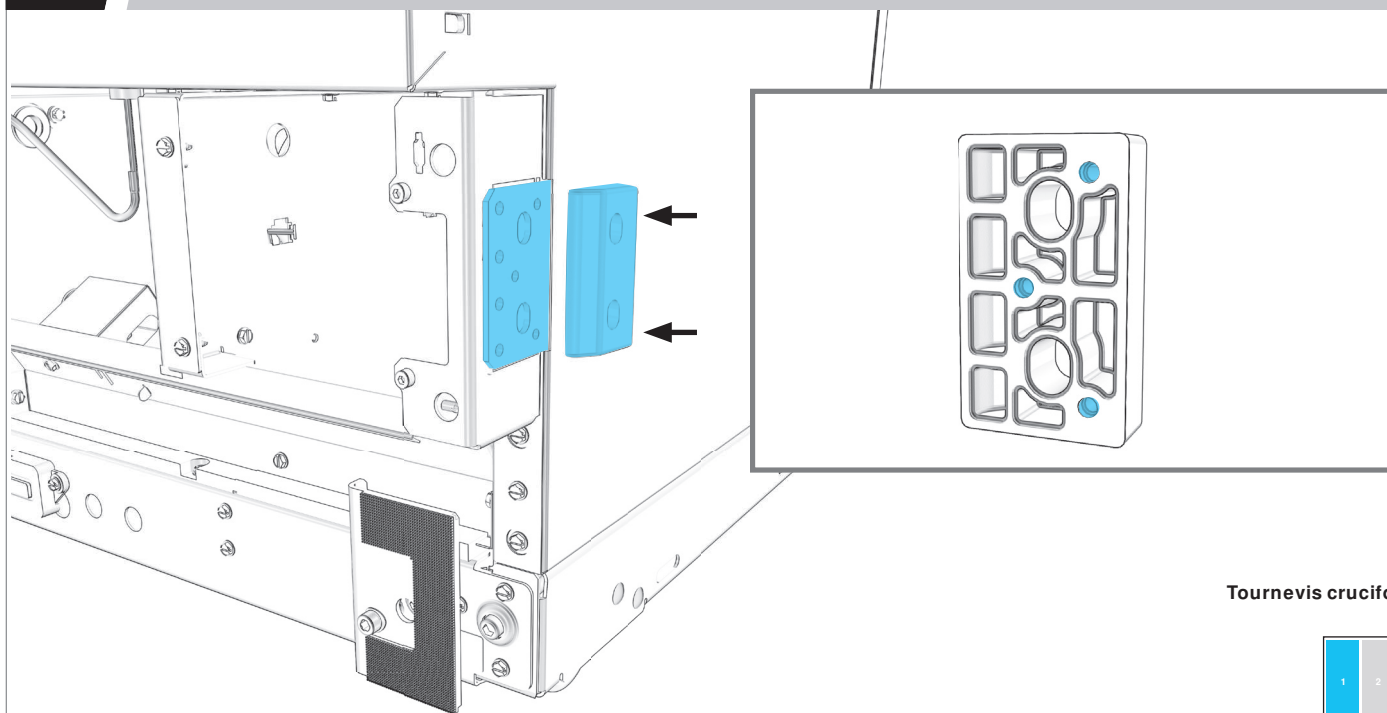

Tournevis cruciforme



S'ASSURER QUE LE CÔTÉ MINCE FAIT FACE VERS L'EXTÉRIEUR.

1.11

SI TROIS APPAREILS SONT INSTALLÉS : RÉPÉTER L'ÉTAPE 1.10 POUR LE DEUXIÈME APPAREIL.

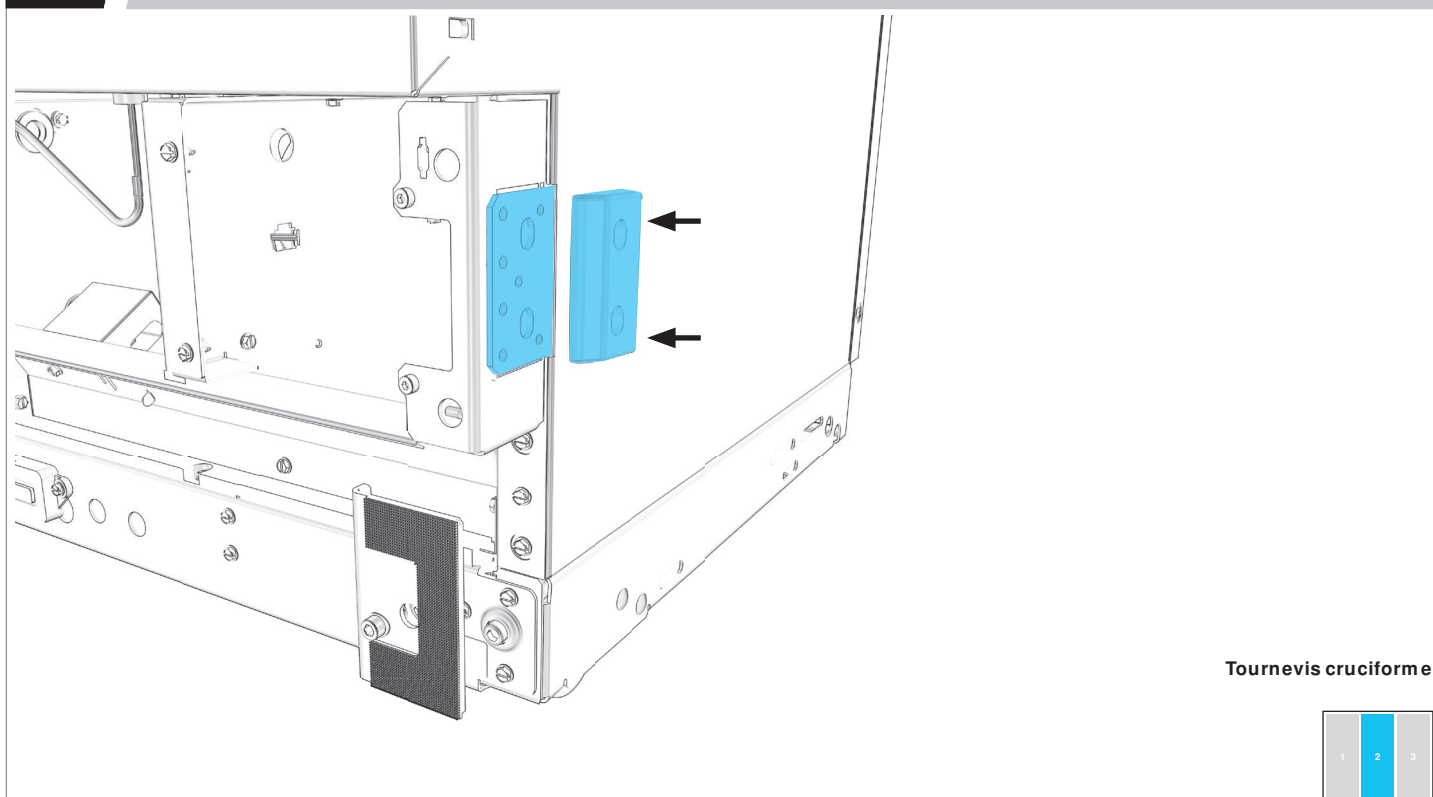

Tournevis cruciforme



PRÉPARATION

DE LA TROUSSE DE JOINT

2

PRÉPARATION DE LA TROUSSE DE JOINT

2.1

PREMIER APPAREIL : ALIGNER ET FIXER L'ÉLÉMENT CHAUFFANT.

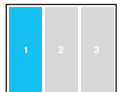
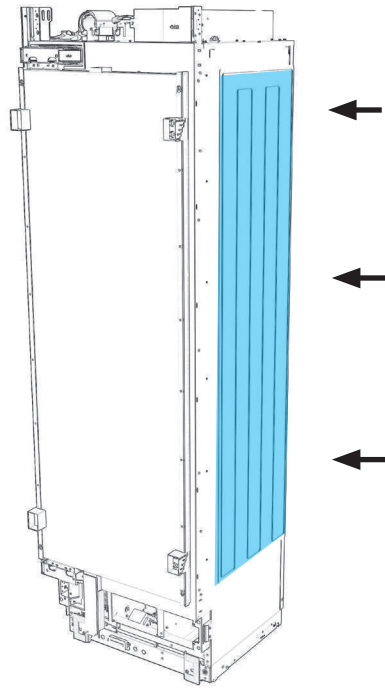

2.2

BRANCHER L'ÉLÉMENT CHAUFFANT SUR L'APPAREIL.

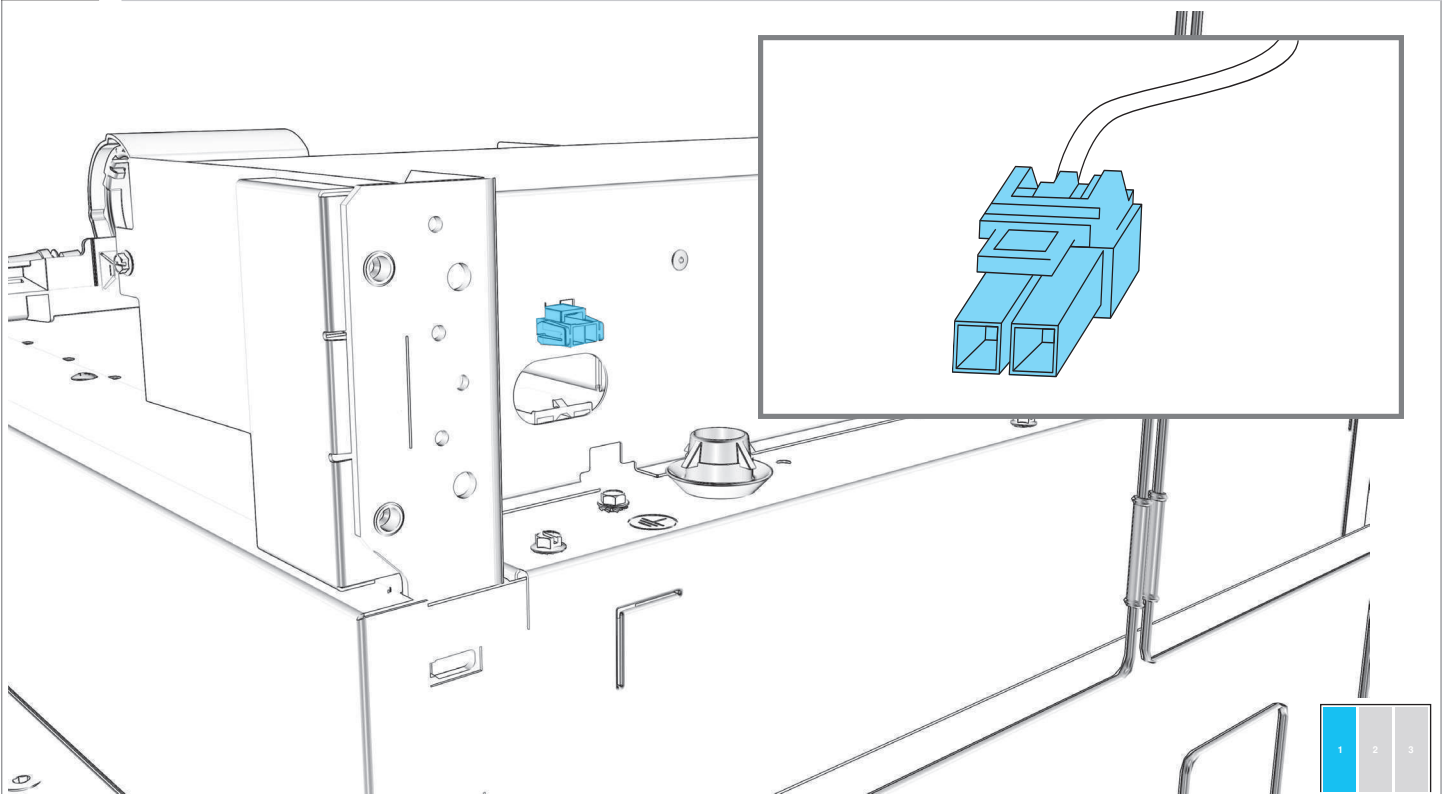

2.3

RÉPÉTER L'ÉTAPE 2.1 ET 2.2 AVEC LE DEUXIÈME APPAREIL.

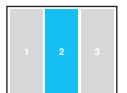
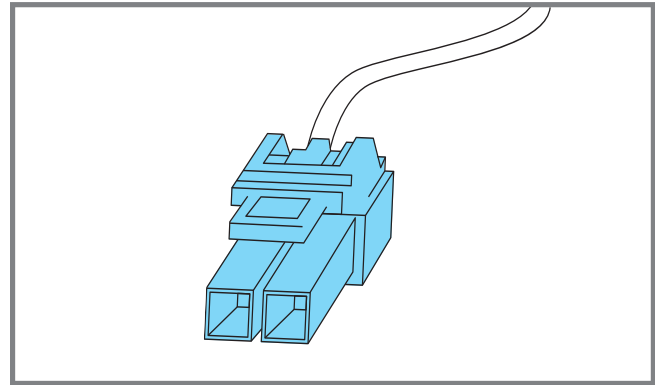
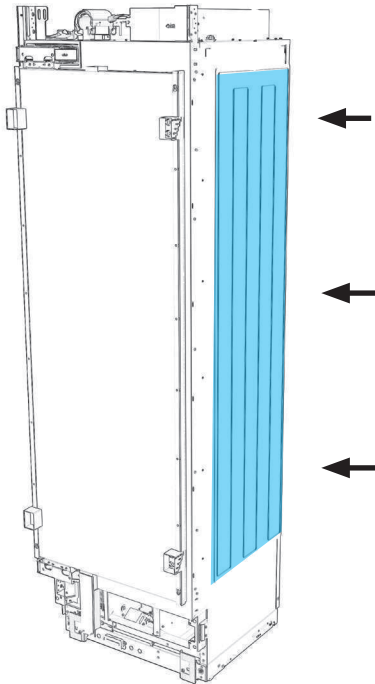

2.4

PREMIER APPAREIL : INSTALLER LA GARNITURE DE JOINT EN L.

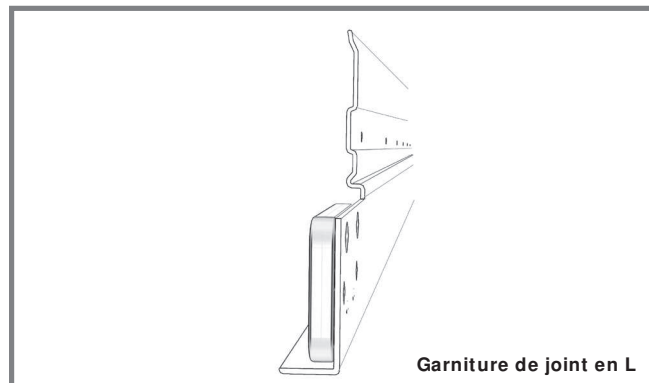
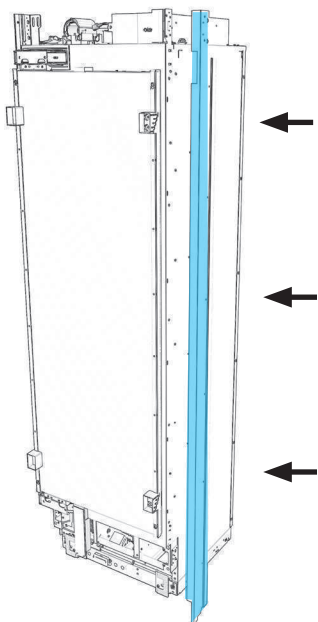

Tournevis cruciforme

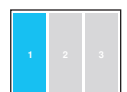

2

PRÉPARATION DE LA TROUSSE DE JOINT

2.5

DEUXIÈME APPAREIL : INSTALLER LA GARNITURE DE JOINT EN CROCHET.

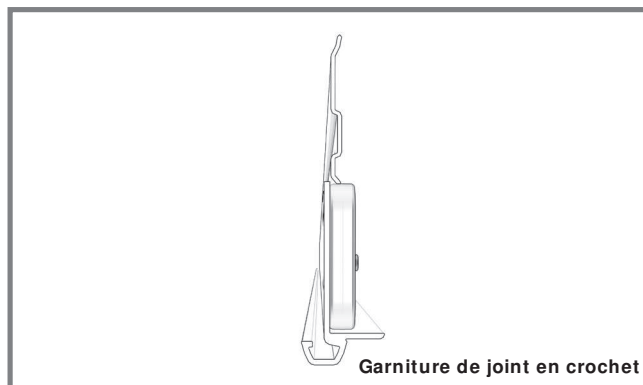
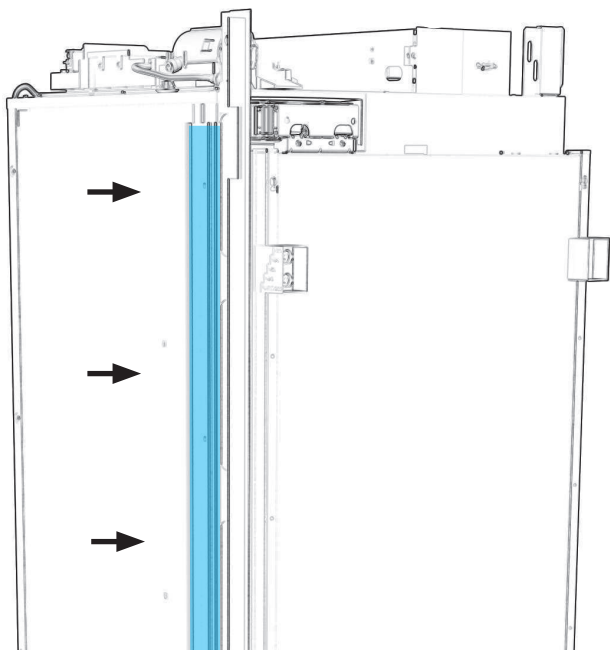

Garniture de joint en crochet

Tournevis cruciforme

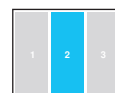

2.6

SI TROIS APPAREILS SONT INSTALLÉS : INSTALLER LE JOINT DE GARNITURE EN L SUR LE DEUXIÈME APPAREIL.

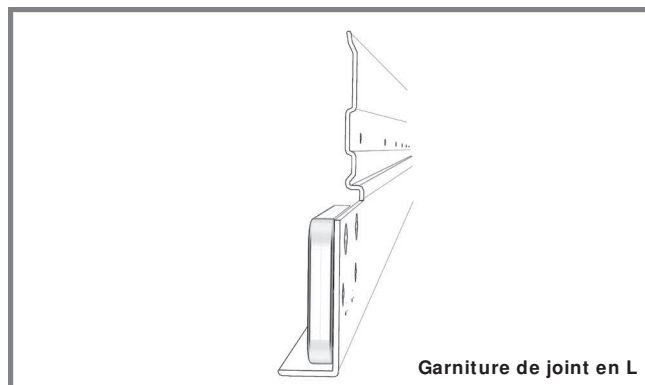
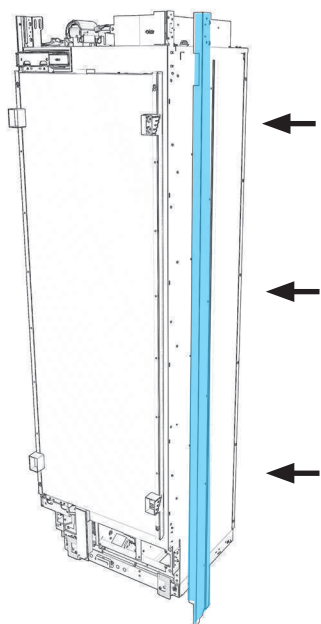

Garniture de joint en L

Tournevis cruciforme



2.7

SI TROIS APPAREILS SONT INSTALLÉS : INSTALLER LE JOINT DE GARNITURE EN CROCHET SUR LE TROISIÈME APPAREIL.

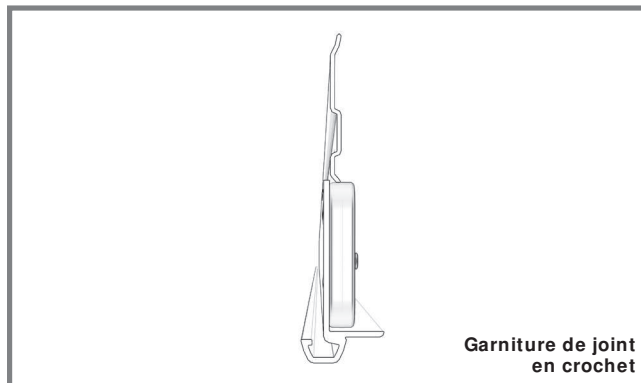
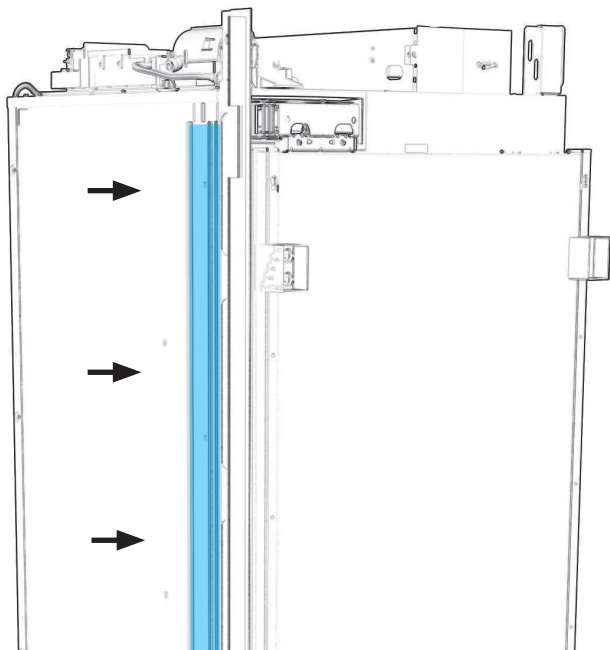

Tournevis cruciforme

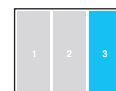

PRÉPARATION

DE LA BRIDE DE POSITIONNEMENT

3.1 PREMIER APPAREIL : GLISSER LA BRIDE DANS LA FENTE D'INSTALLATION.

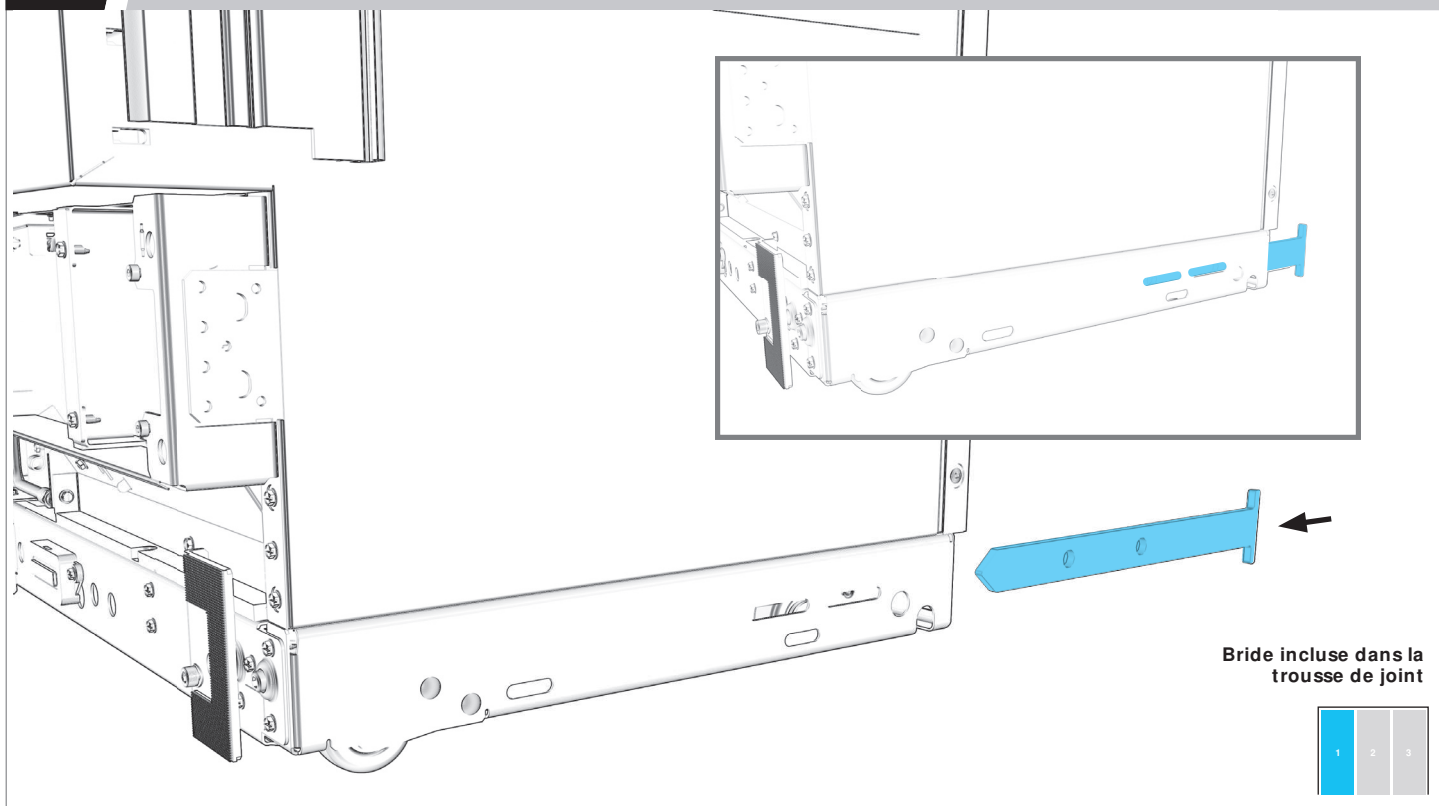

3.2 UTILISER UN TOURNEVIS POUR S'ASSURER QUE LES TROUS SONT ALIGNÉS.

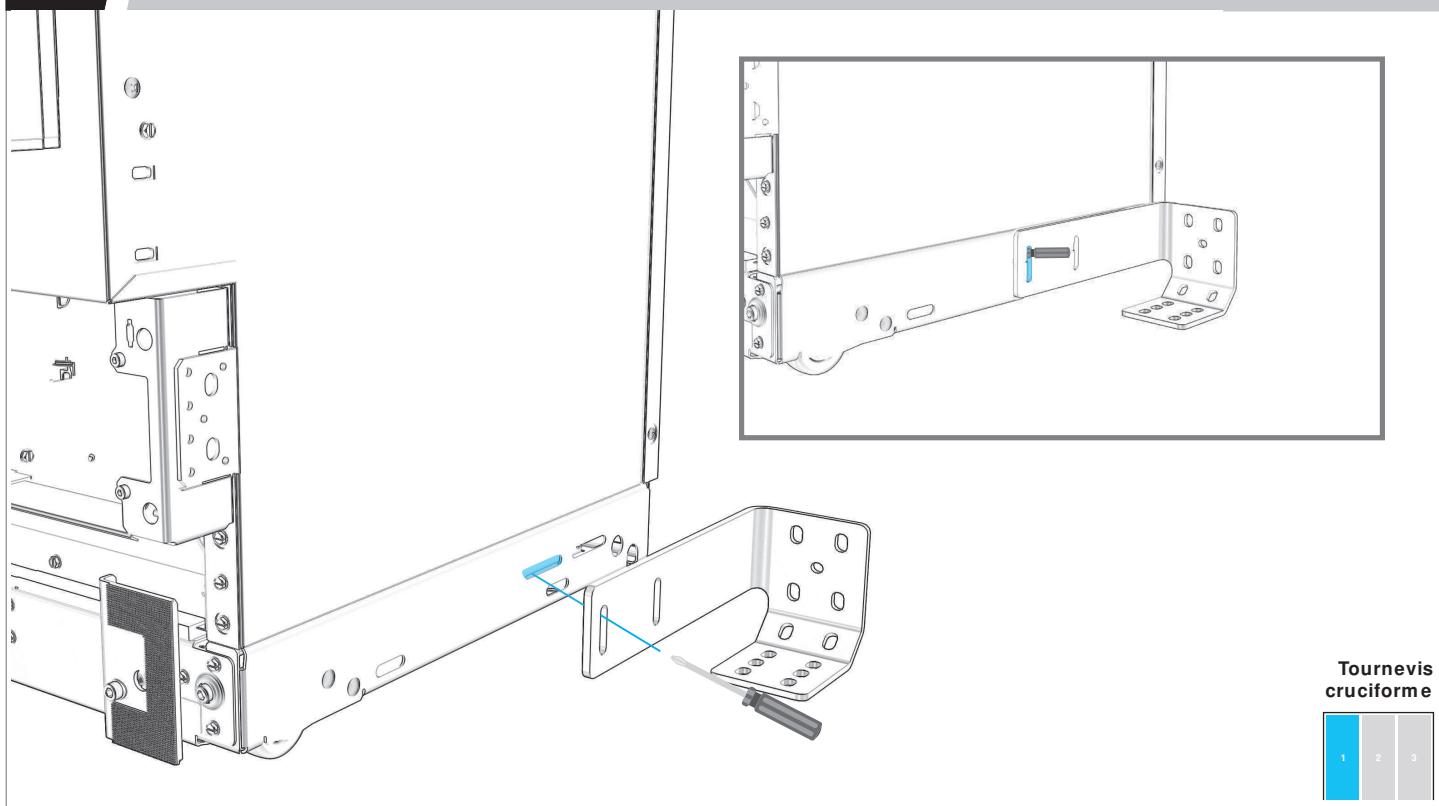

3

PRÉPARATION DE LA BRIDE DE POSITIONNEMENT

3.4

FIXER SANS SERRER LA BRIDE DE POSITIONNEMENT AU SUPPORT.

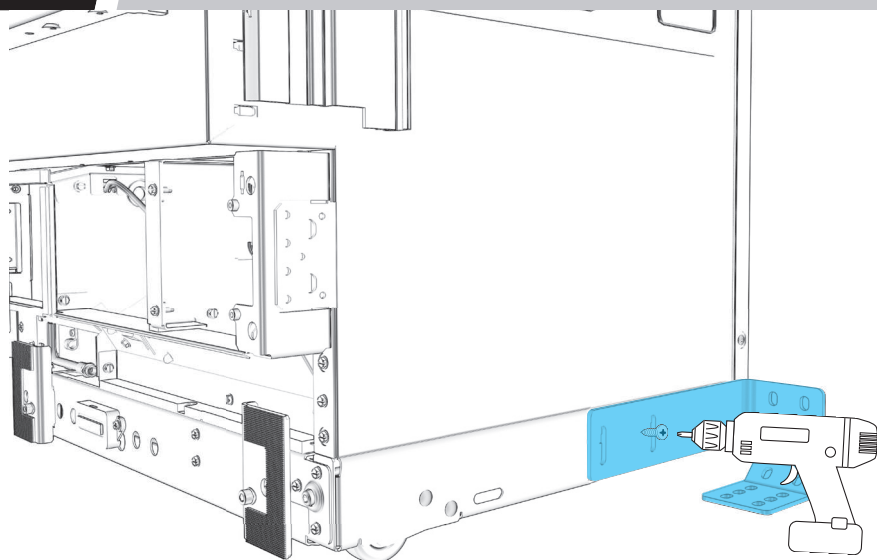

Douille M6



LA POSITION FINALE EST DÉTERMINÉE UNE FOIS LES APPAREILS ENTIÈREMENT SOULÉVÉS.

3.5

SI TROIS APPAREILS SONT INSTALLÉS : RÉPÉTER LES ÉTAPES 3.1 À 3.4 POUR LE DEUXIÈME APPAREIL.

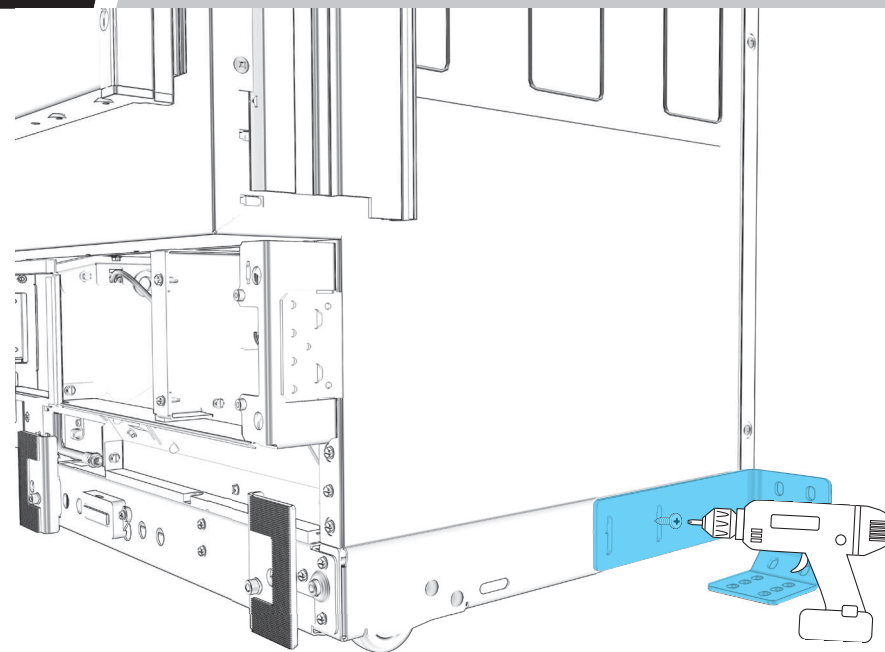

Douille M6

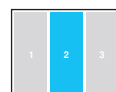

INSTALLATION DE LA BRIDE

B A D A S S

4

INSTALLATION DE LA BRIDE BADASS

4.1

MARQUE UNE LIGNE À LA LARGEUR DU PREMIER APPAREIL, À PARTIR DU CADRE DE GAUCHE.

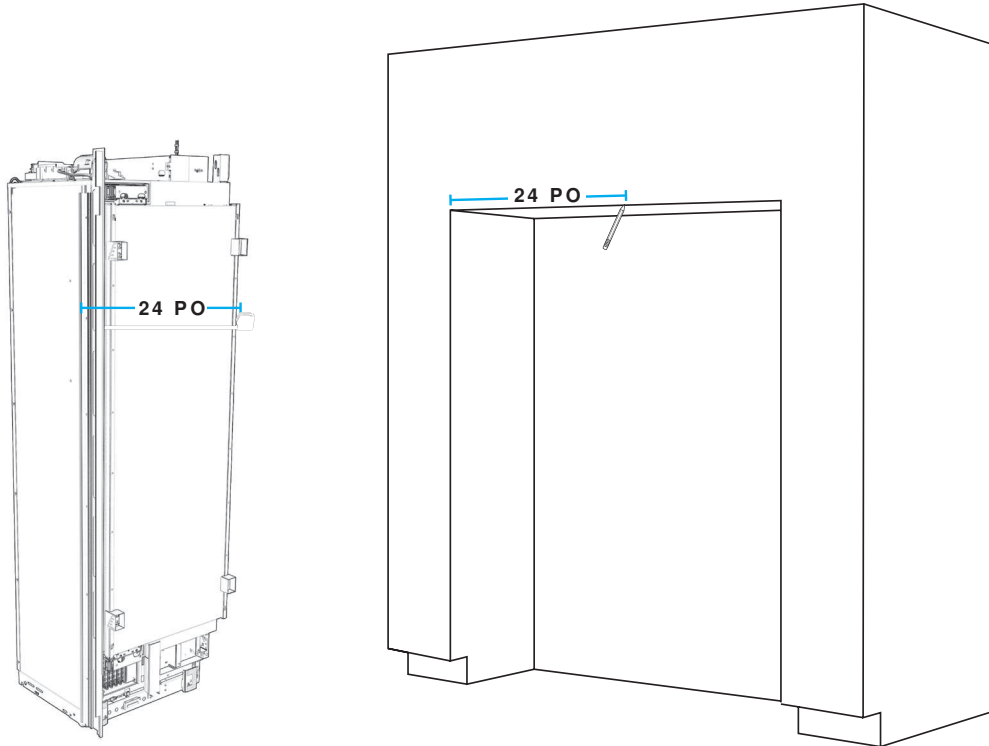

4.2

À L'AIDE D'UNE ÉQUERRE, TRACER UNE LIGNE PERPENDICULAIRE AU CADRE DE DEVANT.

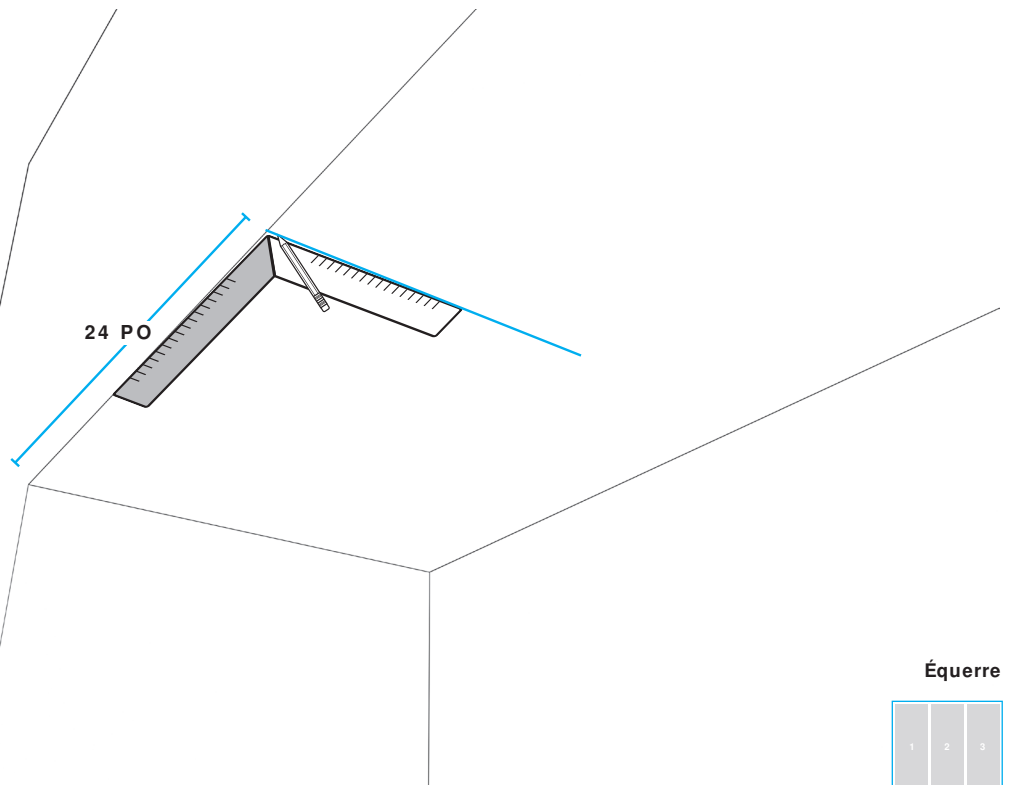

Équerre



4.3

ALIGNER LA FENTE CENTRALE DU GABARIT DE BRIDE AVEC LA LIGNE DE LARGEUR.

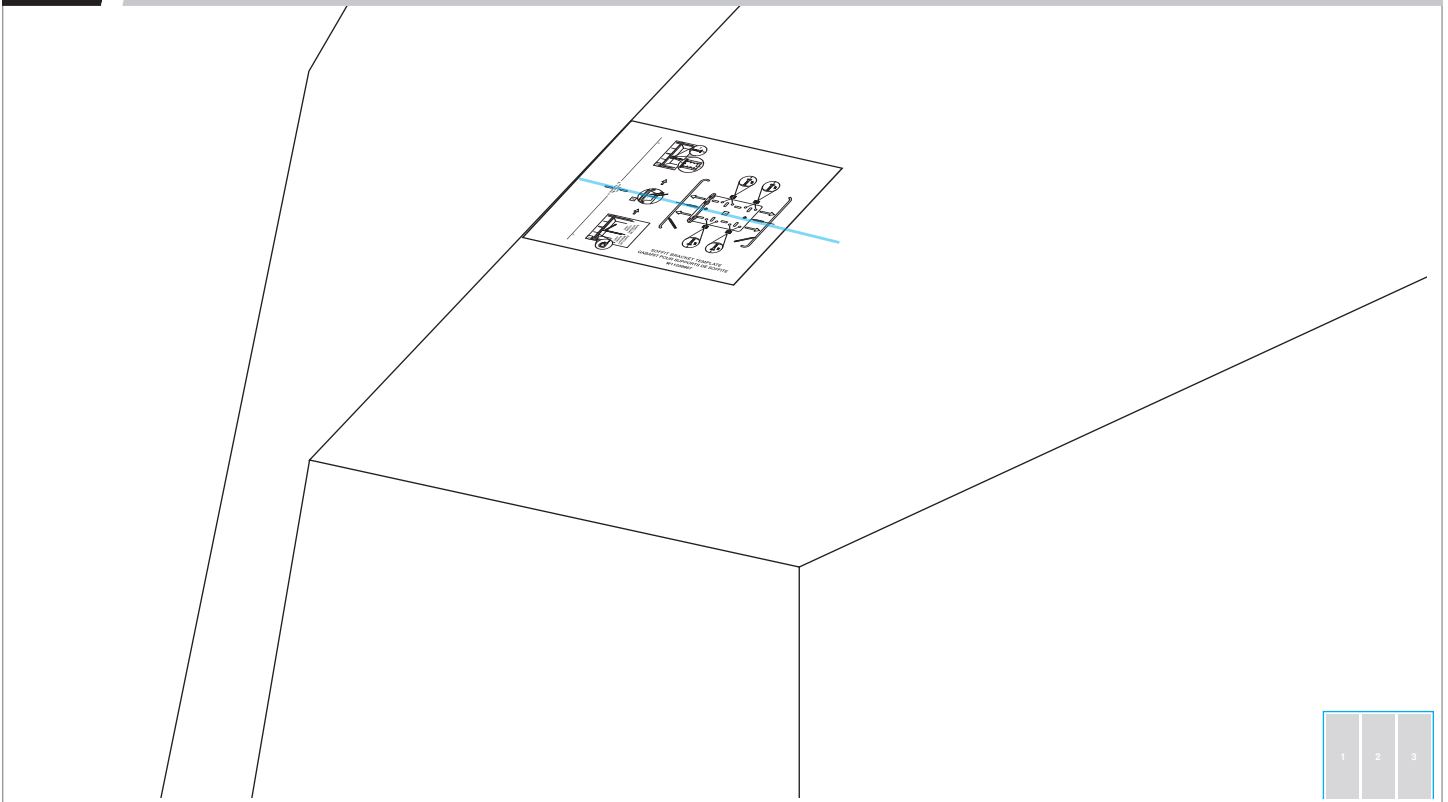

4.4

ALIGNER LA LIGNE DU TYPE DE PORTE DÉJÀ SÉLECTIONNÉ AVEC LE DEVANT DE L'ARMOIRE.

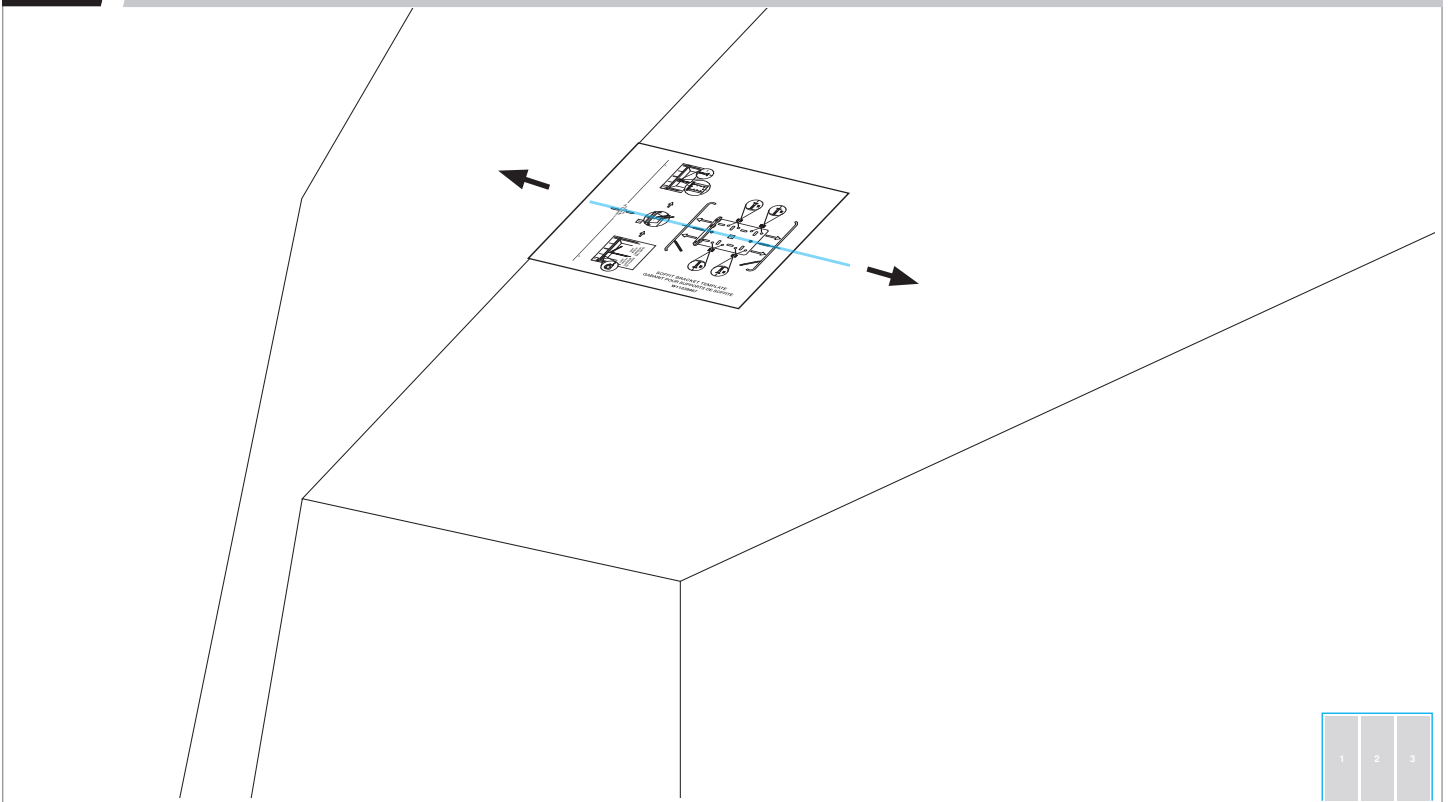

4

INSTALLATION DE LA BRIDE BADASS

4.5

MARQUER DEUX LIGNES.

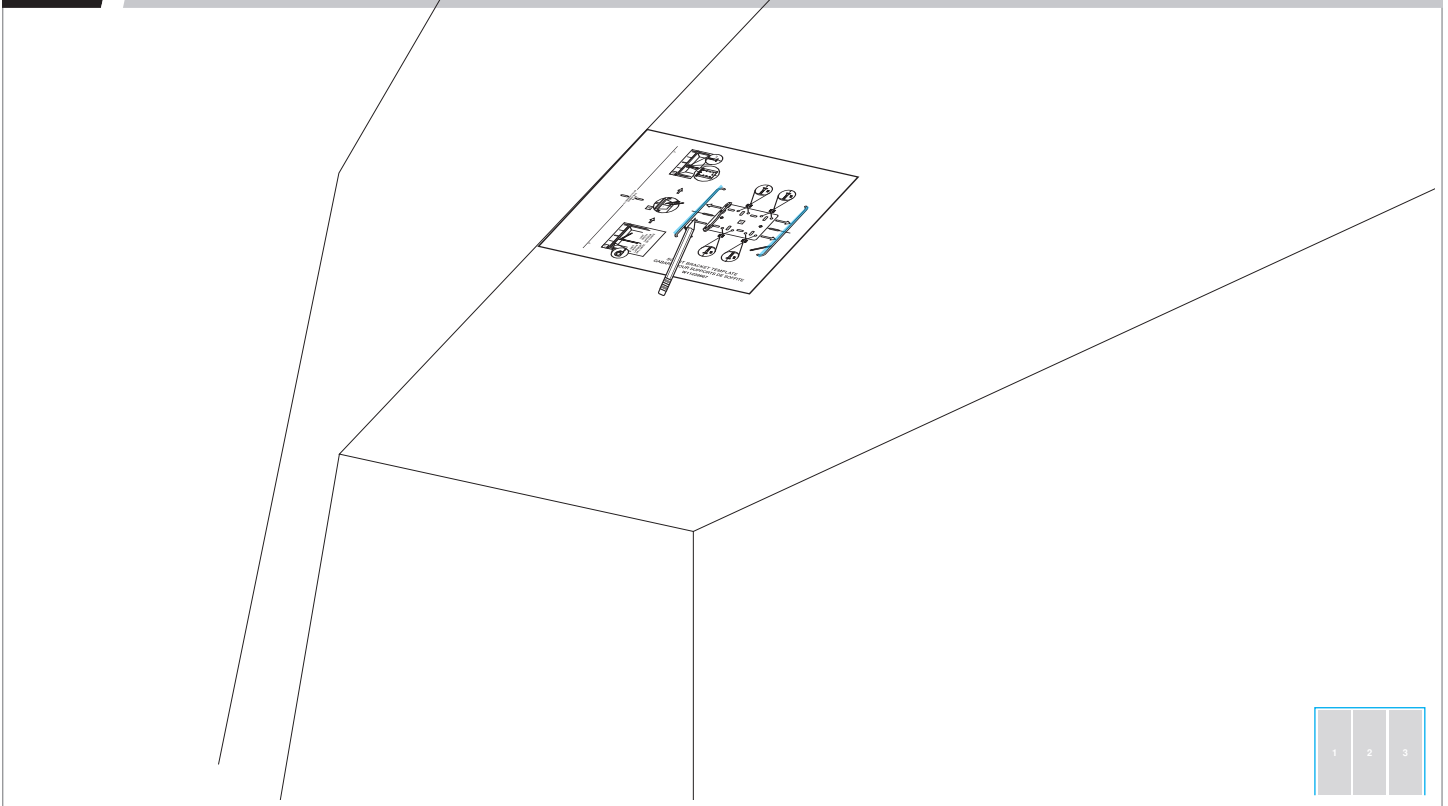

4.6

ALIGNER LA BRIDE.

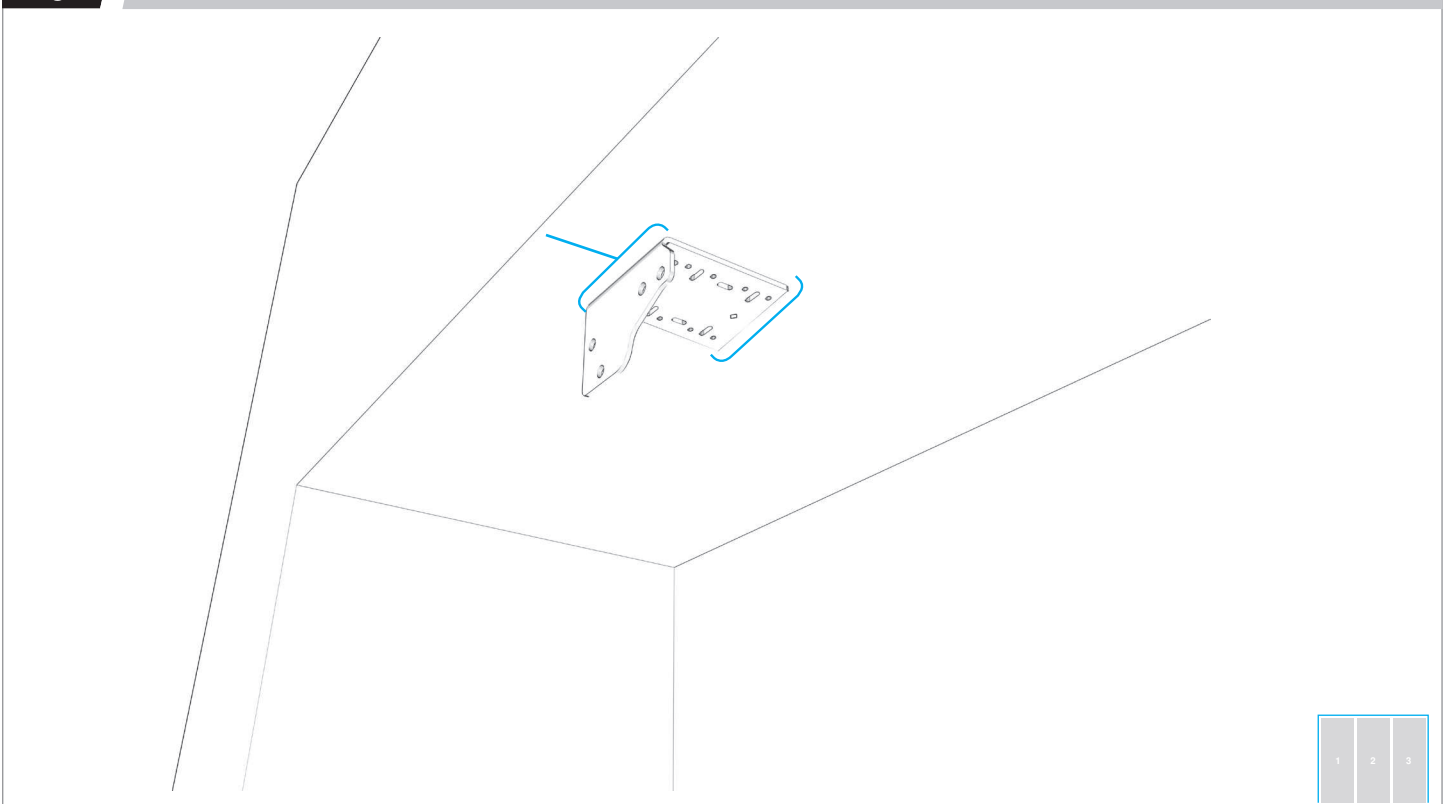

4.7

ALIGNER LES POINTS DES TROUS EN FORME DE DIAMANT ET LA LIGNE DE LARGEUR.

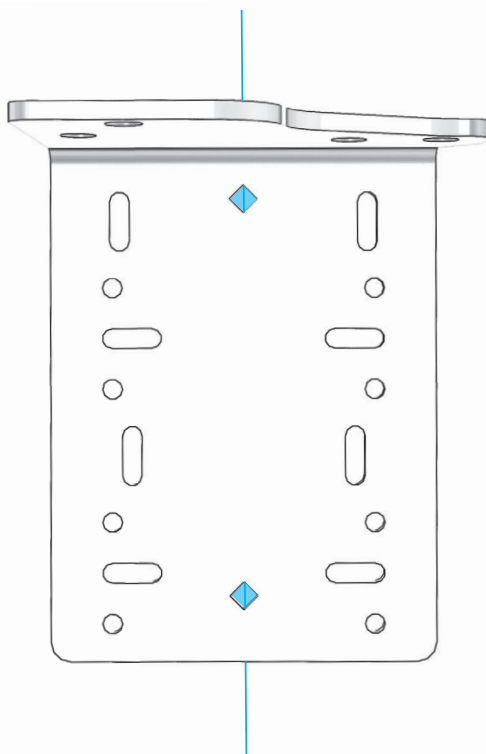

4.8

FIXER SANS SERRER LA BRIDE AU SOFFITE.

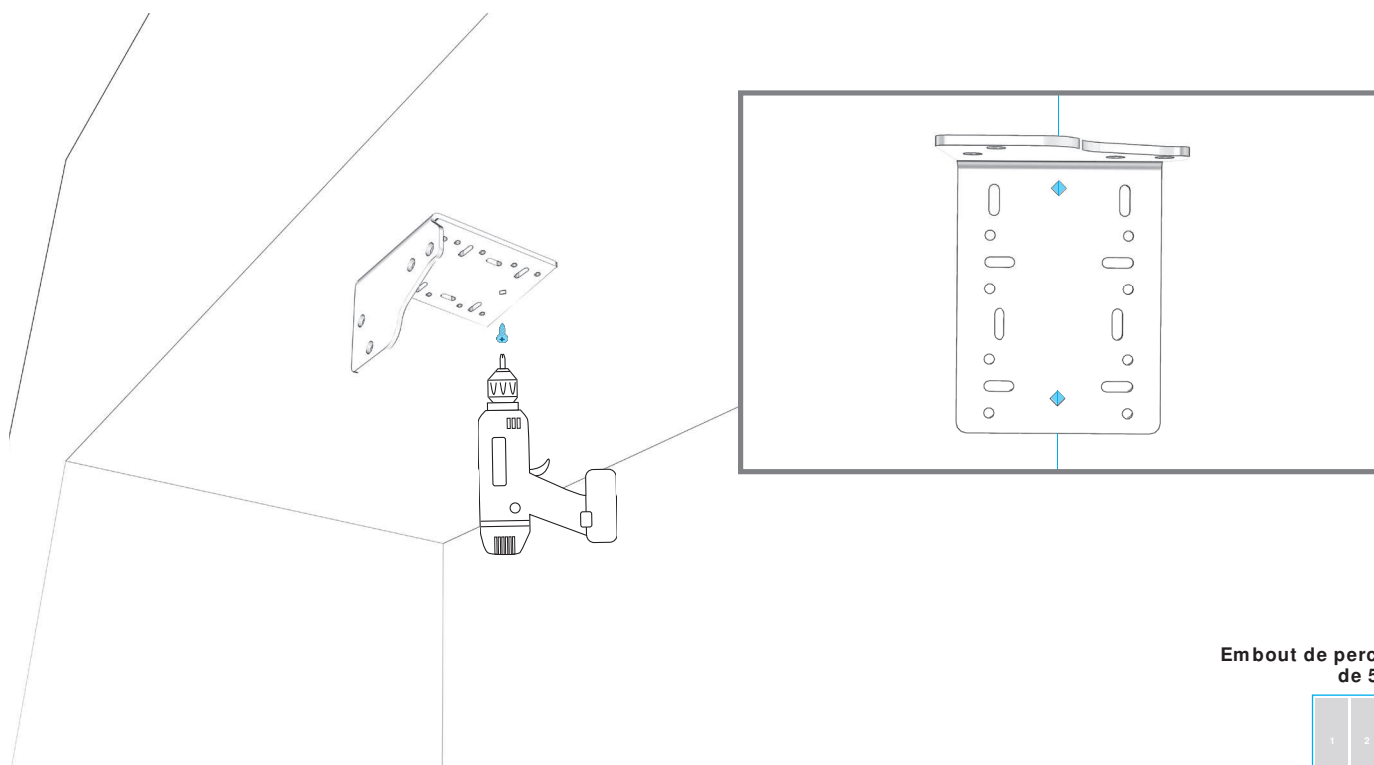

Embout de perceuse
de 5 mm



4

INSTALLATION DE LA BRIDE BADASS

4.9

ALIGNER DE NOUVEAU LES BORDS DE LA BRIDE AVEC LES LIGNES D'ALIGNEMENT.

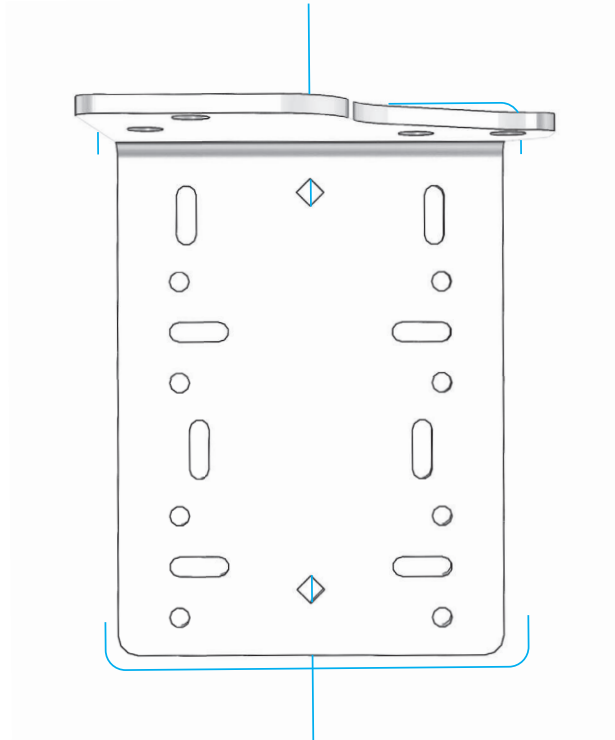

4.10

SERRER 8 VIS.

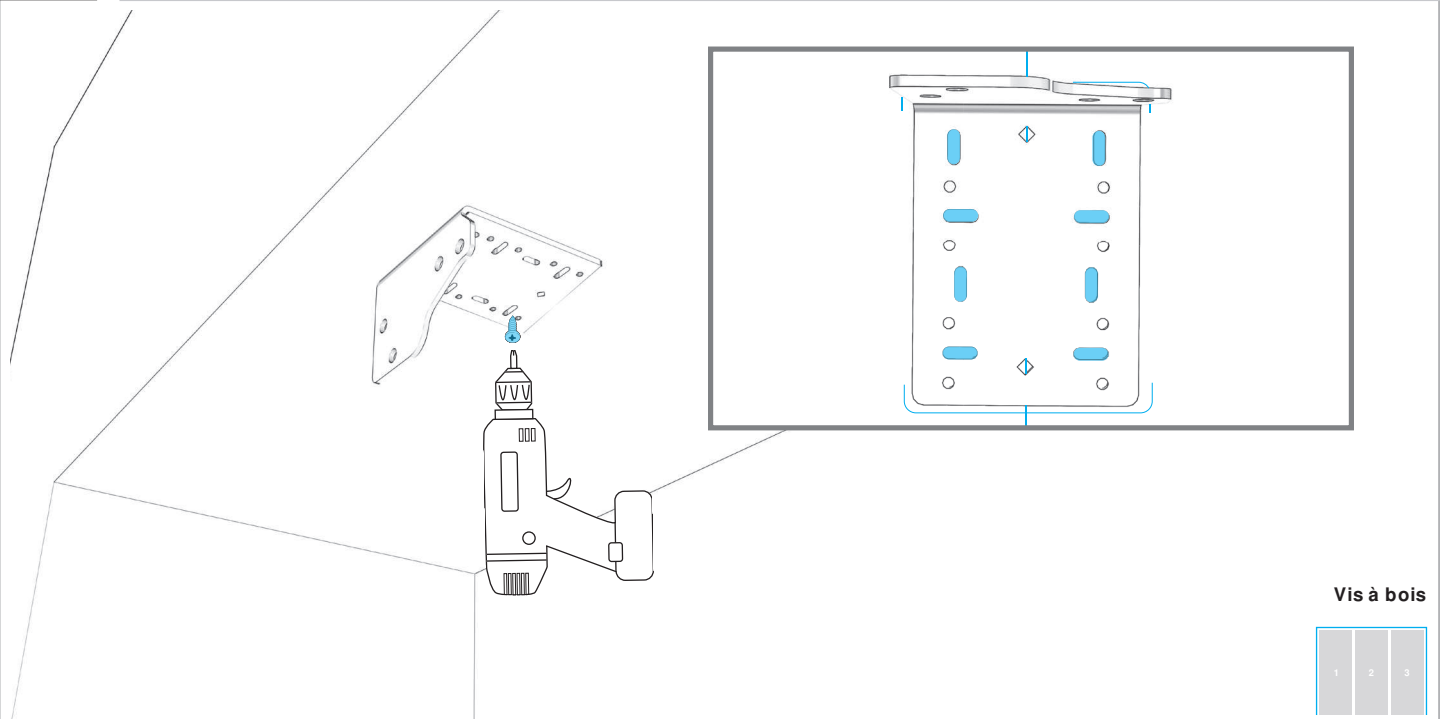

Vis à bois



UTILISER DES VIS À BOIS D'UNE LONGUEUR CONVENABLE

4.11

FIXER LA BRIDE À L'ARMOIRE EN UTILISANT LES TROUS ROUNDS.

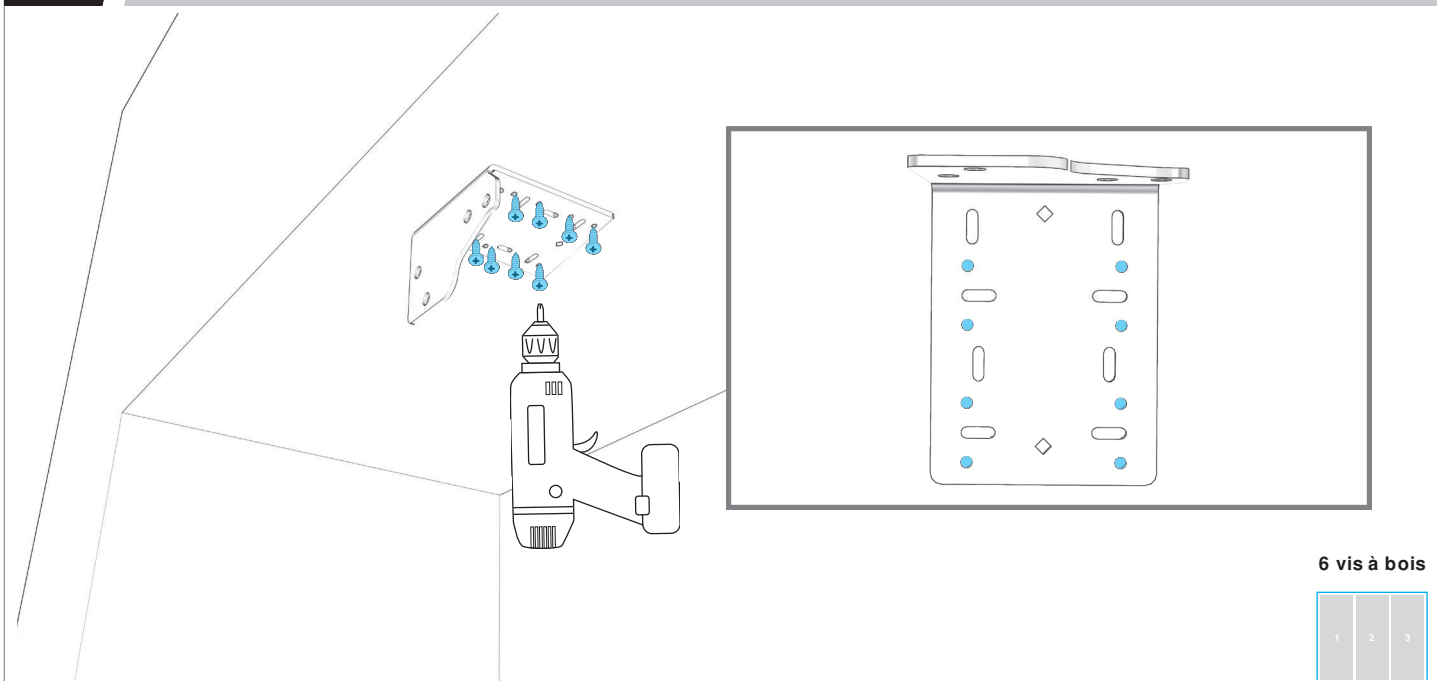

6 vis à bois



UN MINIMUM DE SIX VIS DOIT ÊTRE UTILISÉ POUR FIXER LES BRIDES À L'ARMOIRE. L'APPAREIL POURRAIT BASCULER SI LES BRIDES NE SONT PAS BIEN FIXÉES.

4.12

SI SEULEMENT DEUX APPAREILS SONT INSTALLÉS :

PASSER À LA SECTION 5

4

INSTALLATION DE LA BRIDE BADASS

4.13

SI TROIS APPAREILS SONT INSTALLÉS : AJOUTER LA LARGEUR DU DEUXIÈME APPAREIL À CELLE DU PREMIER.

LARGEUR DE L'OUVERTURE
42 po

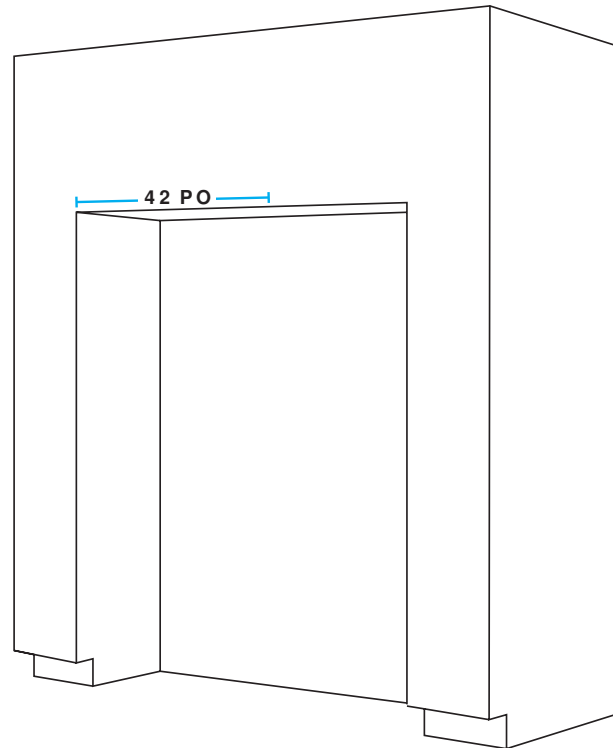
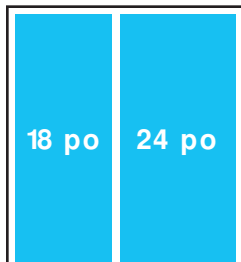

4.14

TRACER UNE LIGNE À LA LARGEUR MESURÉE.

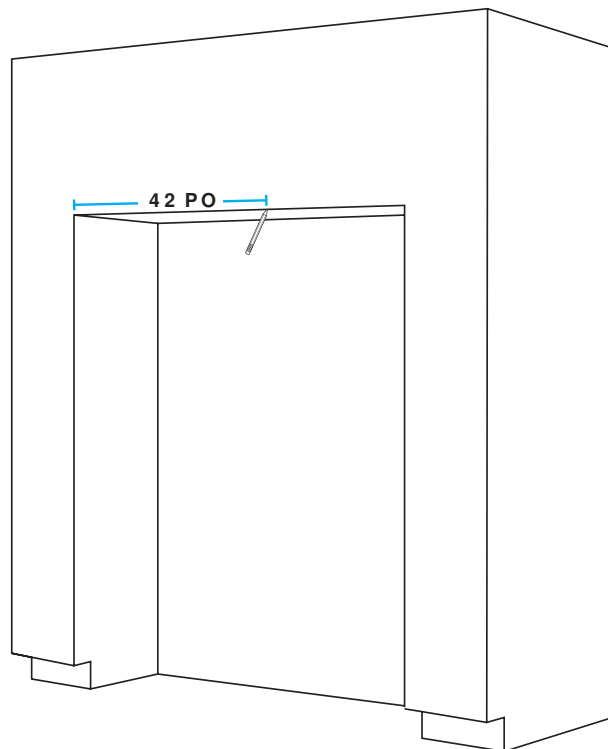

4.15

EFFECTUER LES ÉTAPES 4.2 À 4.11.

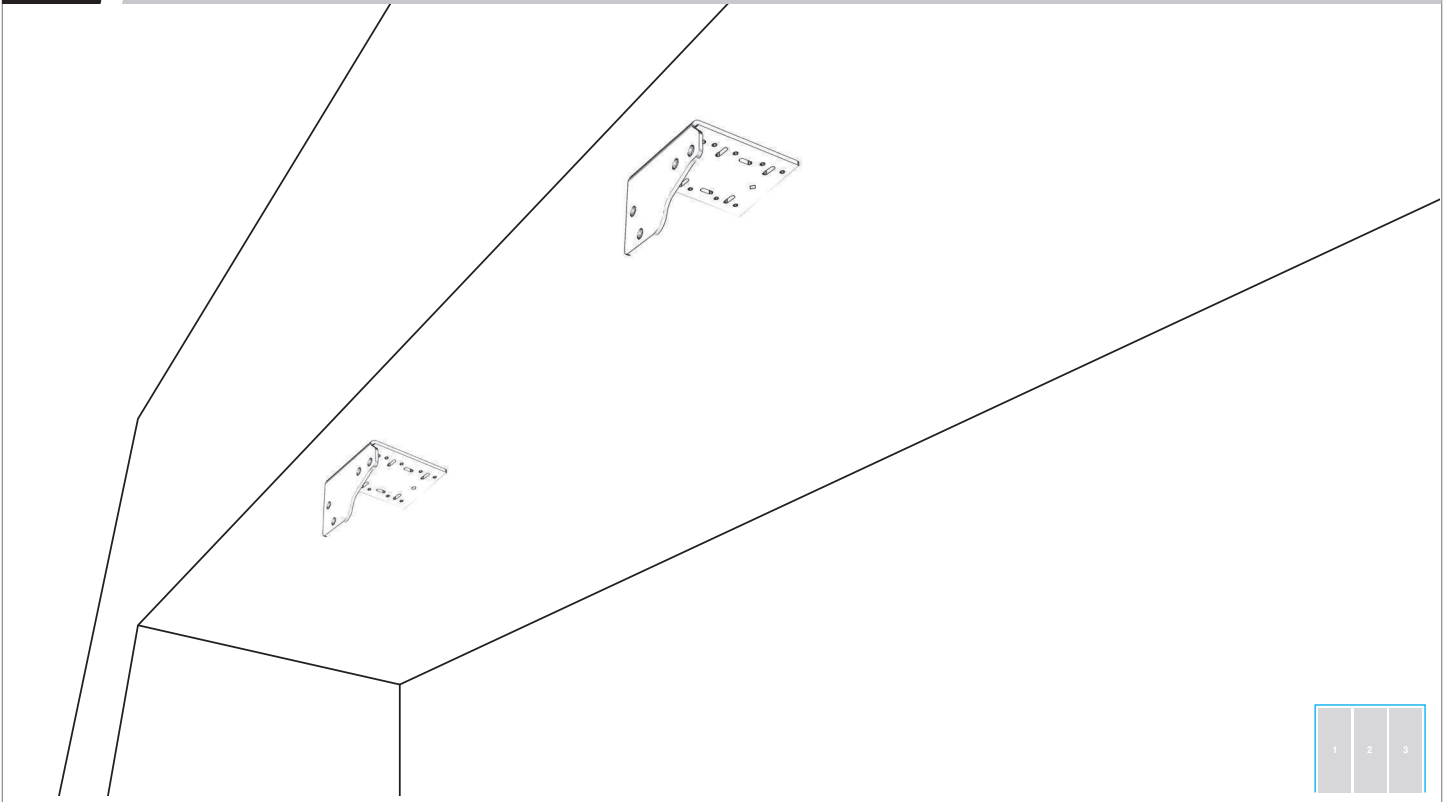

PRÉPARATION
DU MEUBLE

5.1

MESURER ET MARQUER UNE LIGNE POUR LE PANNEAU DE GAUCHE.

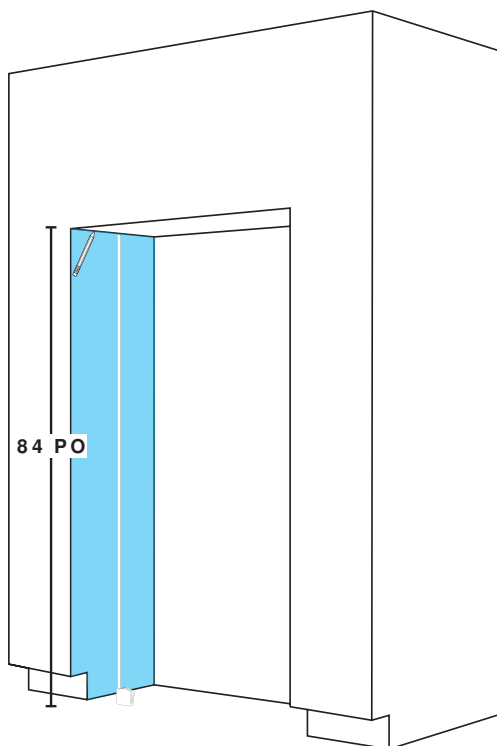

5.2

PLACER LE GABARIT SUR LE PANNEAU DE GAUCHE.

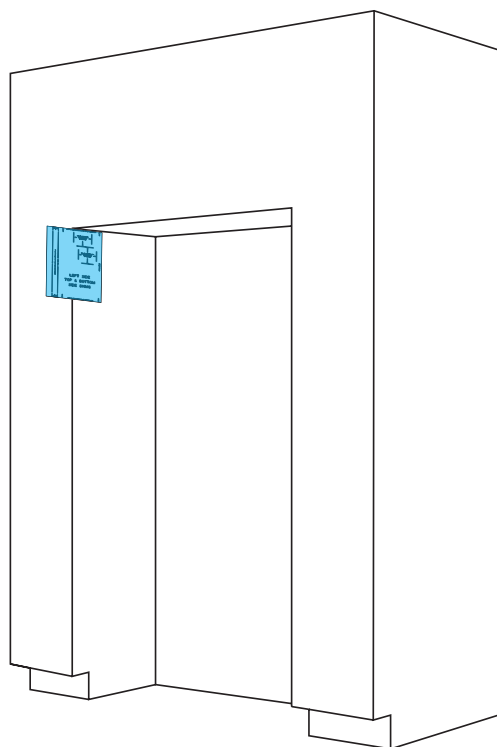

5

PRÉPARATION DU MEUBLE

5.3

ALIGNER LA LIGNE DE STYLE DE PORTE AVEC LE DEVANT DE L'ARMOIRE ET MARQUER LES LIGNES D'ALIGNEMENT.

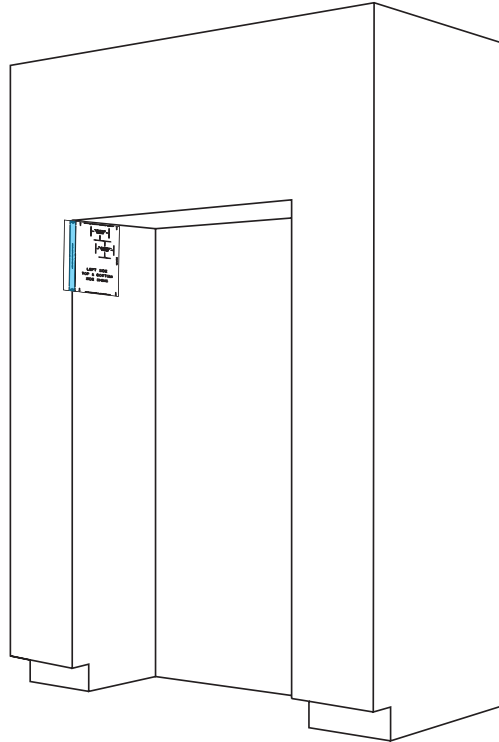

5.4

RÉPÉTER LES ÉTAPES 5.1 À 5.3 POUR LE PANNEAU DE DROITE.

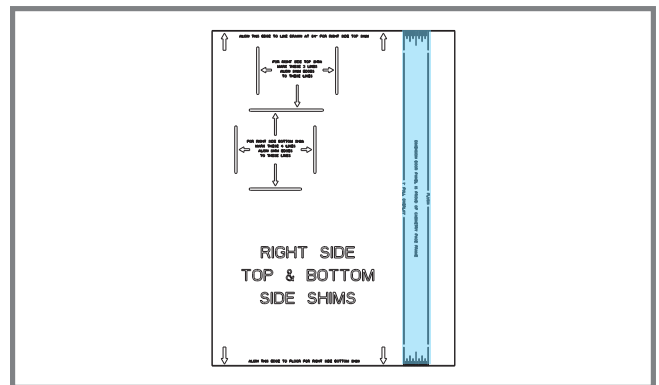
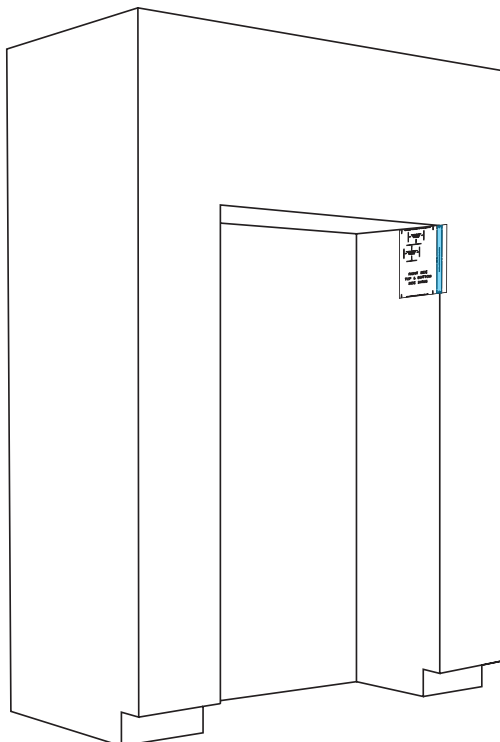

5.5

PLACER ET ALIGNER LE GABARIT SUR LA SECTION INFÉRIEURE DU PANNEAU DE GAUCHE, MARQUER LES LIGNES D'ALIGNEMENTS DE CALES.

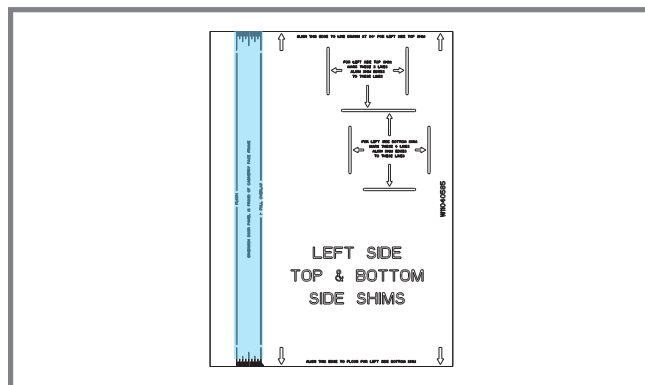
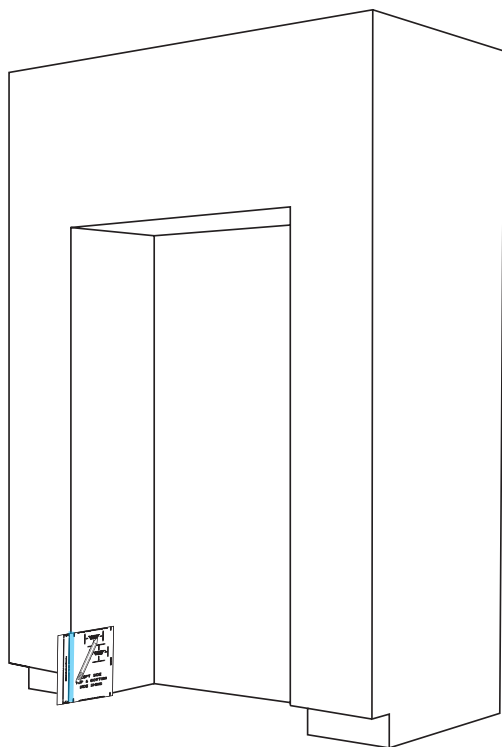

5.6

RÉPÉTER L'ÉTAPE 5.5 POUR LE PANNEAU DE DROITE.

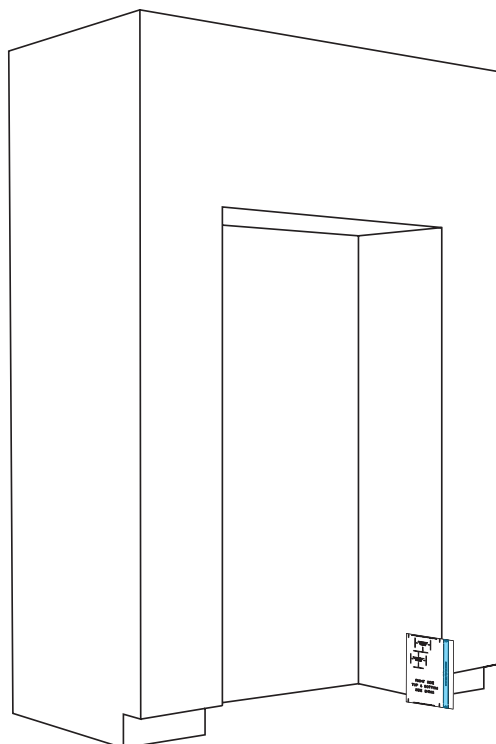

5

PRÉPARATION DU MEUBLE

5.7

SÉPARER LES CALES ROTTER EN RESPECTANT LES LONGUEURS.

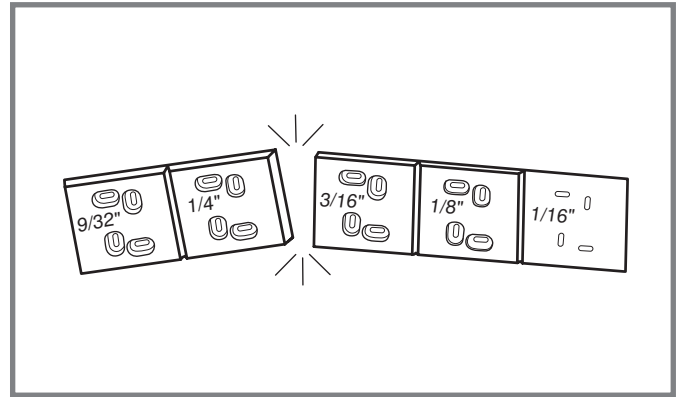
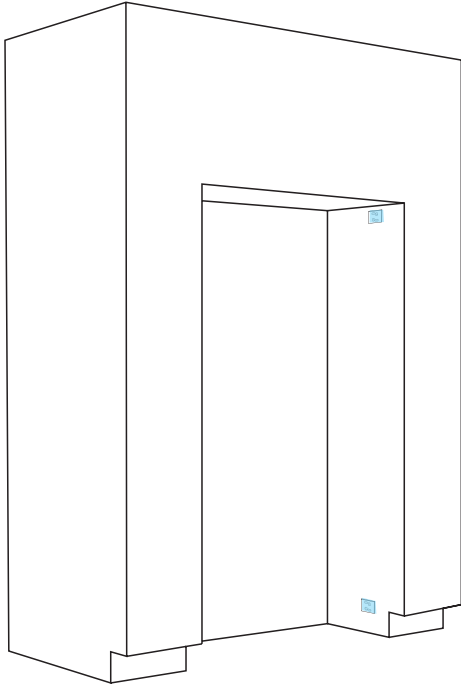

5.8

AJOUTER DES CALES AU BESOIN.

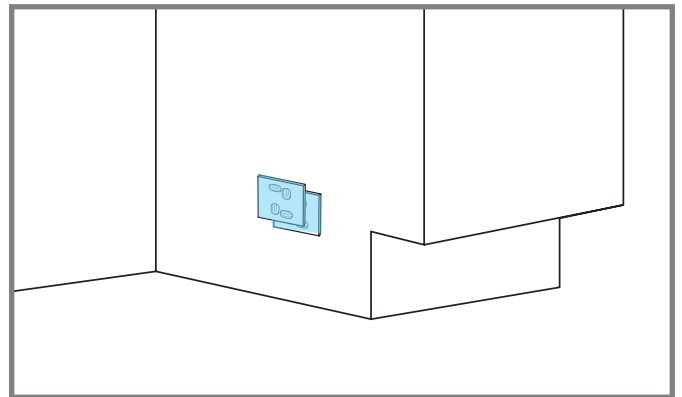
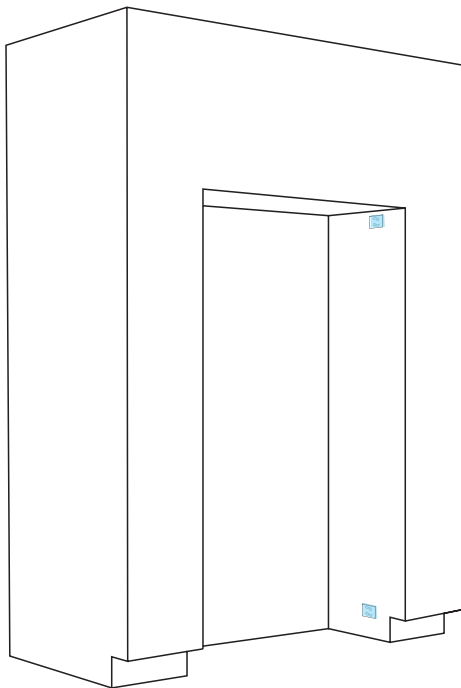

5.9

FIXER LES CALES AUX PANNEAUX LATÉRAUX DEUX VIS REQUISES .

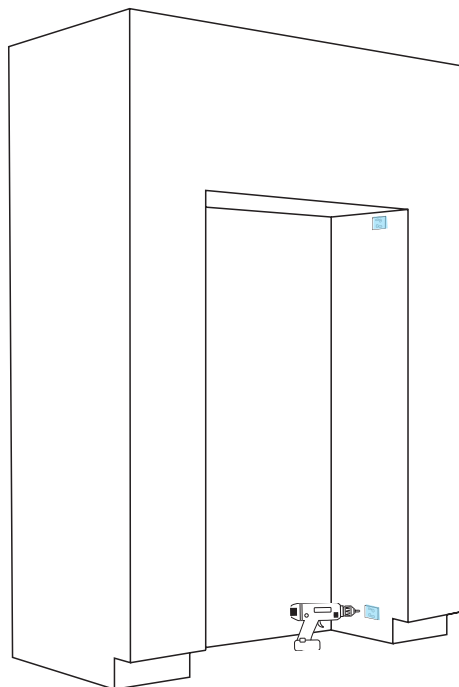

Vis à bois



UTILISER DES VIS À BOIS D'UNE LONGUEUR CONVENABLE

5.10

UTILISER DU RUBAN ADHÉSIF POUR FIXER LE TUYAU D'EAU AU PLANCHER.

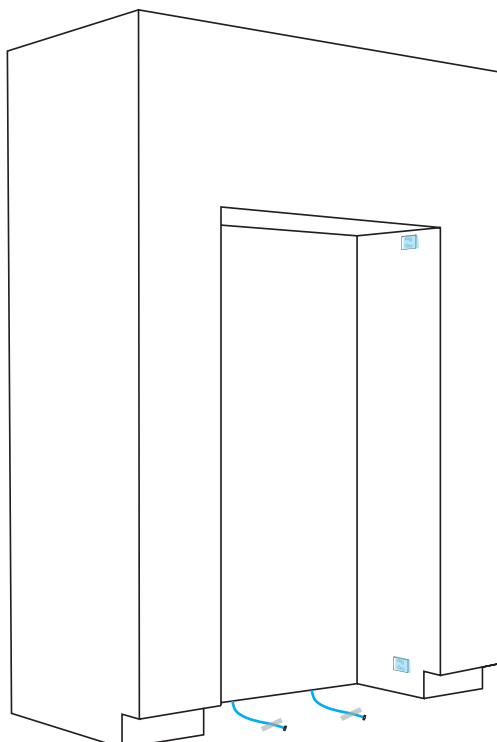

INSTALLATION DU
P R E M I E R
APPAREIL

6.1

ÉTEINDRE L'ALIMENTATION.

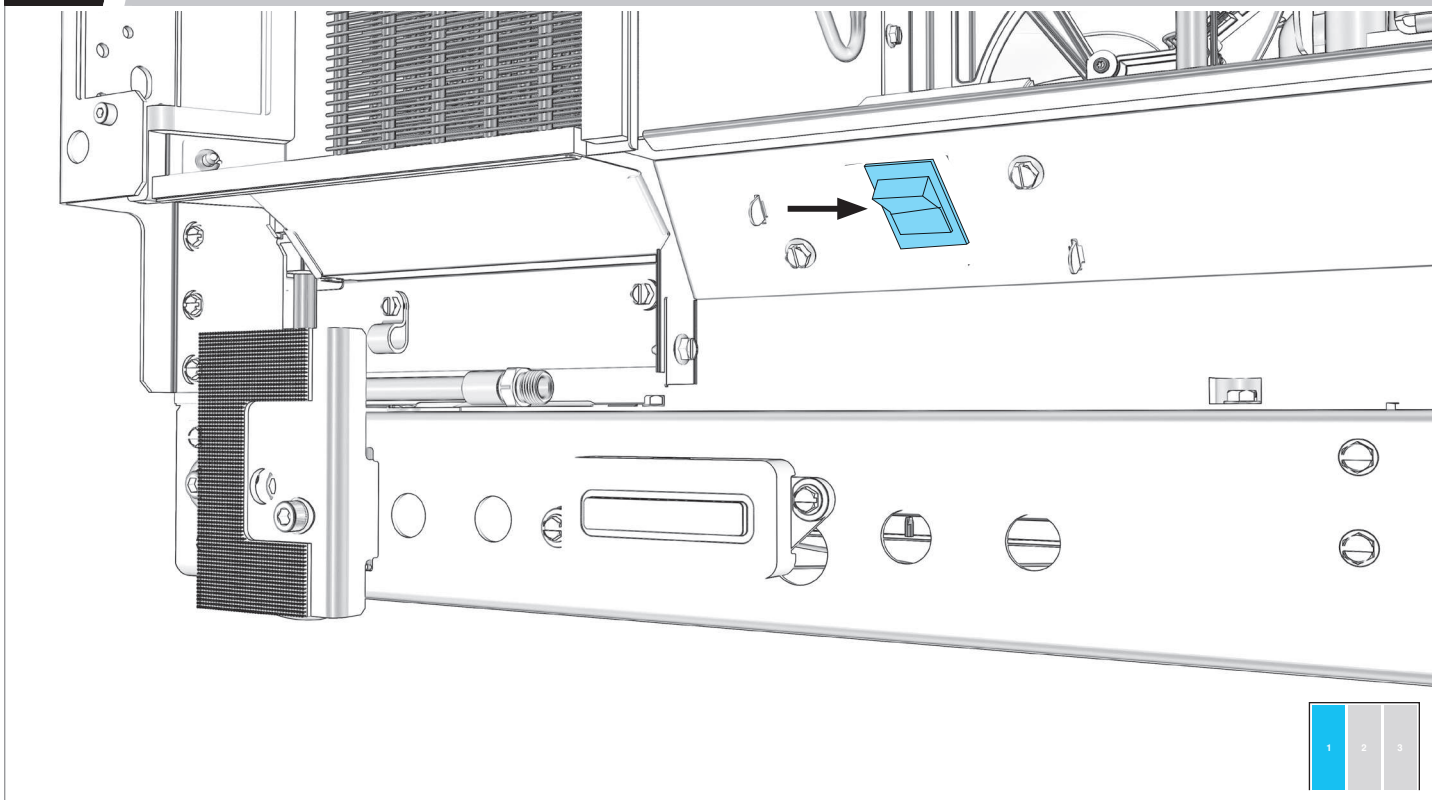

AVANT DE BRANCHER L'APPAREIL, LIRE LES AVERTISSEMENTS.

⚠ AVERTISSEMENT



Risque de choc électrique

Brancher sur une prise à 3 alvéoles reliée à la terre.

Ne pas enlever la broche de liaison à la terre.

Ne pas utiliser un adaptateur.

Ne pas utiliser un câble de rallonge.

Le non-respect de ces instructions peut causer un décès, un incendie ou un choc électrique.

6

INSTALLATION DU PREMIER APPAREIL

6.2

BRANCHER À UNE PRISE À TROIS ALVÉOLES RELIÉE À LA TERRE.

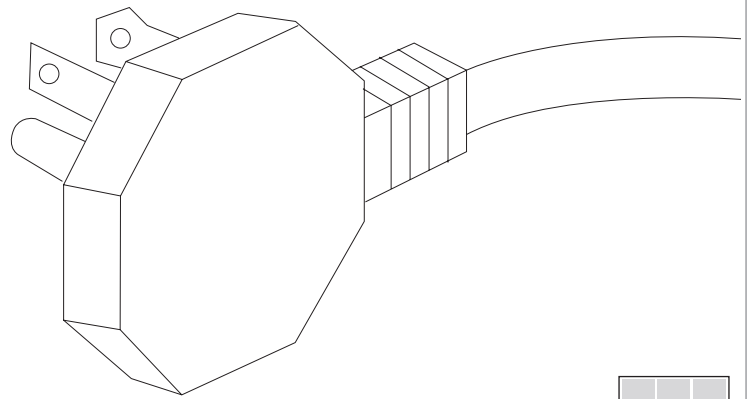
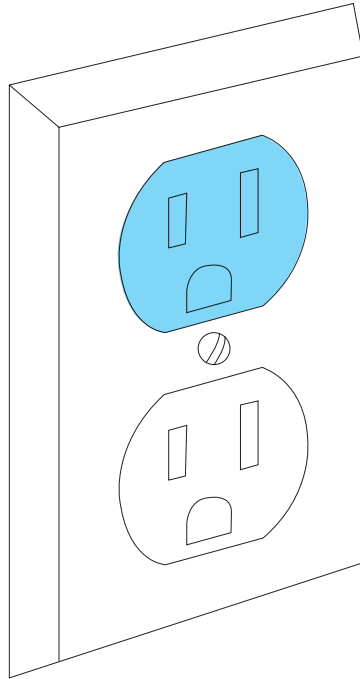

AVANT DE DÉPLACER L'APPAREIL, LIRE LES AVERTISSEMENTS.

⚠ AVERTISSEMENT

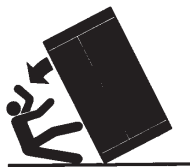

Risque de basculement

Le réfrigérateur est lourd au sommet et bascule facilement lorsqu'il n'est pas complètement installé.

Garder les portes fermées avec un ruban adhésif jusqu'à l'installation complète du réfrigérateur.

Utiliser deux ou plus de personnes pour déplacer et installer le réfrigérateur.

Le non-respect de ces instructions peut causer un décès ou une blessure grave.

Déplacement de votre réfrigérateur :

Votre réfrigérateur est lourd. Lors du déplacement de votre réfrigérateur pour le nettoyage ou un entretien ou réparation, veiller à recouvrir le plancher avec du carton ou un panneau de fibres dures pour éviter qu'il ne subisse tout dommage. Toujours tirer le réfrigérateur tout droit lors de son déplacement. Ne pas incliner le réfrigérateur d'un côté ou de l'autre ni le "faire marcher" en essayant de le déplacer car le plancher pourrait être endommagé.

Importants renseignements à savoir au sujet des tablettes et des couvercles en verre :

Ne pas nettoyer les tablettes ou couvercles en verre avec de l'eau tiède quand ils sont froids. Les tablettes et les couvercles peuvent se briser s'ils sont exposés à des changements soudains de température ou à un impact tel que coup brusque. Le verre trempé est conçu pour éclater en d'innombrables pièces minuscules. Ceci est normal. Les tablettes et les couvercles en verre sont lourds. Les saisir à deux mains lors de leur dépose afin d'éviter de les faire tomber.

6.3 PLACER L'APPAREIL DANS L'OUVERTURE.

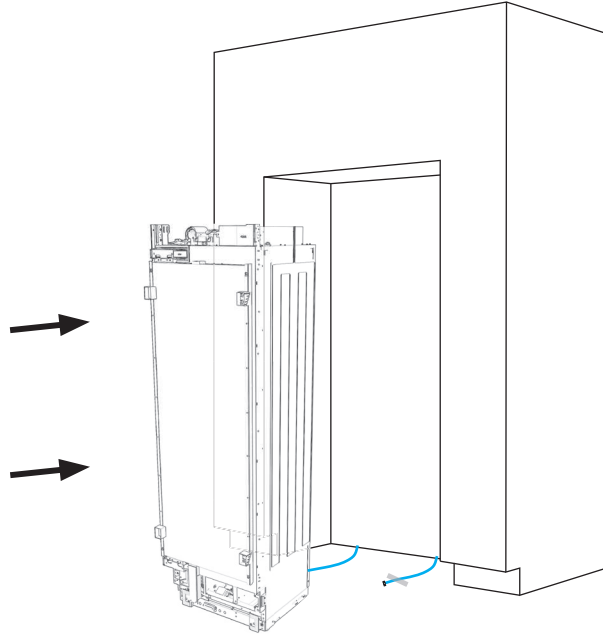

NE PAS ENDOMMAGER LE TUYAU D'EAU.

6.4 UTILISER UN GABARIT DE PROFONDEUR SELON LE STYLE DE PORTE .

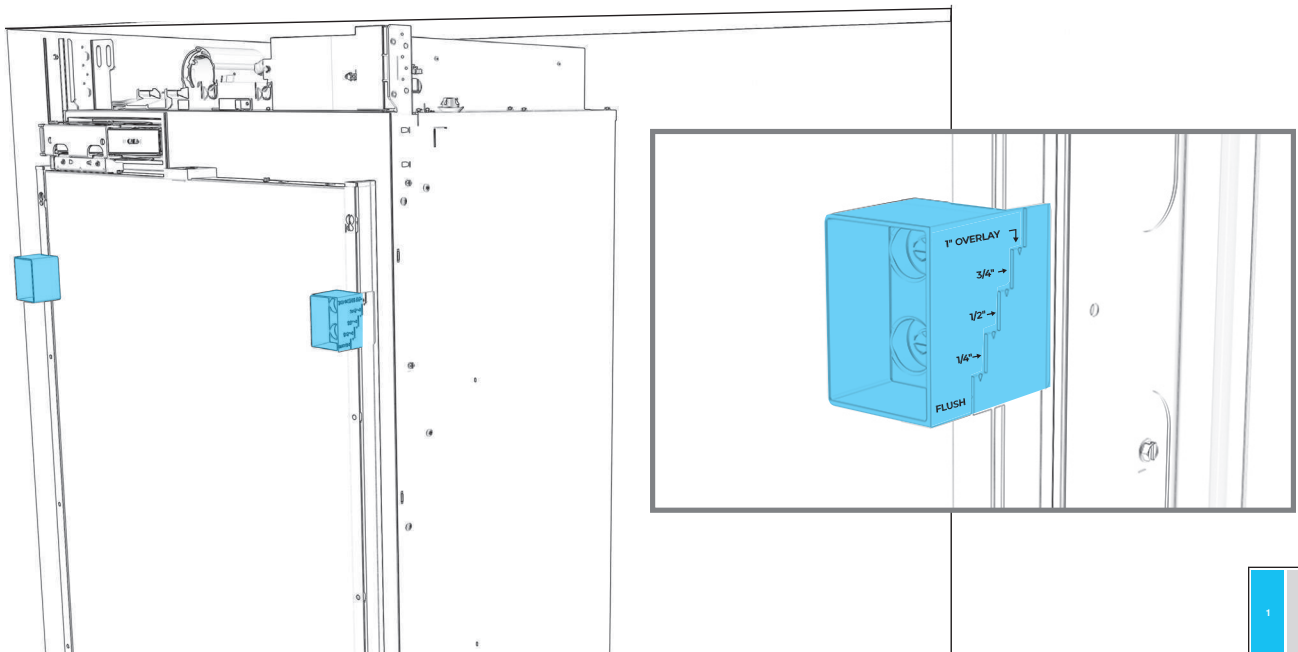

6

INSTALLATION DU PREMIER APPAREIL

6.5

FAIRE SORTIR LES ROULETTES UNE À UNE.

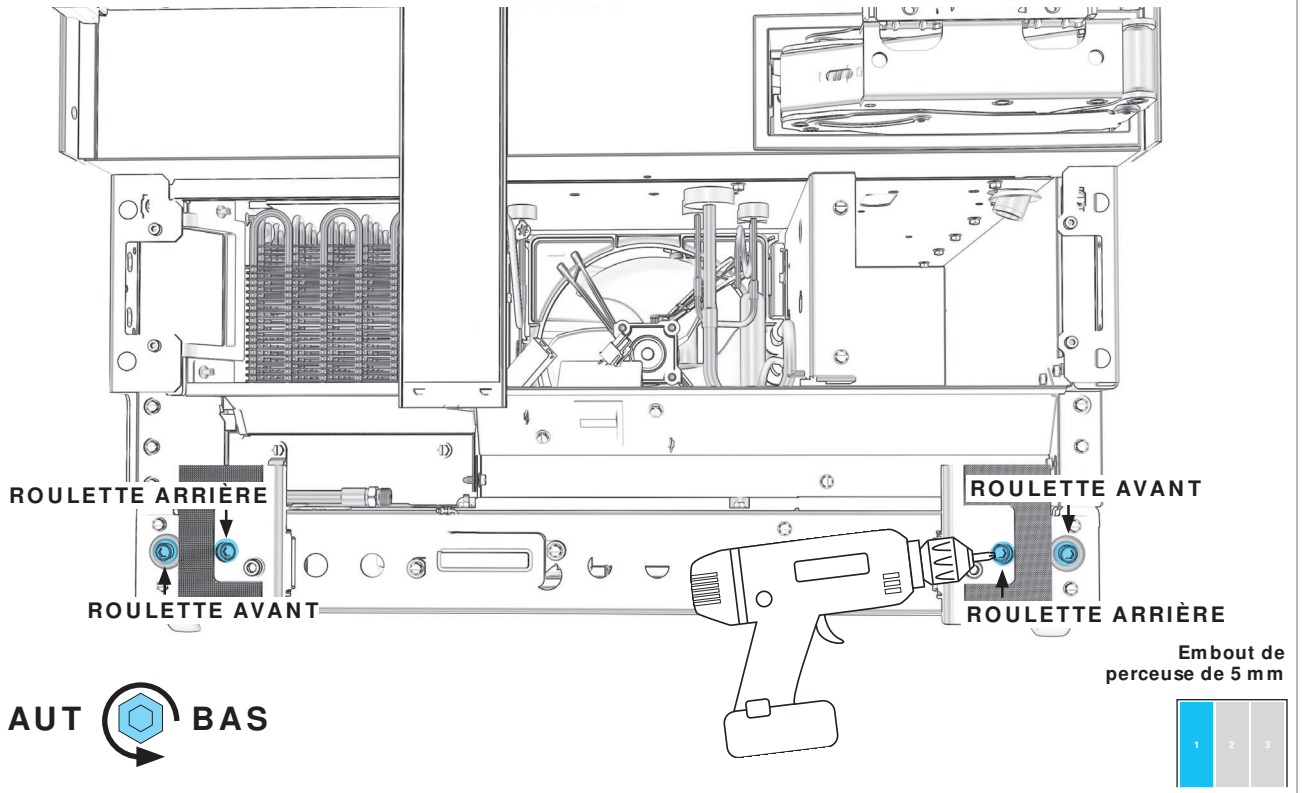

6.6

S'ASSURER QUE LA BRIDE D'INSTALLATION EST ALIGNÉE AVEC LA LIGNE DE 84 PO.

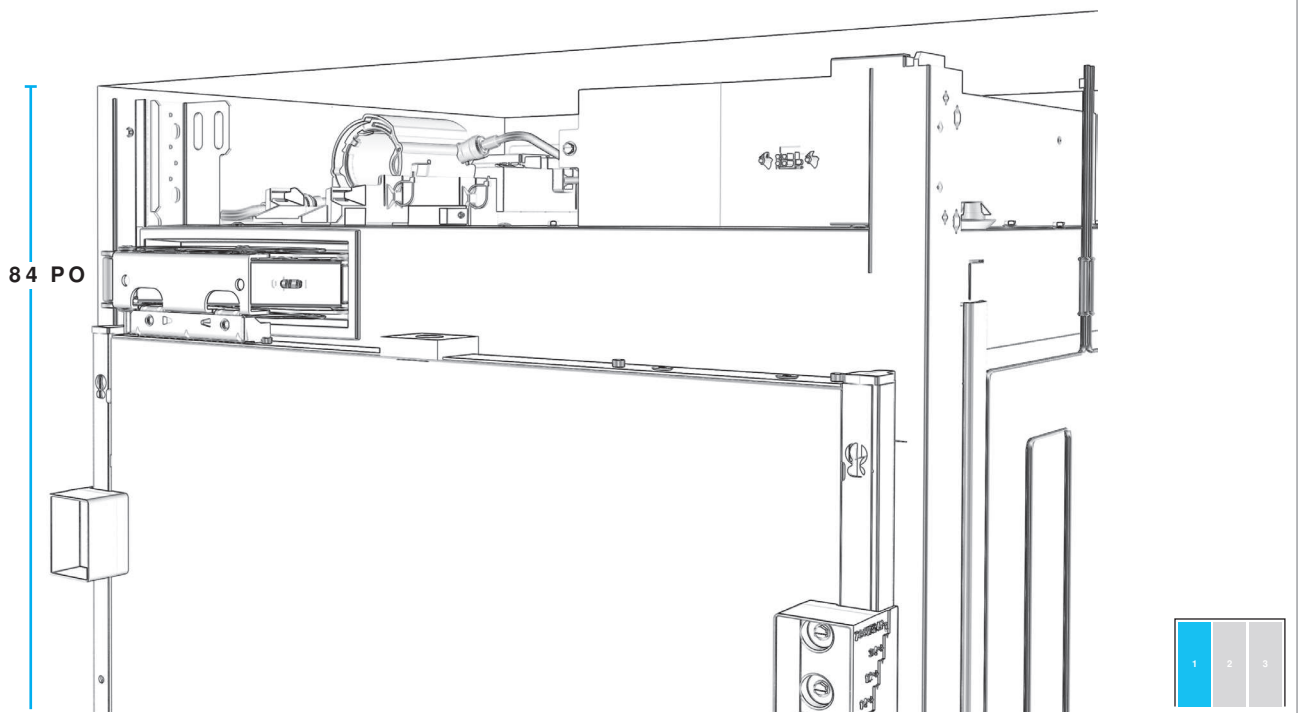

6.7

VÉRIFIER QUE LES GABARITS DE PROFONDEUR INDICENT LA MÊME PROFONDEUR.

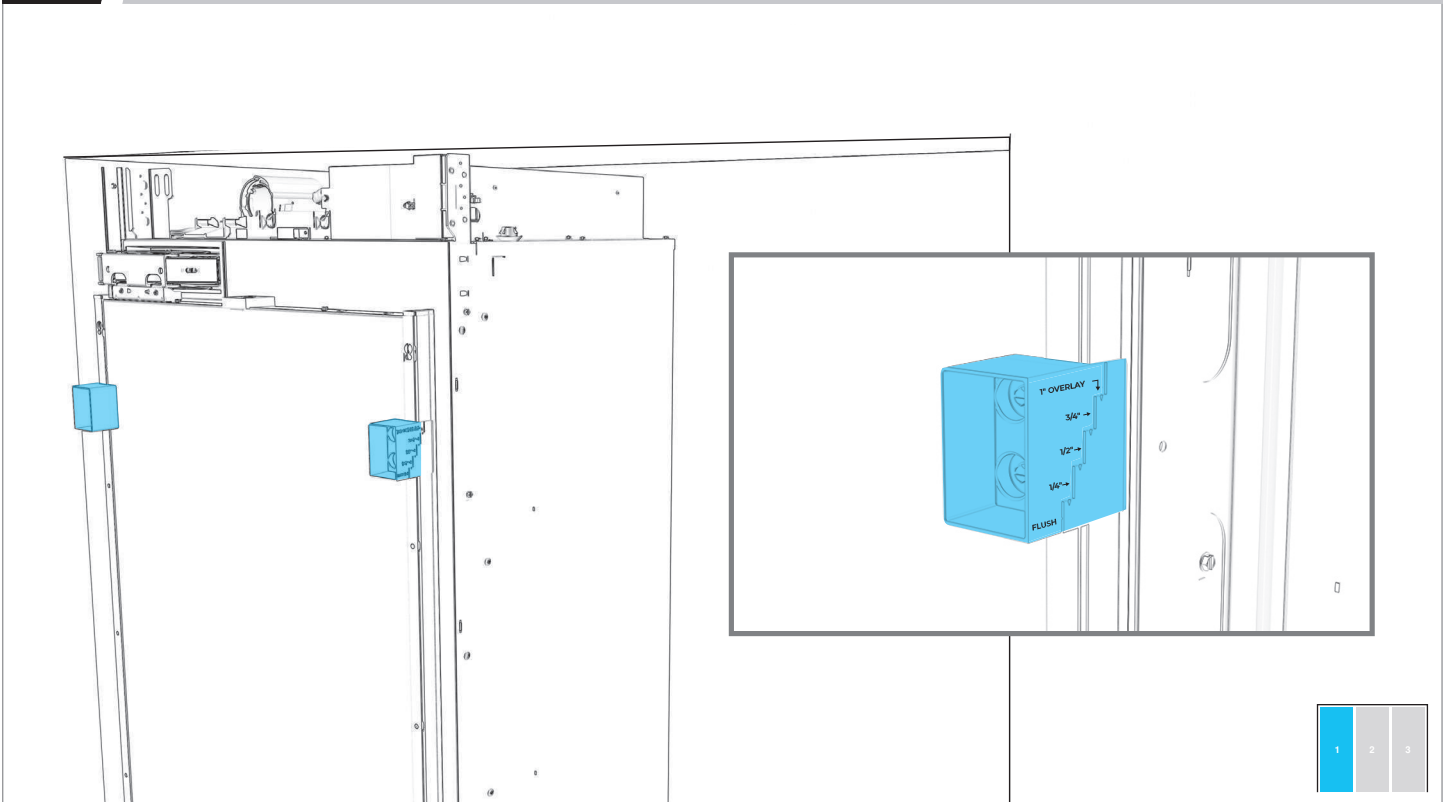

6.8

AJUSTER LES ROULETTES JUSQU'À CE QUE LES GABARITS DE PROFONDEUR SOIENT IDENTIQUES.

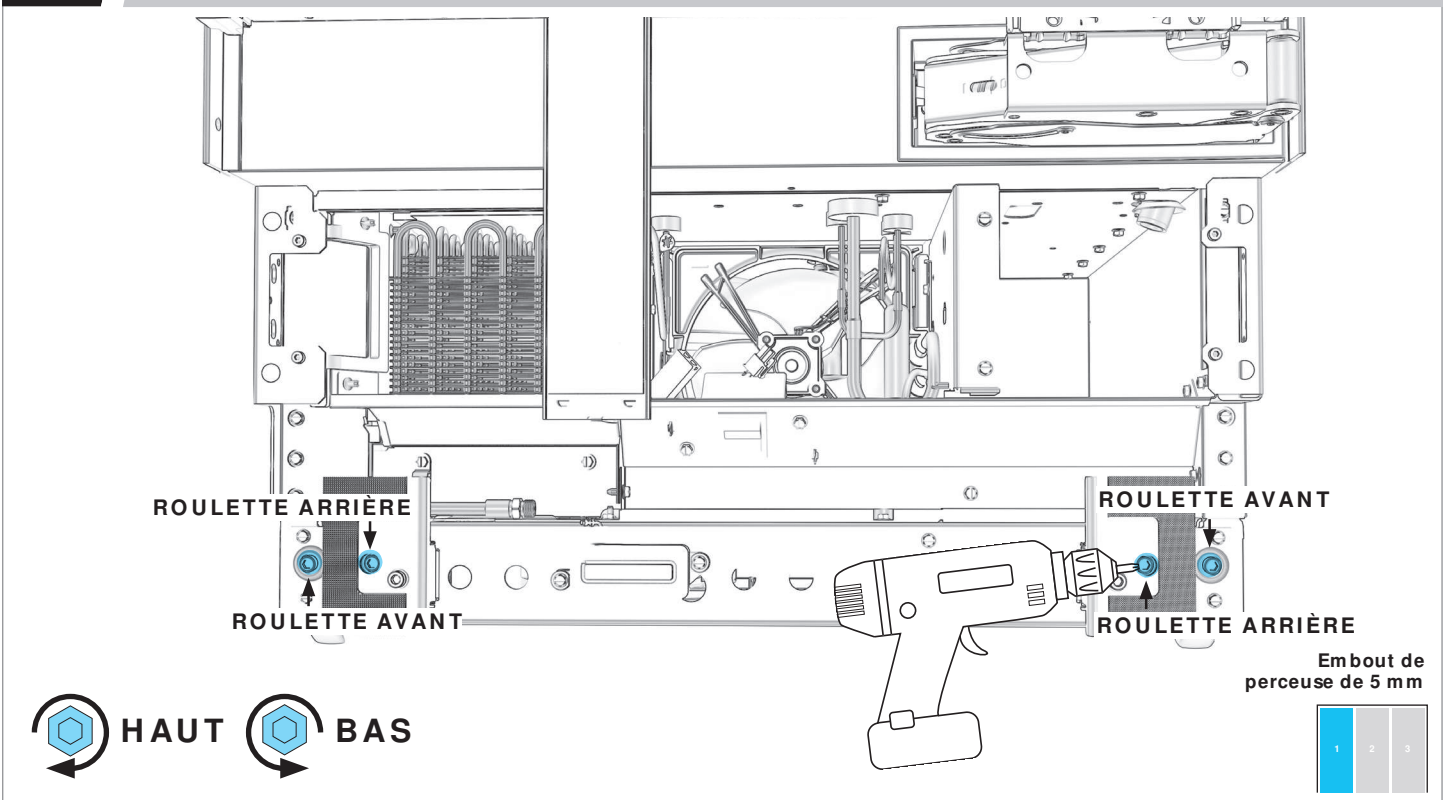

6

INSTALLATION DU PREMIER APPAREIL

6.9

PLACER SANS SERRER DES VIS DANS LA BRIDE D'INSTALLATION ET LA BRIDE BADASS DE SOFFITE.

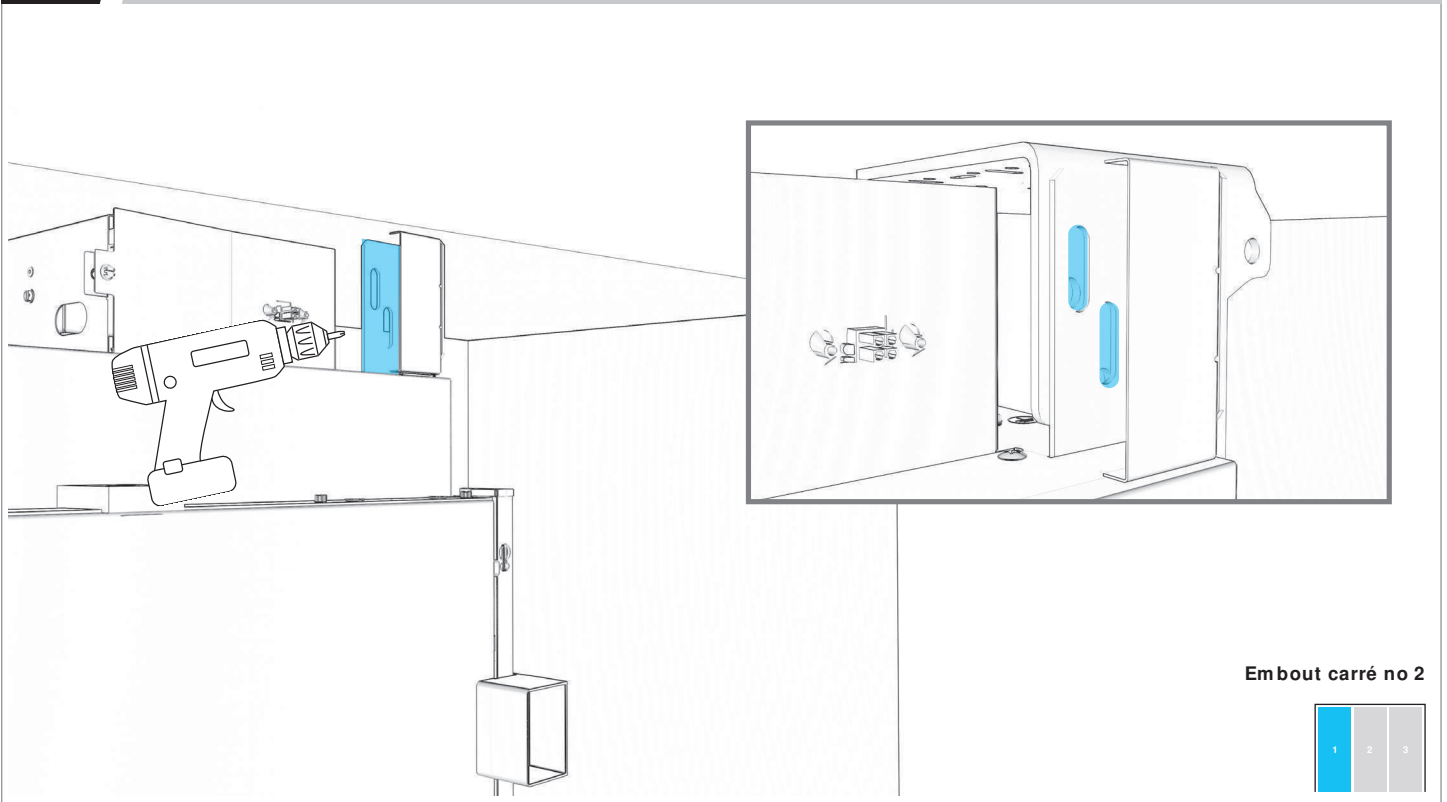

6.10

FIXER LA BRIDE D'INSTALLATION SUPÉRIEURE AU MEUBLE.

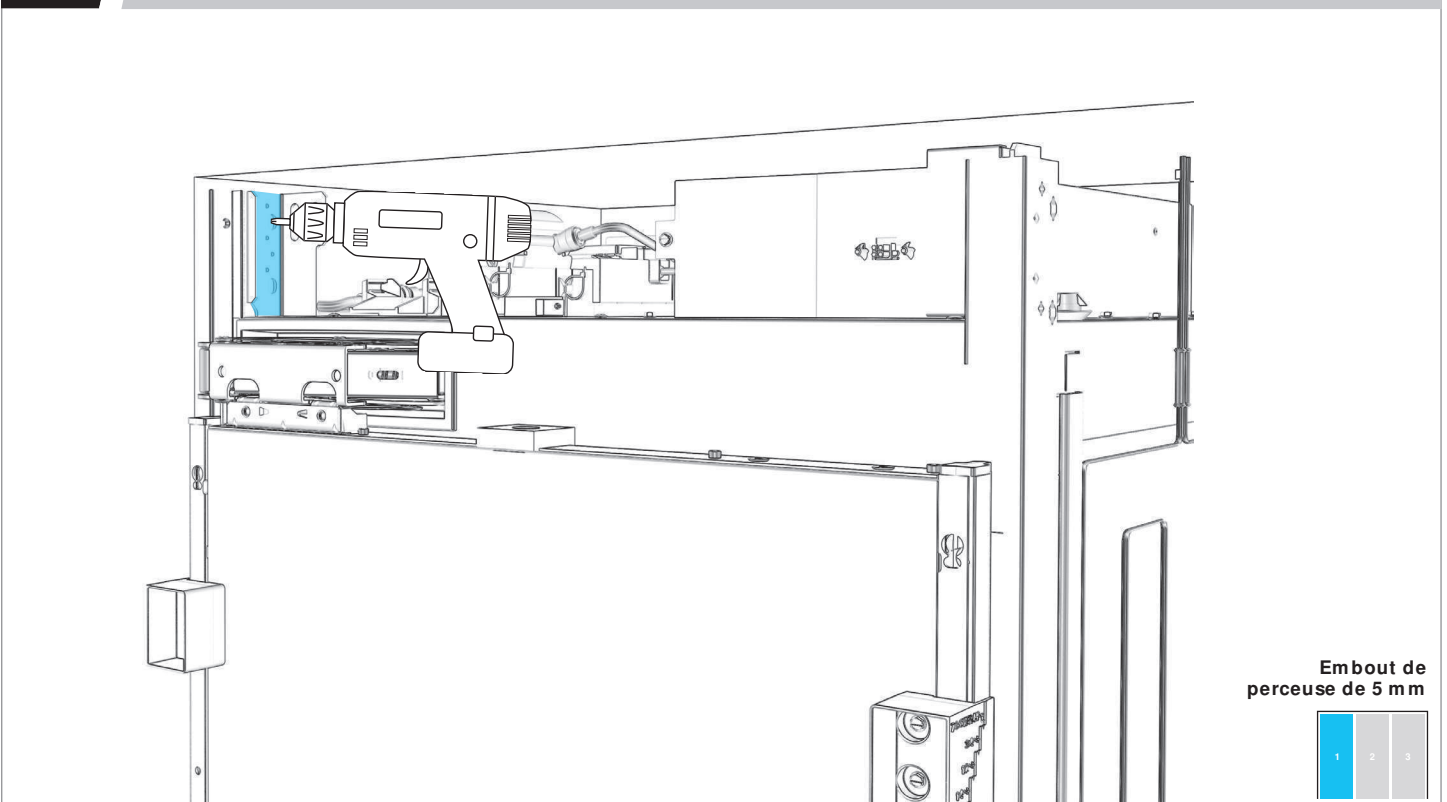

6.11

FIXER LA BRIDE D'INSTALLATION INFÉRIEURE AU MEUBLE.

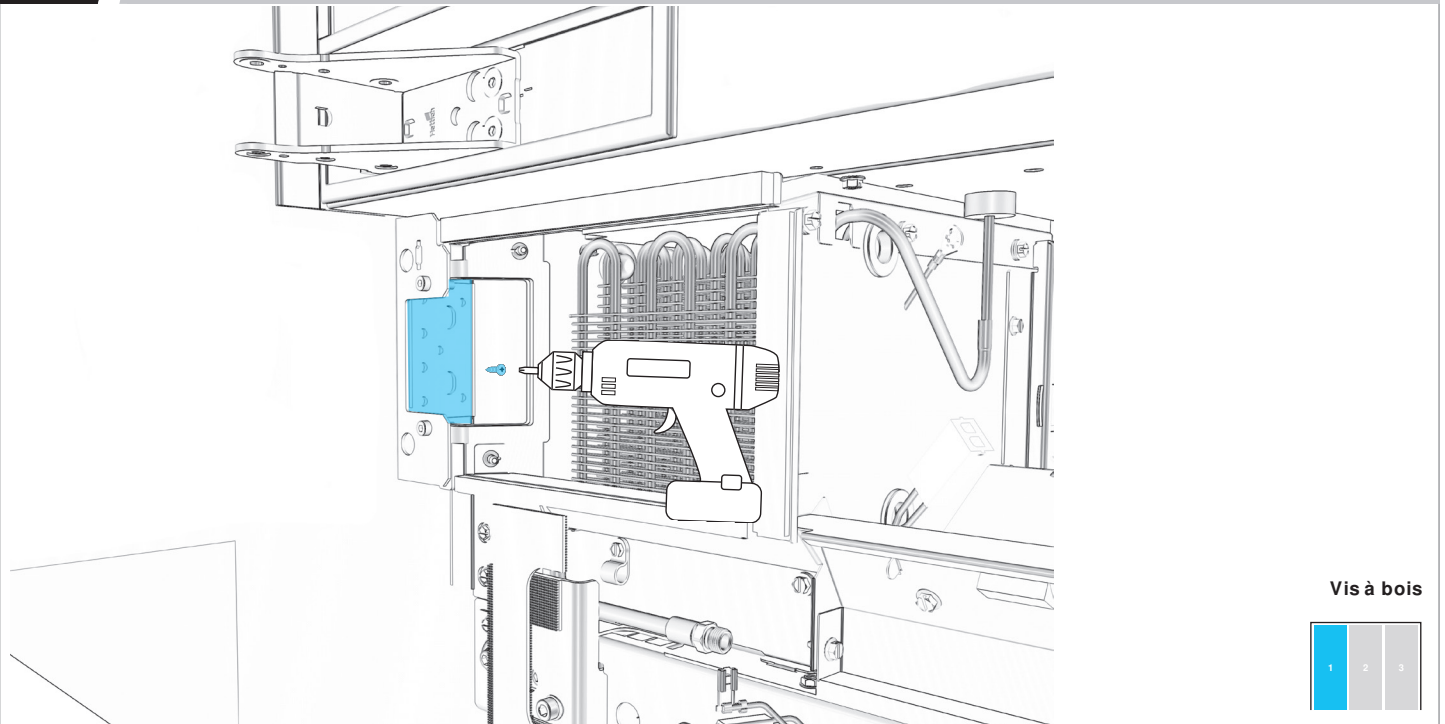

Vis à bois



UTILISER DES VIS À BOIS D'UNE LONGUEUR CONVENABLE.

6.12

PLACER LES BRIDES AU PLANCHER ET AU MUR.

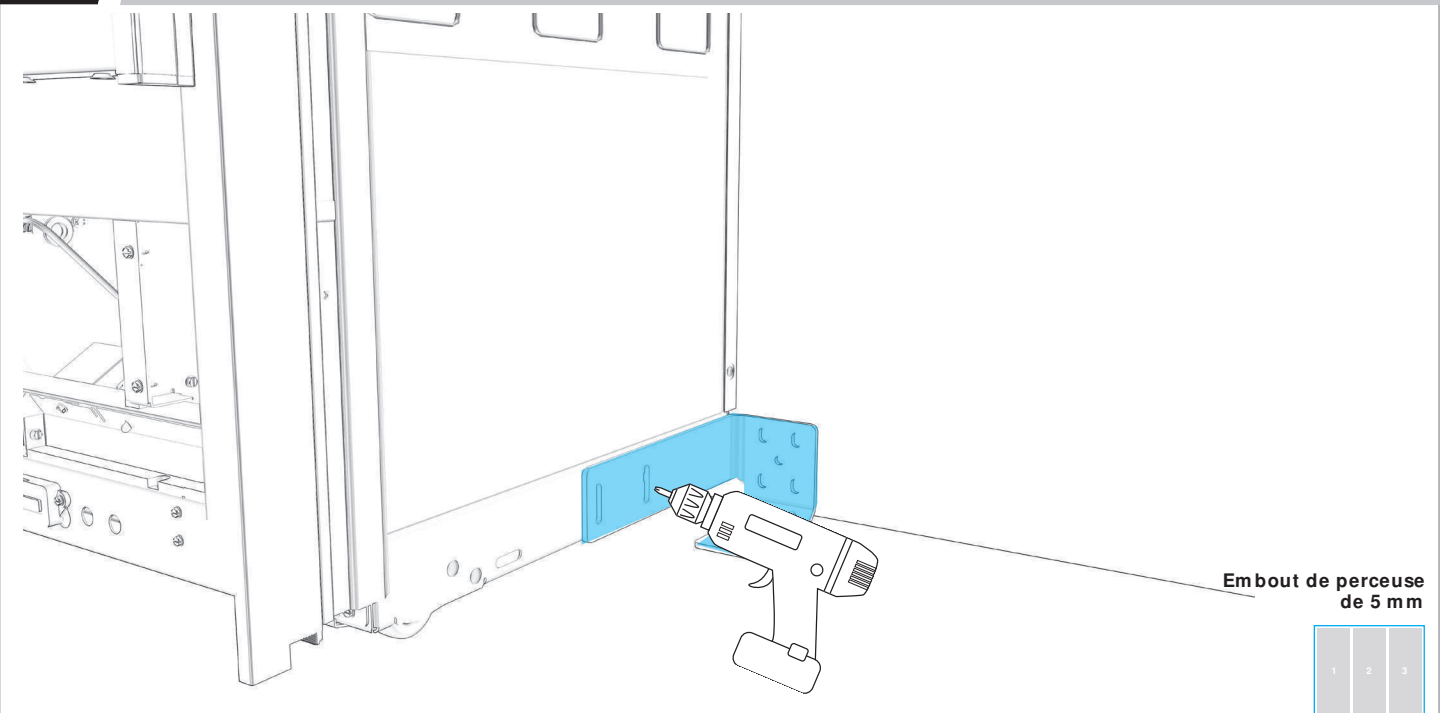

Embout de perceuse
de 5 mm



ÉVALUER LES MATÉRIAUX DE FABRICATION DU MUR ET DU PLANCHER.

6

INSTALLATION DU PREMIER APPAREIL

6.13

FIXER LA BRIDE DE POSITIONNEMENT EN UTILISANT AUTANT DE FENTES QUE POSSIBLE.

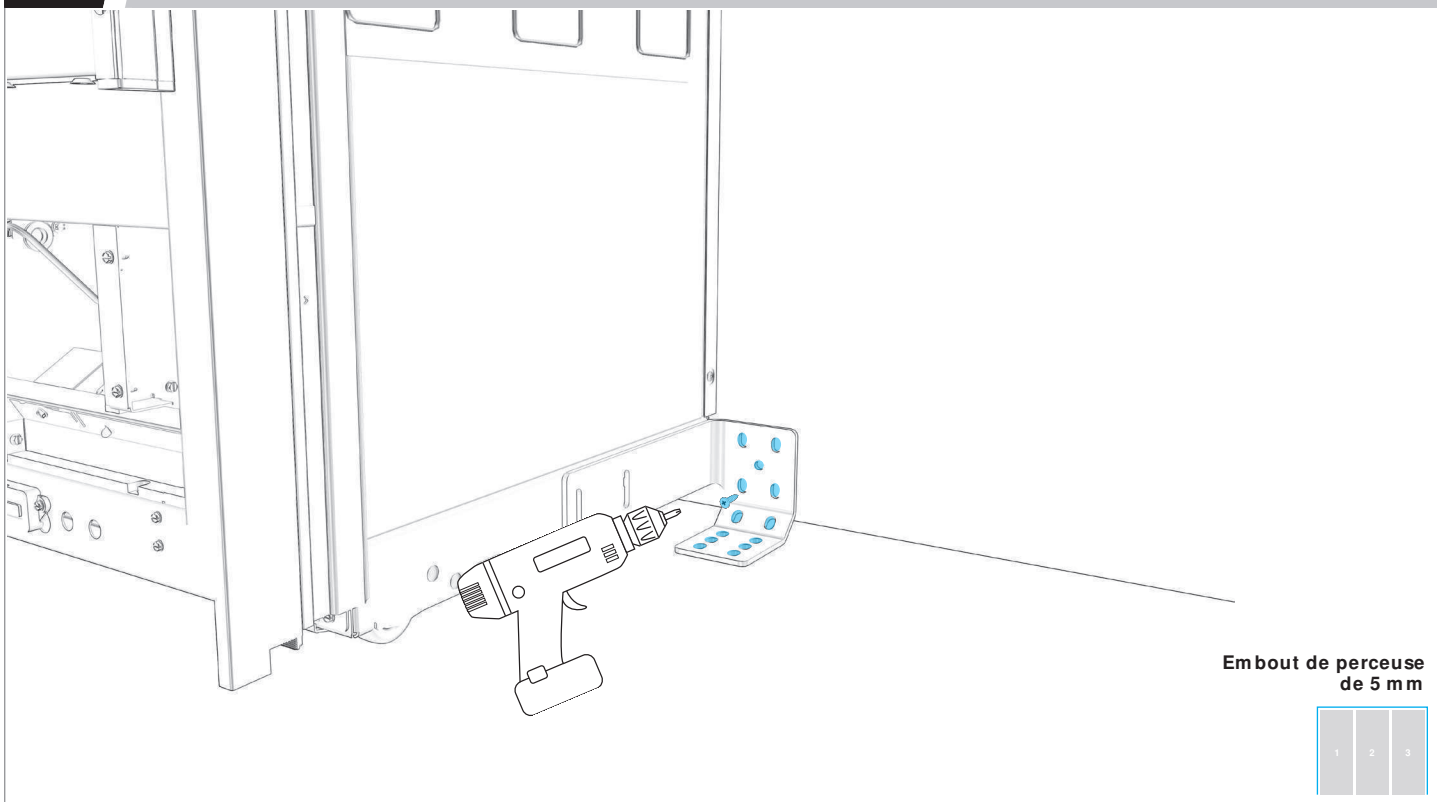

6.14

UTILISER UN NIVEAU POUR VÉRIFIER LA PROFONDEUR À PLUSIEURS EMPLACEMENTS À PARTIR DU CADRE DE FACE.

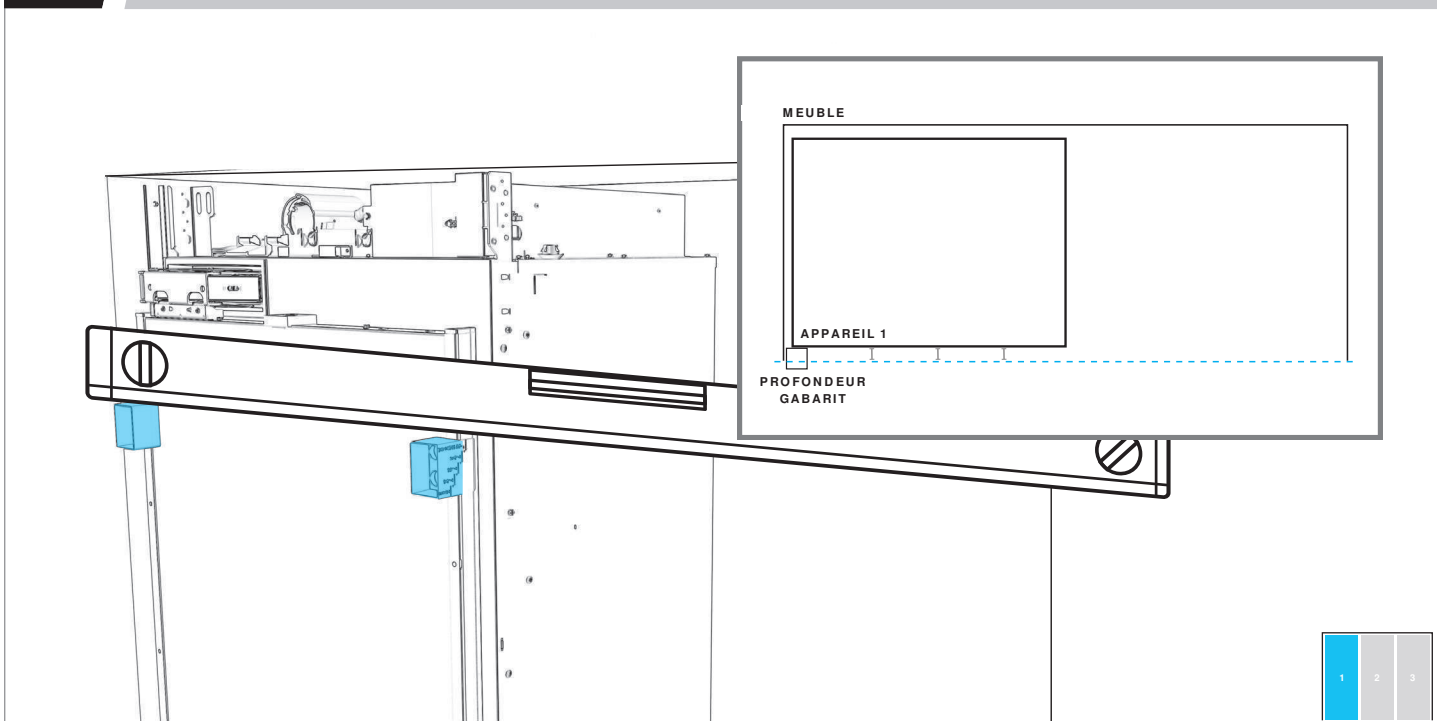

PEUT REMPLACER LES CALES POUR LE NIVELLEMENT.

6.15

AJUSTER DE NOUVEAU L'APPAREIL POUR QUE TOUTES LES PROFONDEURS CORRESPONDENT.

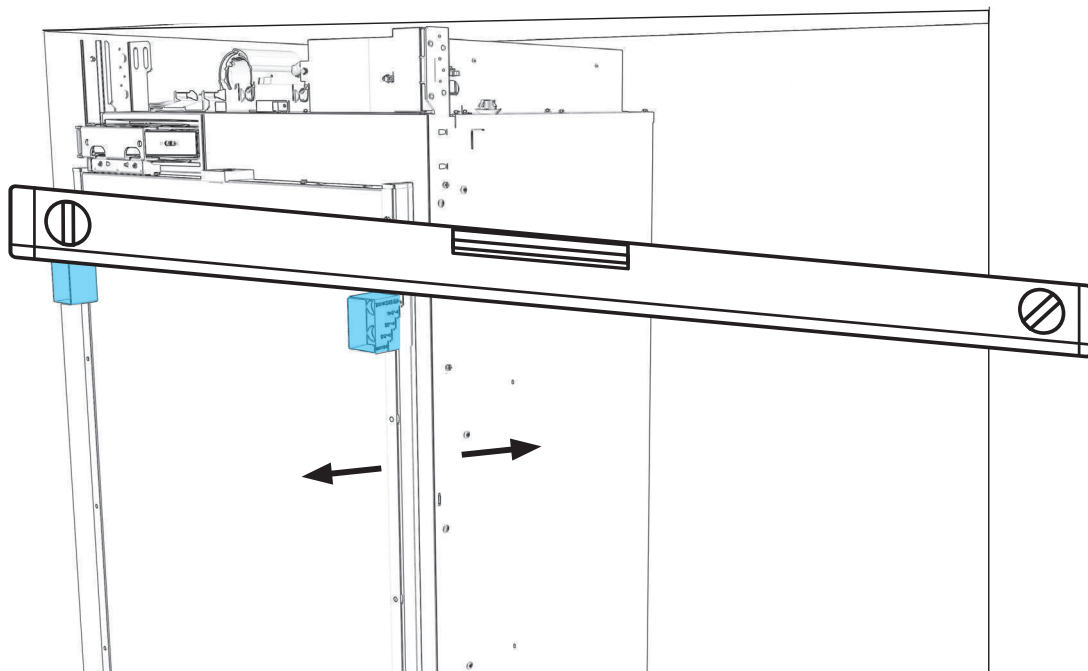



INSTALLATION DU
D E U X I È M E
APPAREIL

7.1

ÉTEINDRE L'ALIMENTATION.

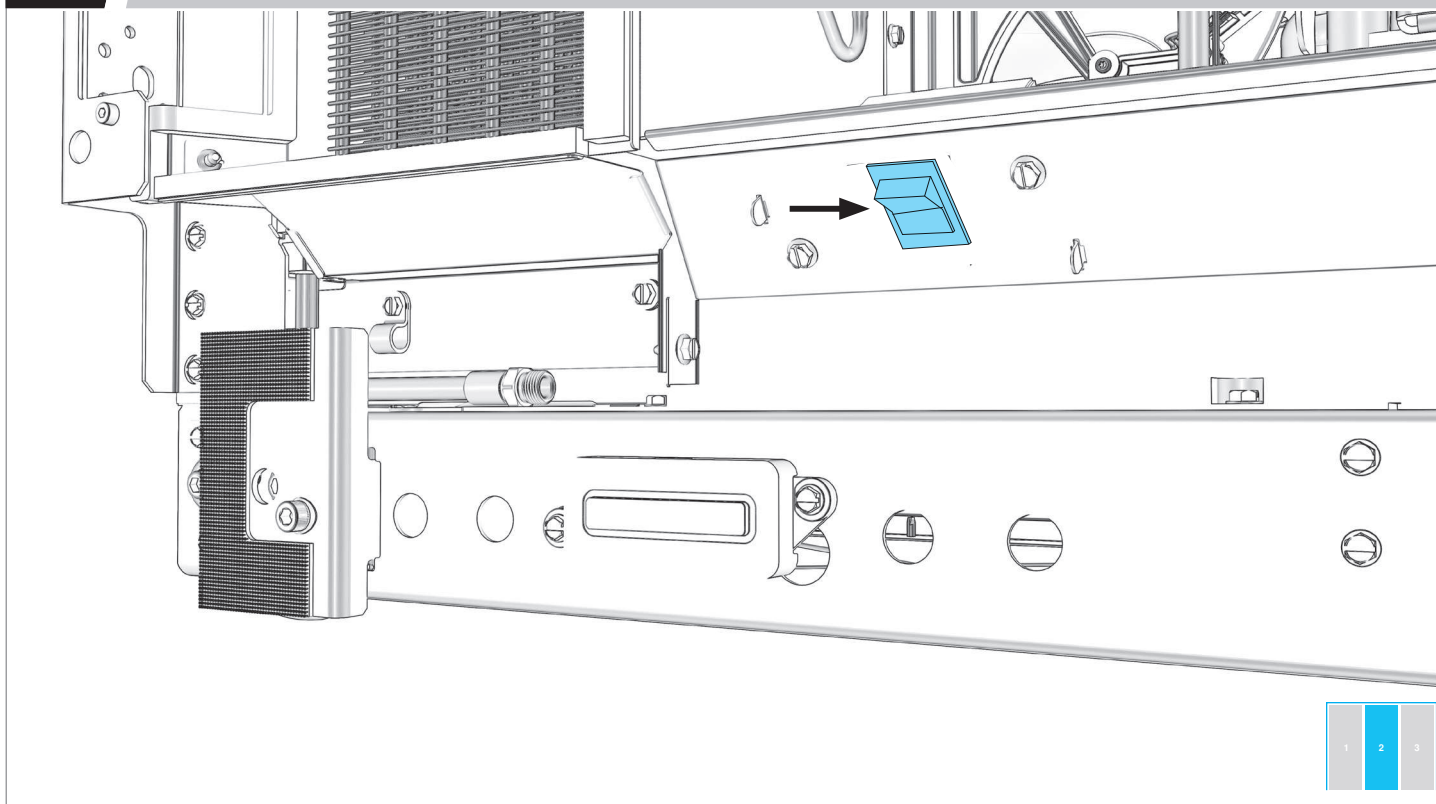

AVANT DE BRANCHER L'APPAREIL, LIRE LES AVERTISSEMENTS.

⚠ AVERTISSEMENT



Risque de choc électrique

Brancher sur une prise à 3 alvéoles reliée à la terre.

Ne pas enlever la broche de liaison à la terre.

Ne pas utiliser un adaptateur.

Ne pas utiliser un câble de rallonge.

Le non-respect de ces instructions peut causer un décès, un incendie ou un choc électrique.

7.2

BRANCHER À UNE PRISE À TROIS ALVÉOLES RELIÉE À LA TERRE.

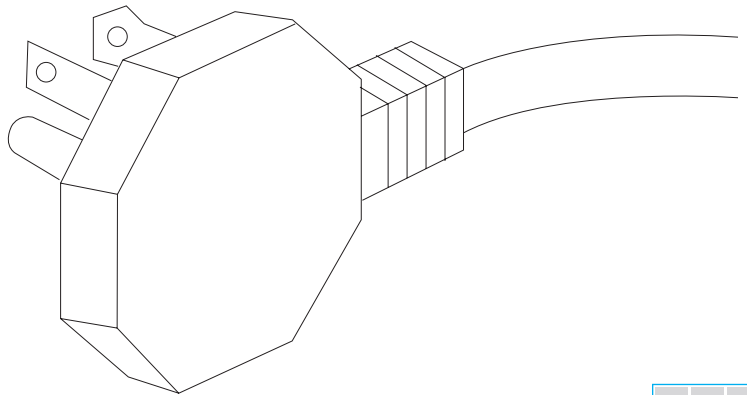
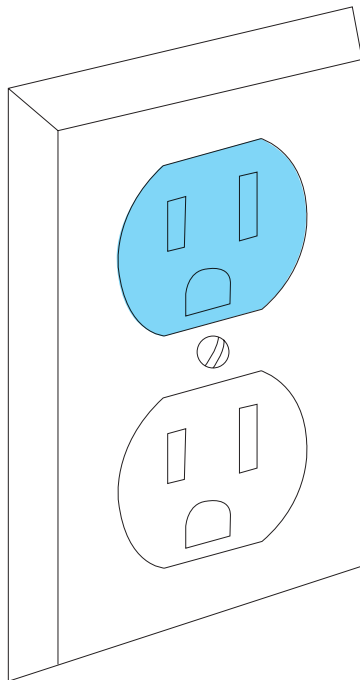

AVANT DE DÉPLACER L'APPAREIL, LIRE TOUS LES AVERTISSEMENTS.

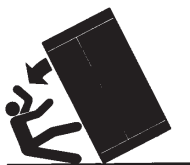
⚠ AVERTISSEMENT**Risque de basculement**

Le réfrigérateur est lourd au sommet et bascule facilement lorsqu'il n'est pas complètement installé.

Garder les portes fermées avec un ruban adhésif jusqu'à l'installation complète du réfrigérateur.

Utiliser deux ou plus de personnes pour déplacer et installer le réfrigérateur.

Le non-respect de ces instructions peut causer un décès ou une blessure grave.

Déplacement de votre réfrigérateur :

Votre réfrigérateur est lourd. Lors du déplacement de votre réfrigérateur pour le nettoyage ou un entretien ou réparation, veiller à recouvrir le plancher avec du carton ou un panneau de fibres dures pour éviter qu'il ne subisse tout dommage. Toujours tirer le réfrigérateur tout droit lors de son déplacement. Ne pas incliner le réfrigérateur d'un côté ou de l'autre ni le "faire marcher" en essayant de le déplacer car le plancher pourrait être endommagé.

Importants renseignements à savoir au sujet des tablettes et des couvercles en verre :

Ne pas nettoyer les tablettes ou couvercles en verre avec de l'eau tiède quand ils sont froids. Les tablettes et les couvercles peuvent se briser s'ils sont exposés à des changements soudains de température ou à un impact tel que coup brusque. Le verre trempé est conçu pour éclater en d'innombrables pièces minuscules. Ceci est normal. Les tablettes et les couvercles en verre sont lourds. Les saisir à deux mains lors de leur dépose afin d'éviter de les faire tomber.

7.3

DEUXIÈME APPAREIL : PLACER DANS L'OUVERTURE.

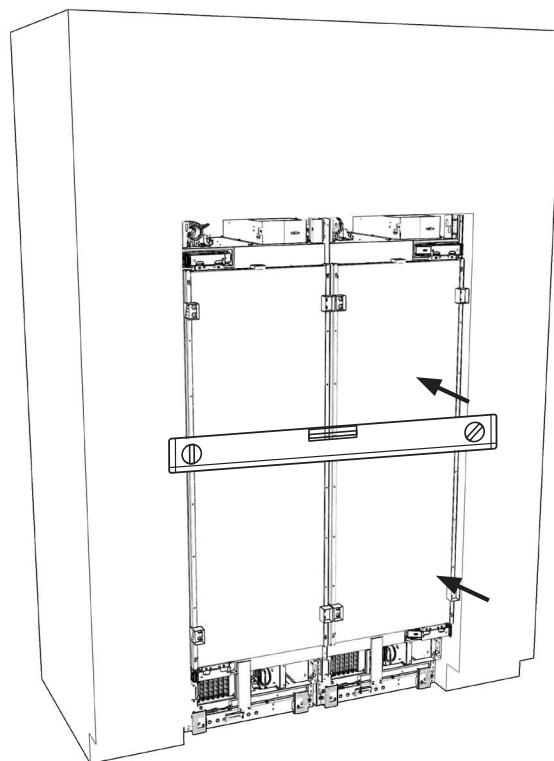

7.4

SI UN TROISIÈME APPAREIL EST INSTALLÉ :
PASSER À LA SECTION 8

7

INSTALLATION DU DEUXIÈME APPAREIL

7.5

DEUXIÈME APPAREIL : PLACER À LA LIGNE DE 84 po.

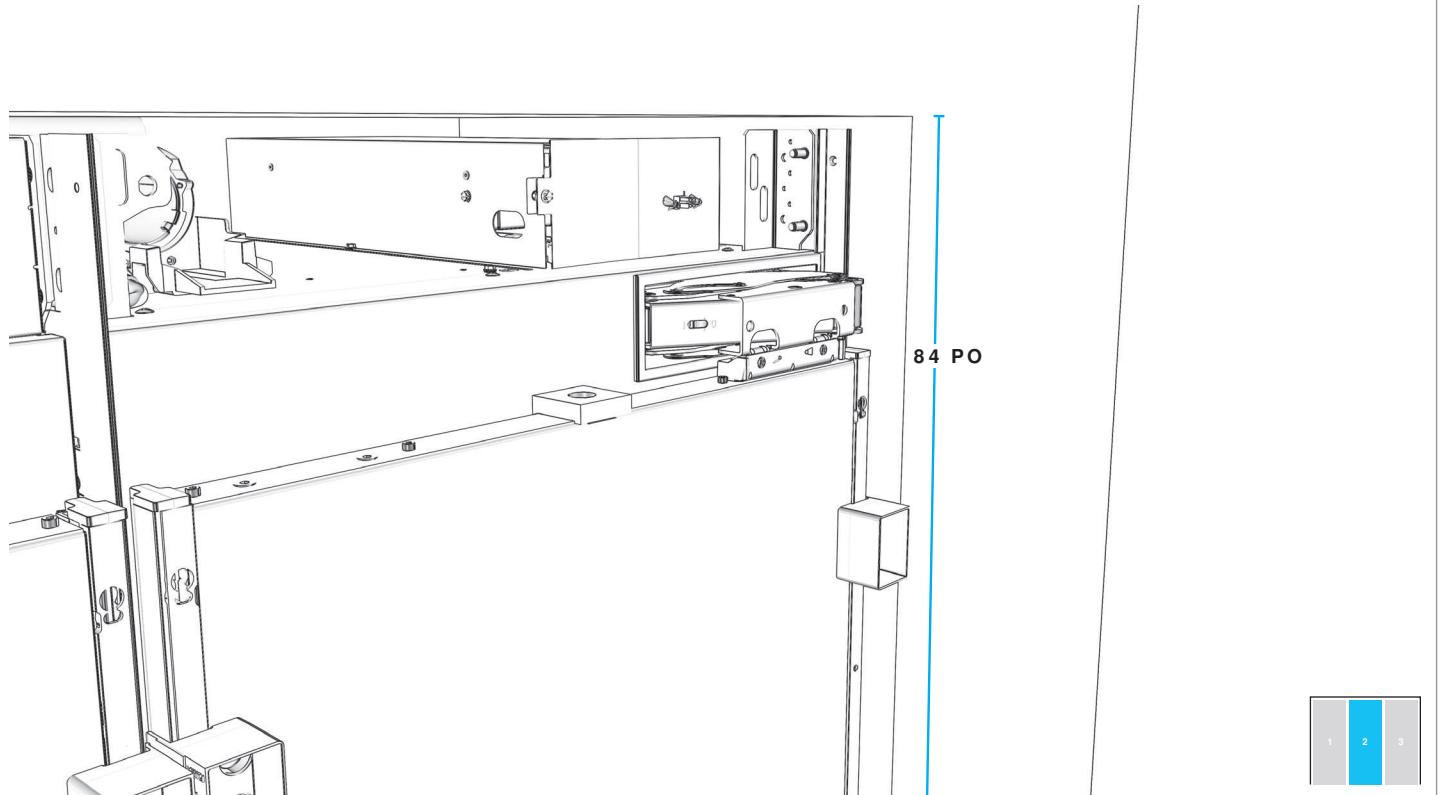

7.6

FIXER LE HAUT DU PREMIER APPAREIL AU DEUXIÈME APPAREIL.

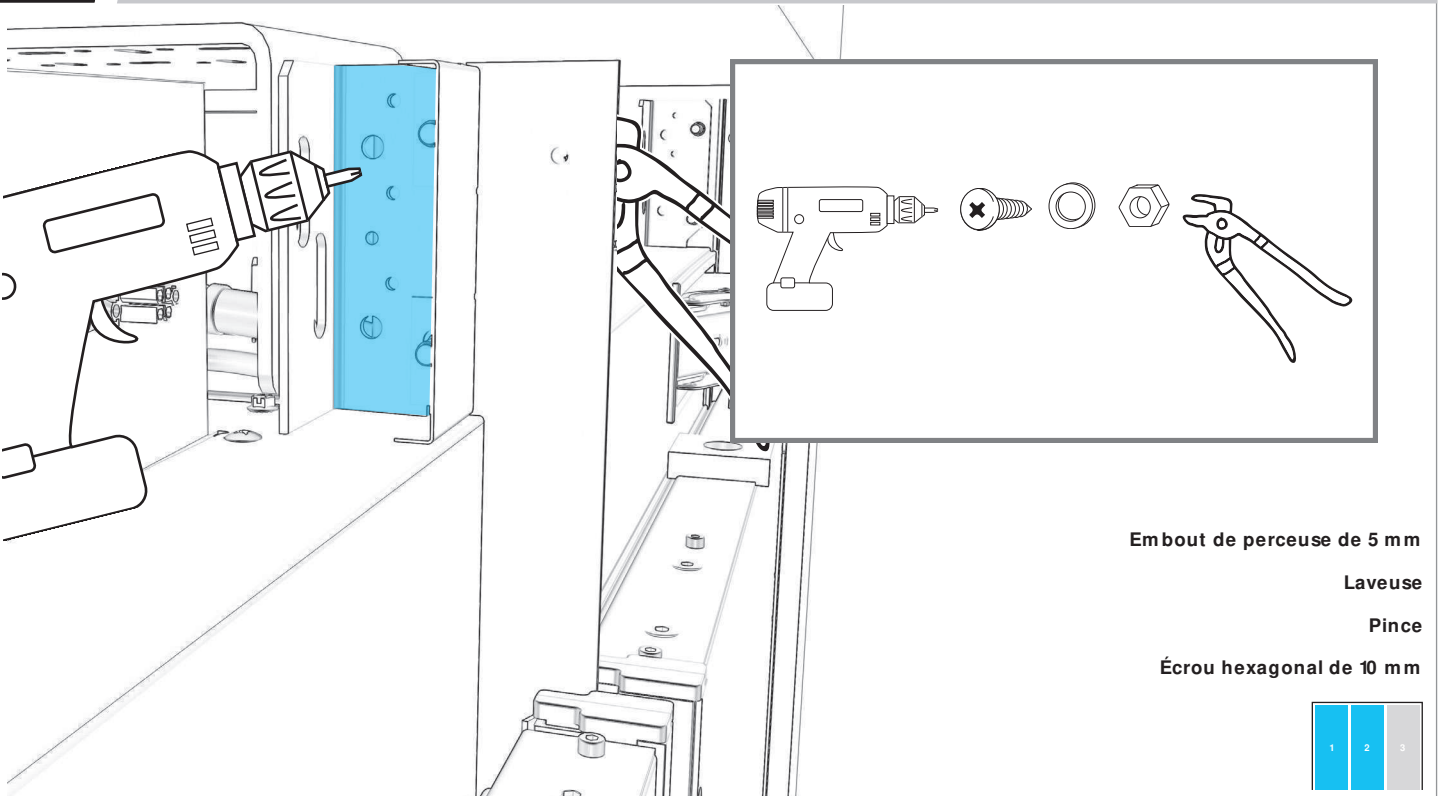

Embout de perceuse de 5 mm

Laveuse

Pince

Écrou hexagonal de 10 mm

7.7

RÉPÉTER POUR LA BRIDE DU BAS.

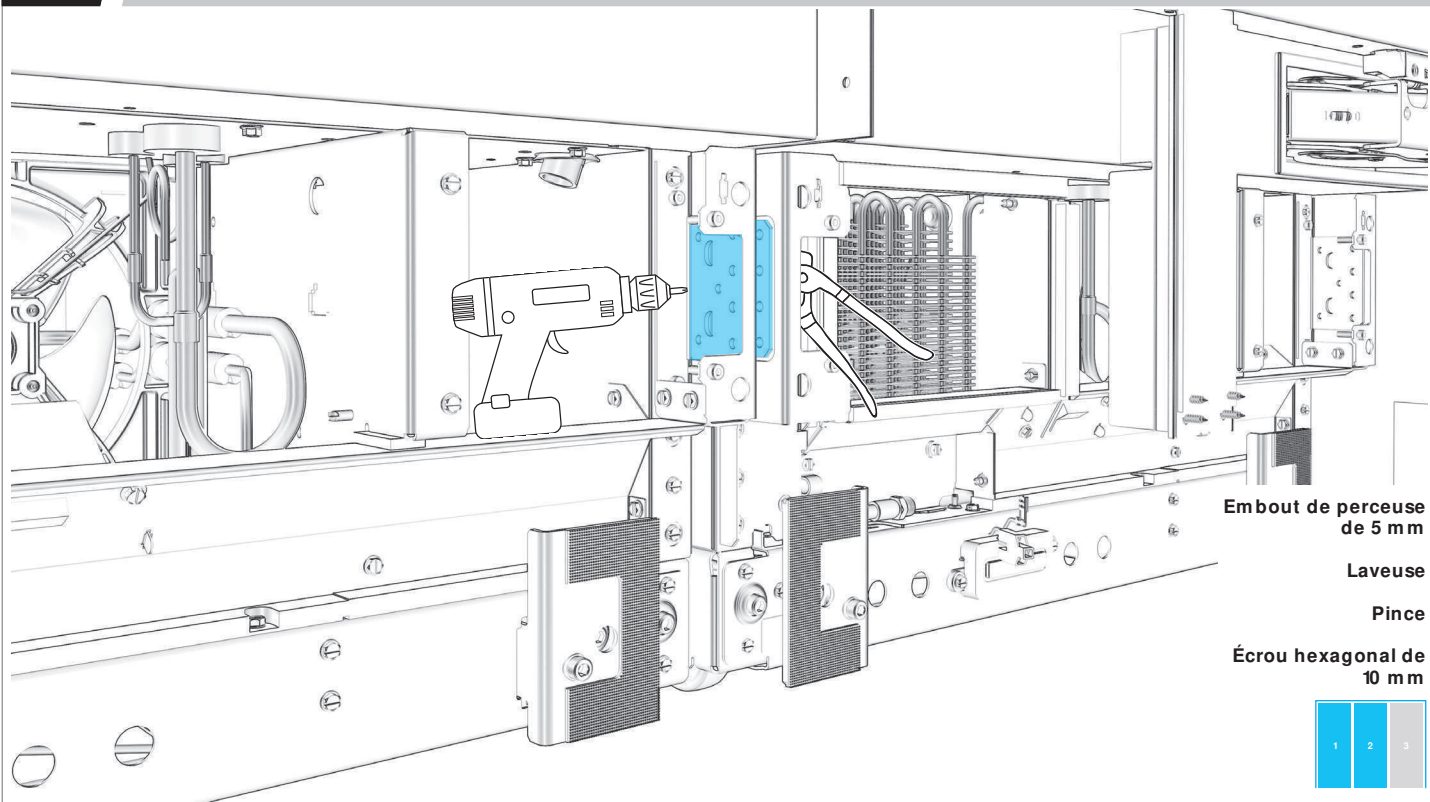

Embout de perceuse
de 5 mm

Laveuse

Pince

Écrou hexagonal de
10 mm

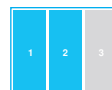

7.8

FIXER LA BRIDE D'INSTALLATION SUPÉRIEURE AU MEUBLE.

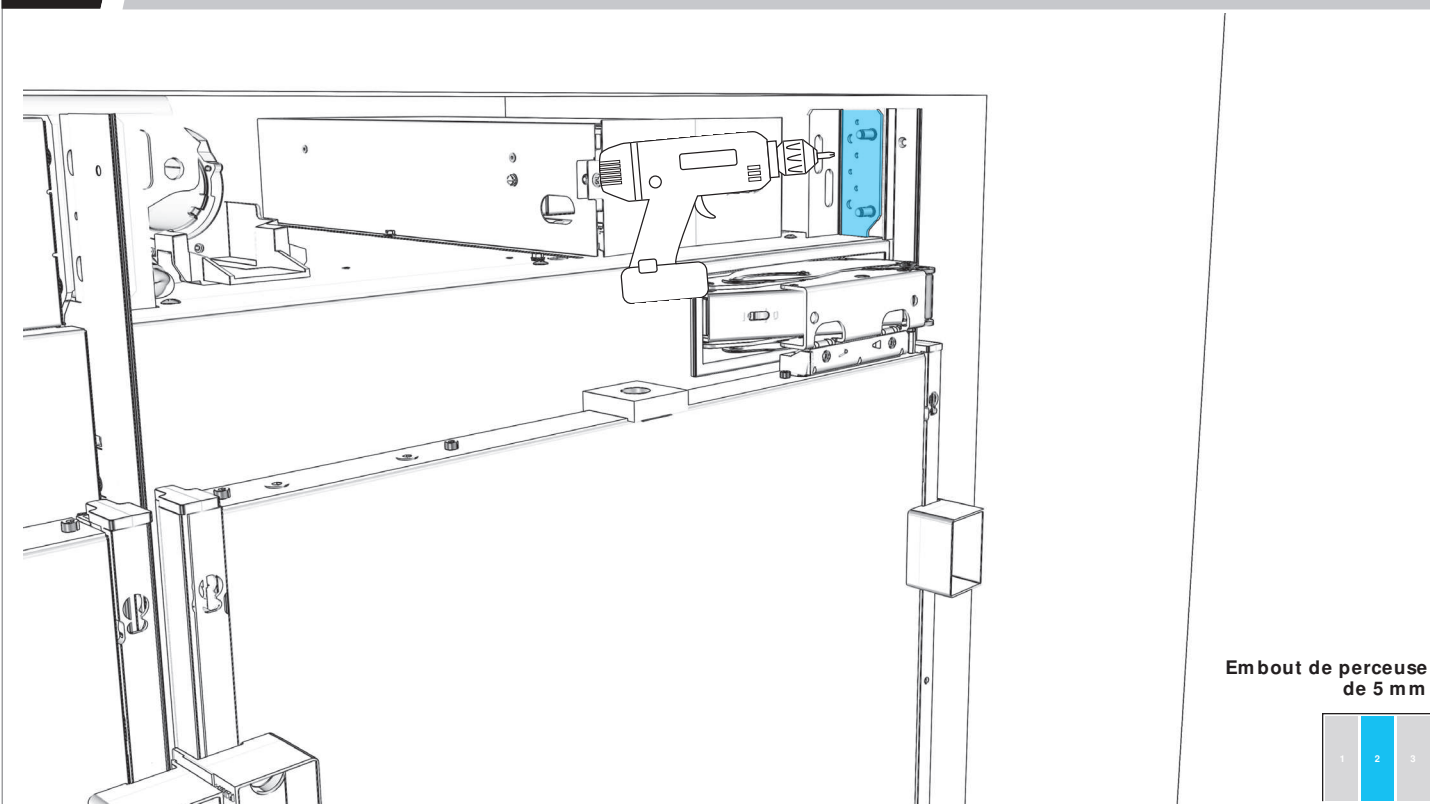

Embout de perceuse
de 5 mm

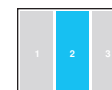

7

INSTALLATION DU DEUXIÈME APPAREIL

7.9

FIXER LA BRIDE D'INSTALLATION INFÉRIEURE AU MEUBLE.

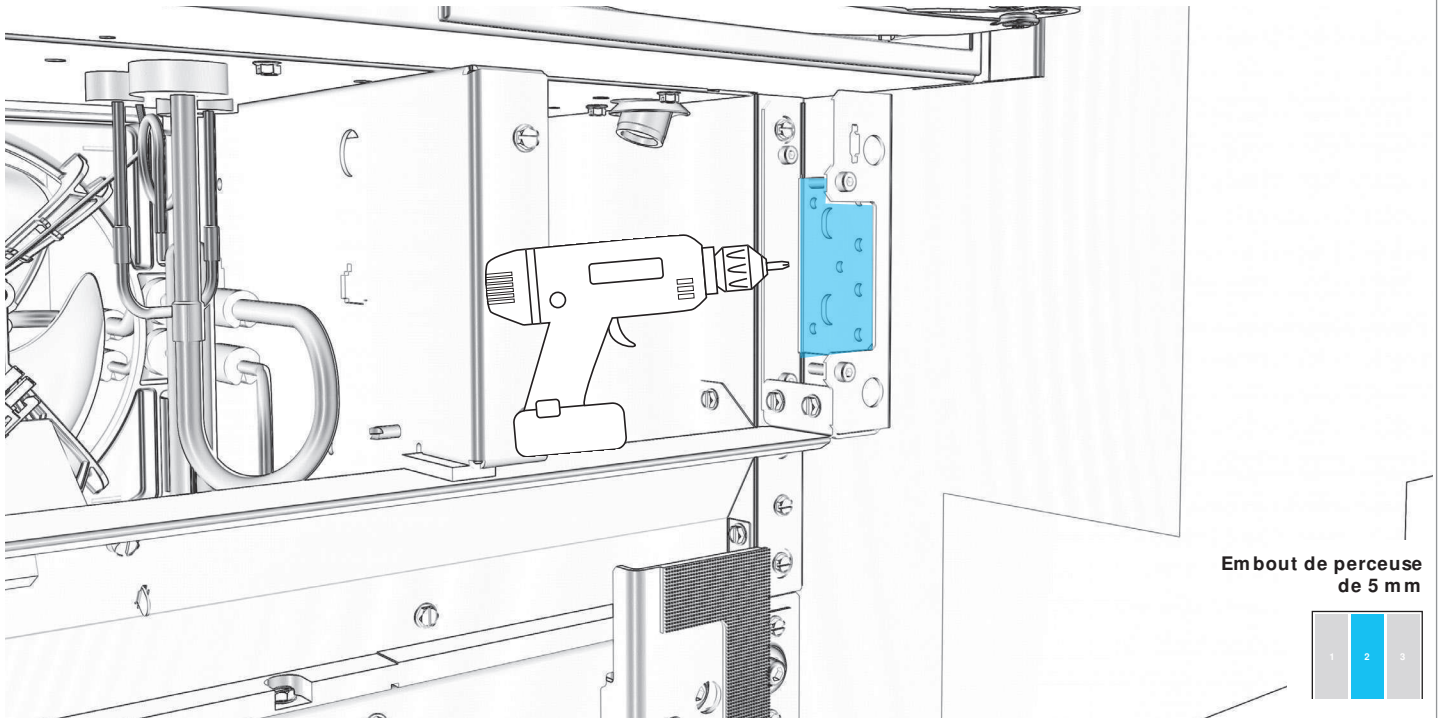

Embout de perceuse de 5 mm



UTILISER DES VIS À BOIS D'UNE LONGUEUR CONVENABLE

7.10

RACCORDER LES TUYAUX D'ARRIVÉE D'EAU.

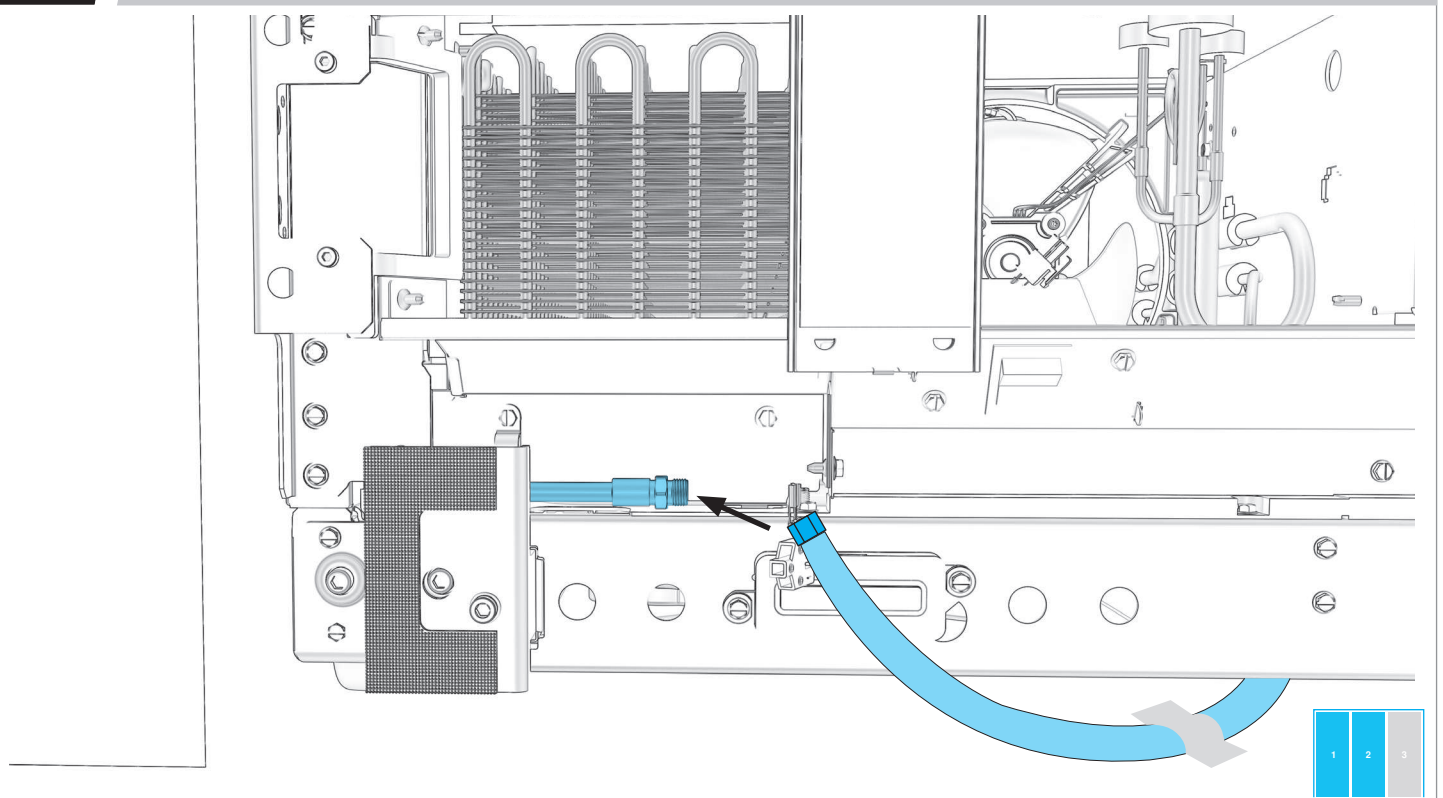

7.11

SI SEULEMENT DEUX APPAREILS SONT INSTALLÉS :
PASSER À LA SECTION 9

INSTALLATION DU
FRIGOSISÈME
APPAREIL

8.1 DEUXIÈME APPAREIL : PLACER À LA LIGNE DE 84 PO.

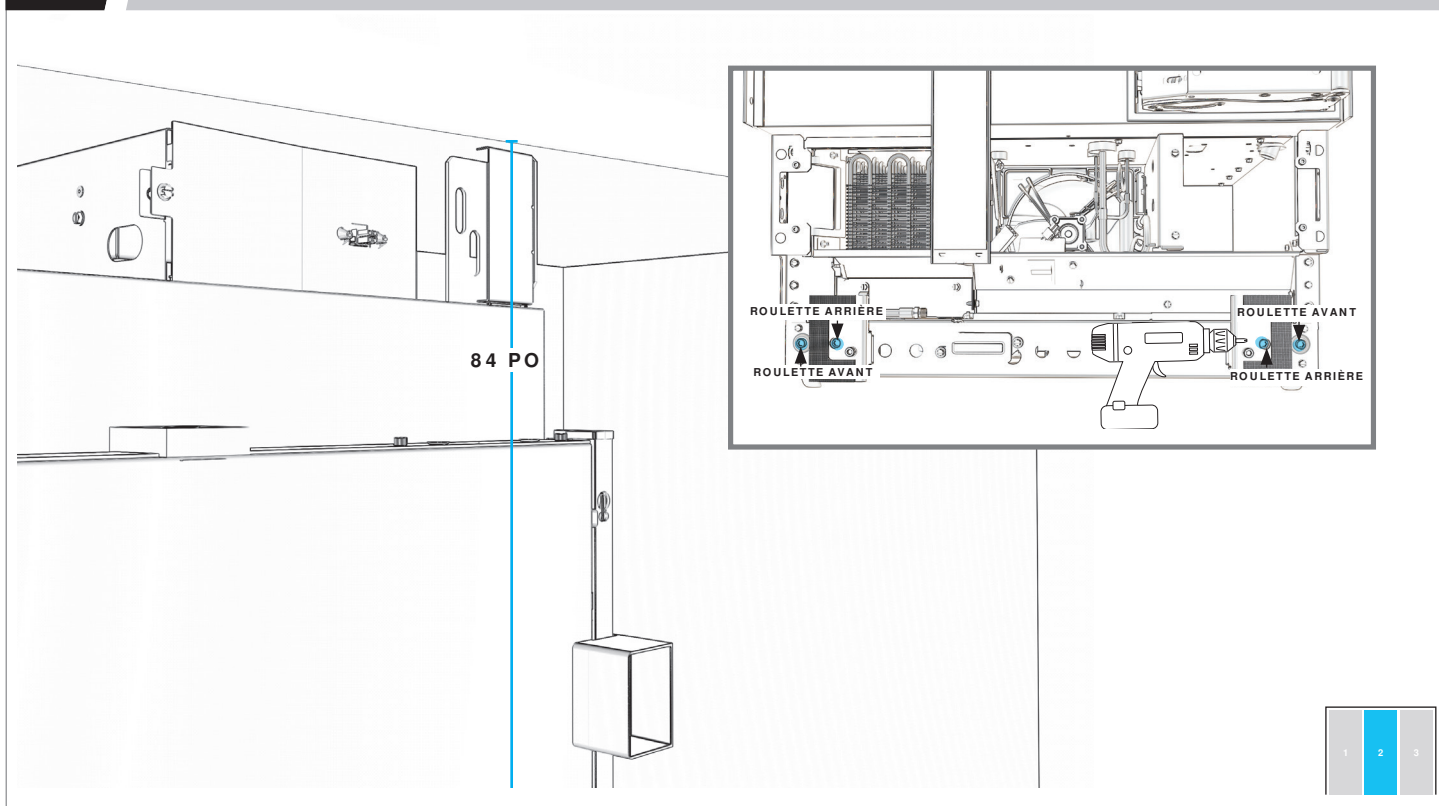

8.2 DEUXIÈME APPAREIL : FIXER LA BRIDE DE POSITIONNEMENT.

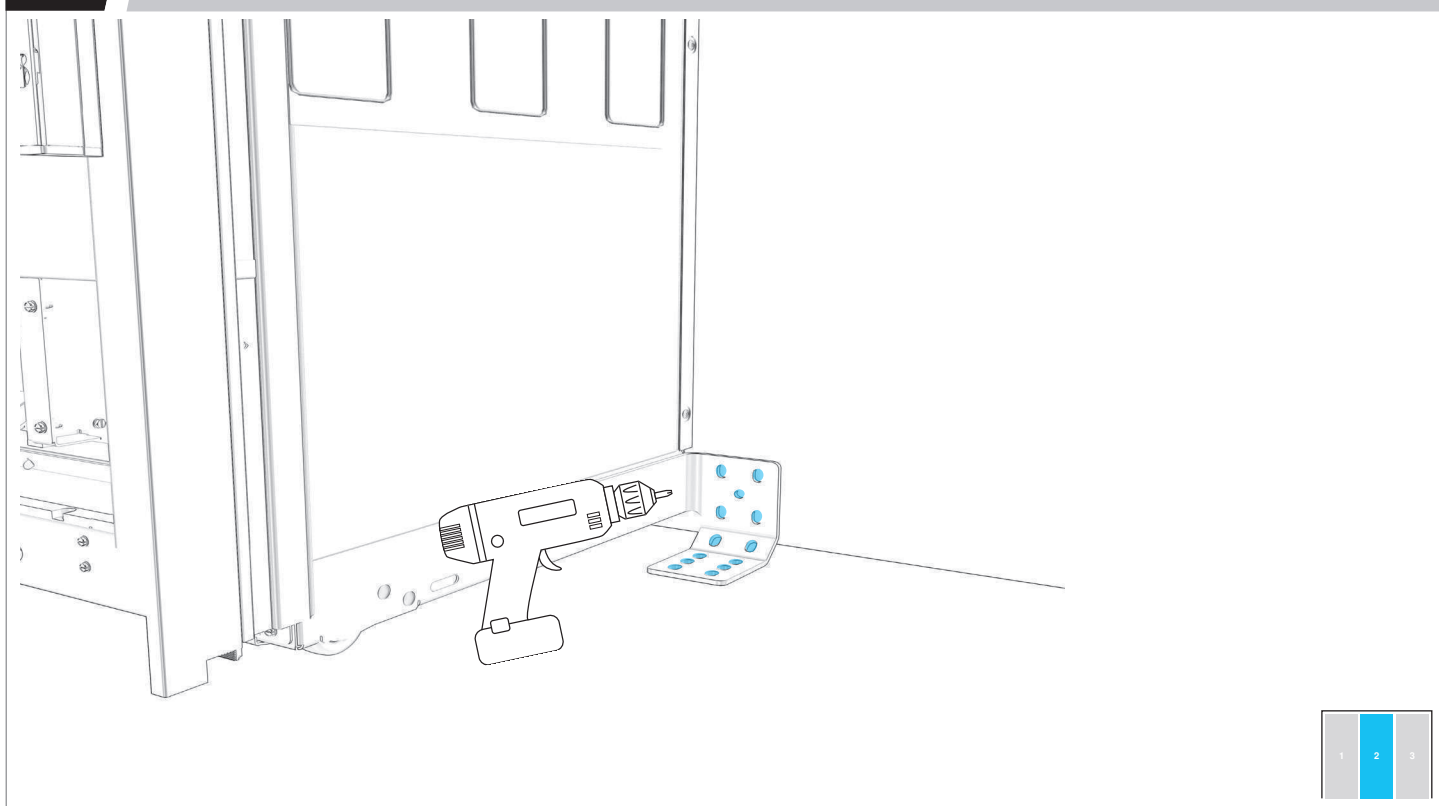

8

INSTALLATION DU TROISIÈME APPAREIL

8.3

PLACER SANS SERRER DES VIS DANS LA BRIDE D'INSTALLATION ET LA BRIDE BADASS DE SOFFITE.

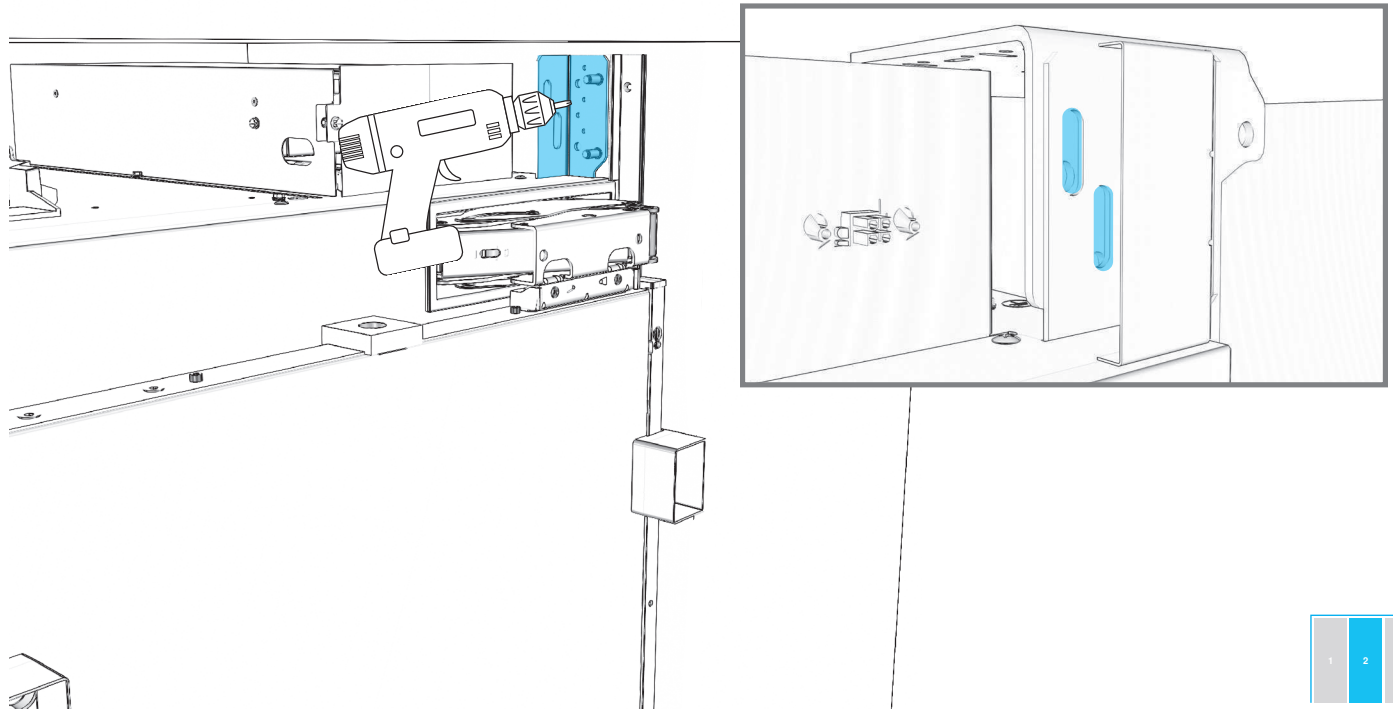

8.4

TROISIÈME APPAREIL : ÉTEINDRE L'ALIMENTATION.

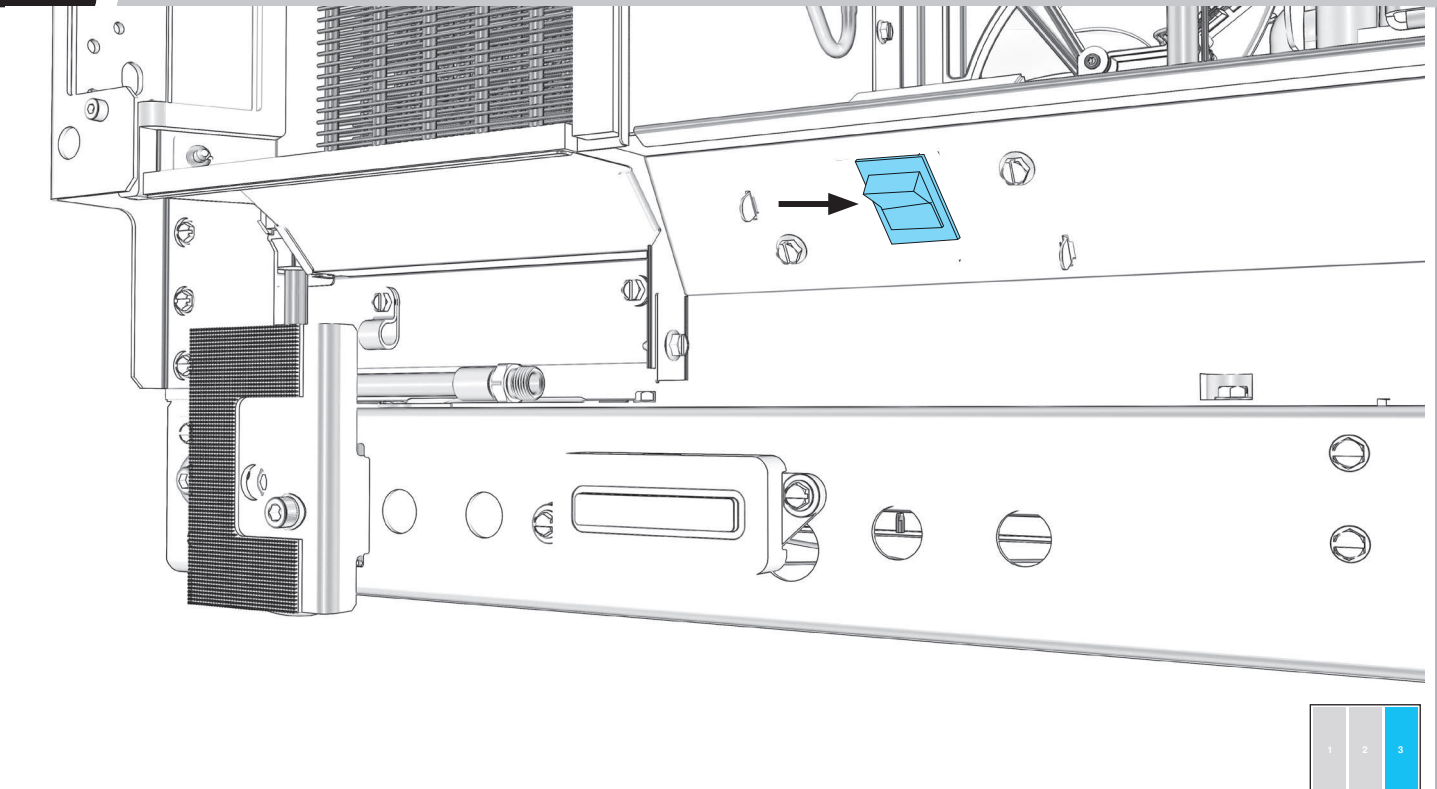

AVANT DE BRANCHER L'APPAREIL, LIRE LES AVERTISSEMENTS.

⚠ AVERTISSEMENT



Risque de choc électrique

Brancher sur une prise à 3 alvéoles reliée à la terre.

Ne pas enlever la broche de liaison à la terre.

Ne pas utiliser un adaptateur.

Ne pas utiliser un câble de rallonge.

Le non-respect de ces instructions peut causer un décès, un incendie ou un choc électrique.

8.5

BRANCHER À UNE PRISE À TROIS ALVÉOLES RELIÉE À LA TERRE.

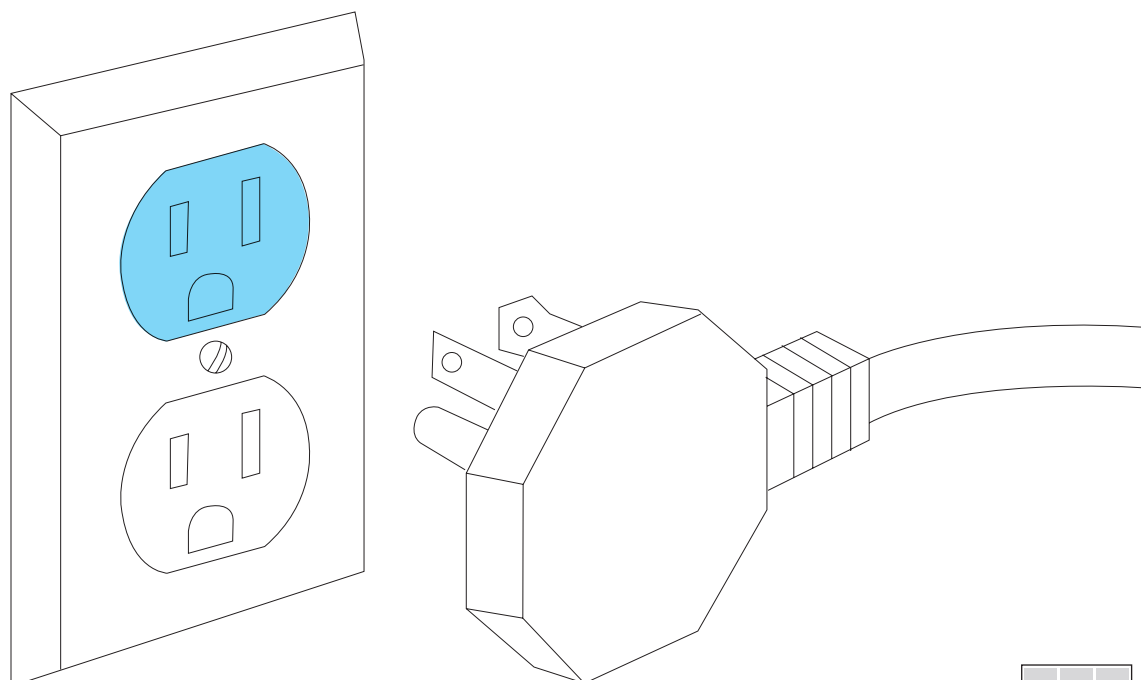

AVANT DE DÉPLACER L'APPAREIL, LIRE TOUS LES AVERTISSEMENTS.

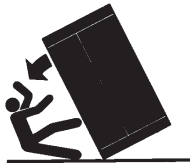
⚠ AVERTISSEMENT**Risque de basculement**

Le réfrigérateur est lourd au sommet et bascule facilement lorsqu'il n'est pas complètement installé.

Garder les portes fermées avec un ruban adhésif jusqu'à l'installation complète du réfrigérateur.

Utiliser deux ou plus de personnes pour déplacer et installer le réfrigérateur.

Le non-respect de ces instructions peut causer un décès ou une blessure grave.

Déplacement de votre réfrigérateur :

Votre réfrigérateur est lourd. Lors du déplacement de votre réfrigérateur pour le nettoyage ou un entretien ou réparation, veiller à recouvrir le plancher avec du carton ou un panneau de fibres dures pour éviter qu'il ne subisse tout dommage. Toujours tirer le réfrigérateur tout droit lors de son déplacement. Ne pas incliner le réfrigérateur d'un côté ou de l'autre ni le "faire marcher" en essayant de le déplacer car le plancher pourrait être endommagé.

Importants renseignements à savoir au sujet des tablettes et des couvercles en verre :

Ne pas nettoyer les tablettes ou couvercles en verre avec de l'eau tiède quand ils sont froids. Les tablettes et les couvercles peuvent se briser s'ils sont exposés à des changements soudains de température ou à un impact tel que coup brusque. Le verre trempé est conçu pour éclater en d'innombrables pièces minuscules. Ceci est normal. Les tablettes et les couvercles en verre sont lourds. Les saisir à deux mains lors de leur dépose afin d'éviter de les faire tomber.

8.7

TROISIÈME APPAREIL : PLACER DANS L'OUVERTURE.

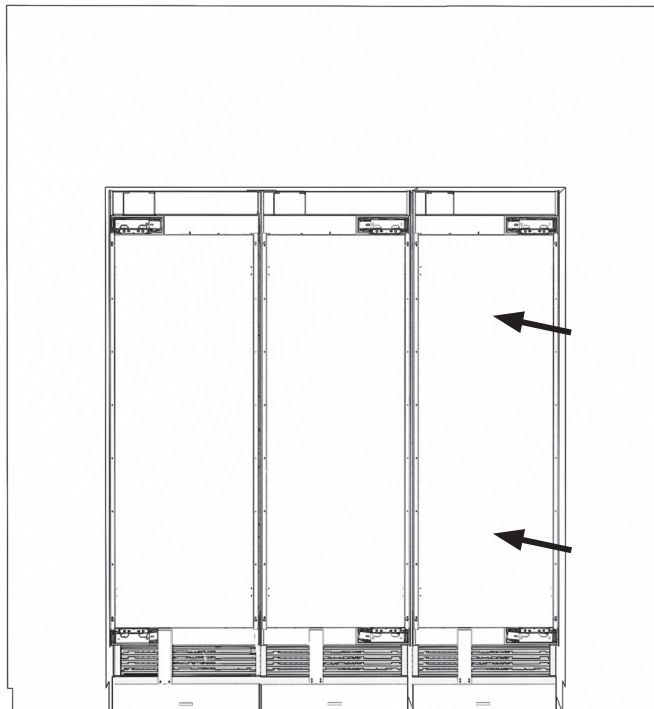

8.8 TROISIÈME APPAREIL : PLACER À LA LIGNE DE 84 PO.

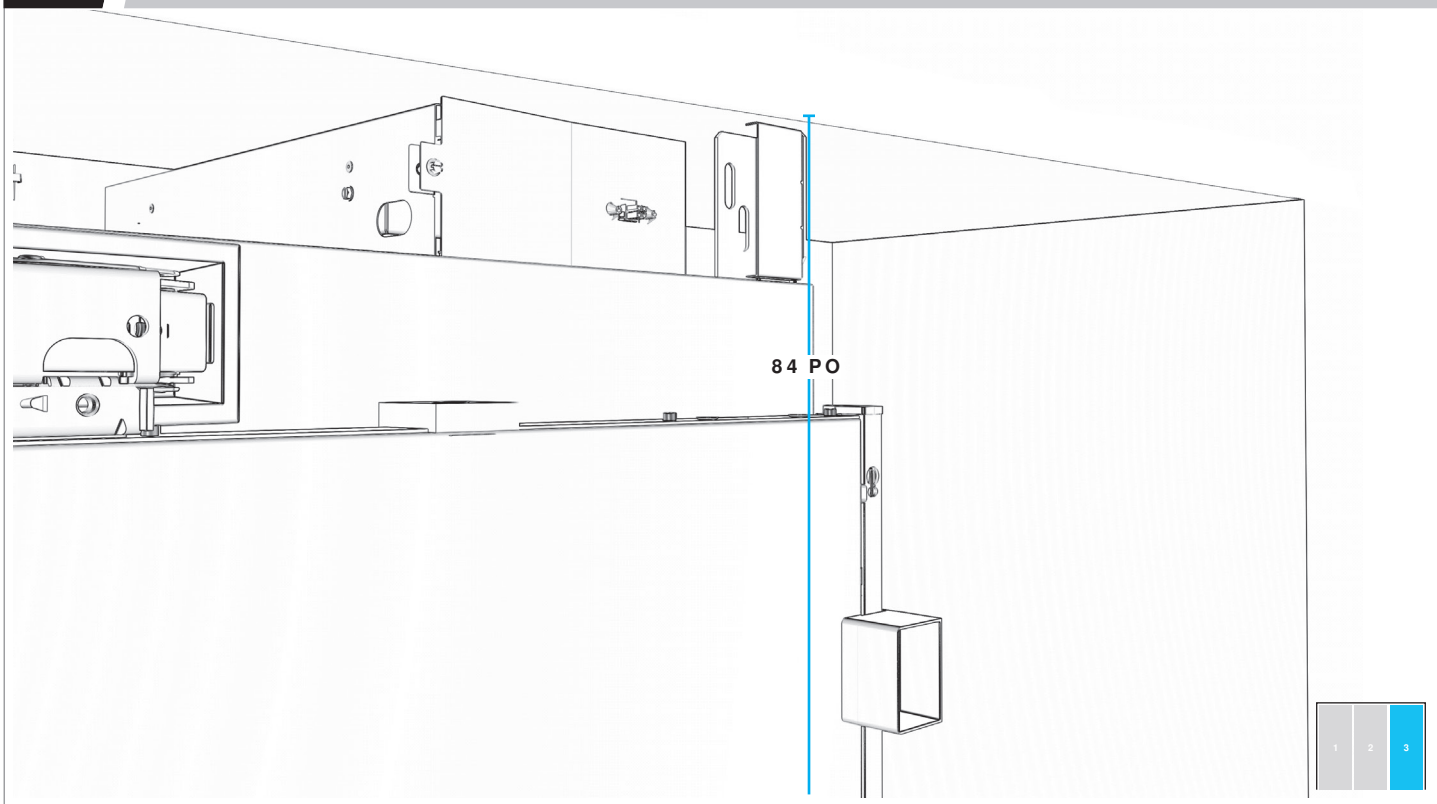

8.9 FIXER LE HAUT DU DEUXIÈME APPAREIL AU TROISIÈME APPAREIL.

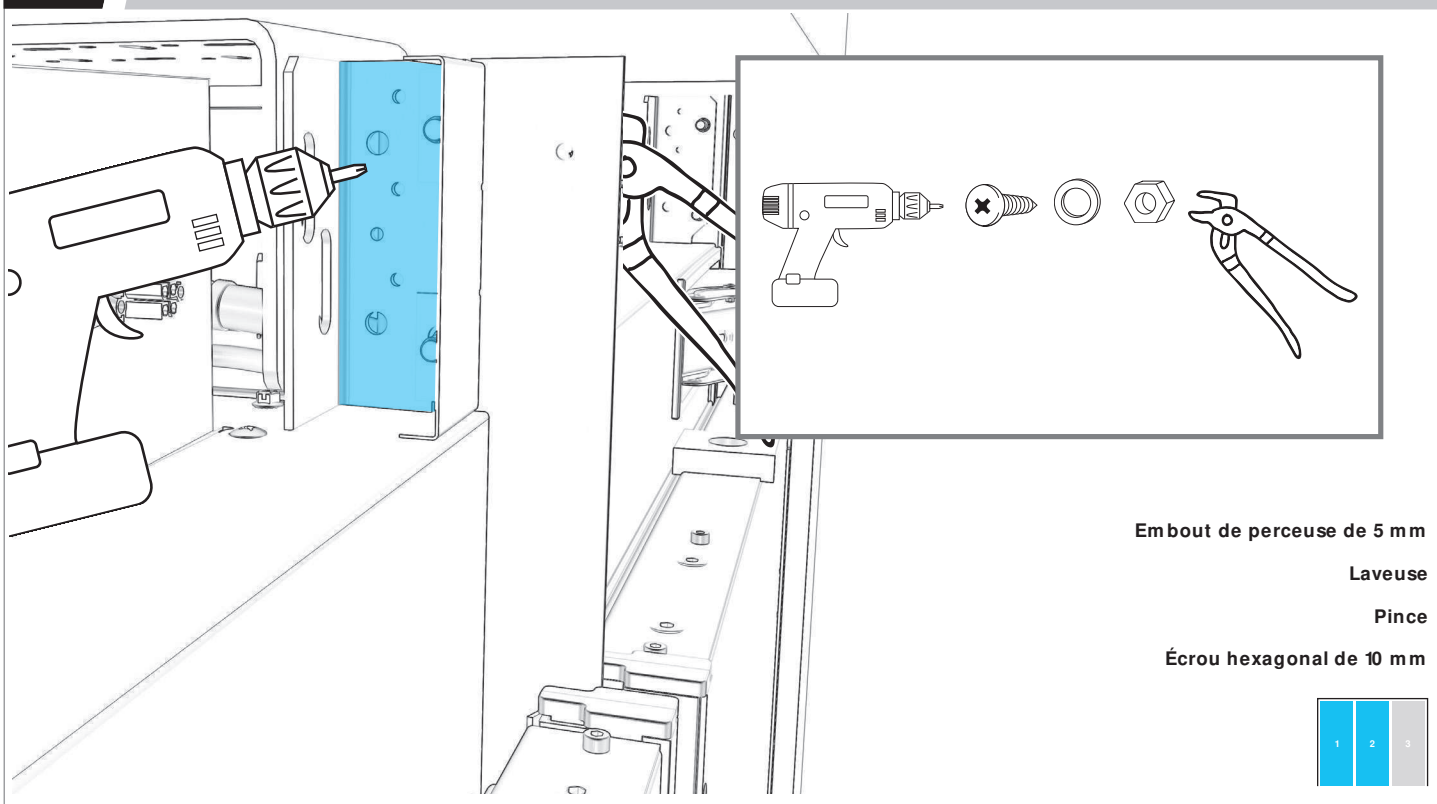

Embout de perceuse de 5 mm

Laveuse

Pince

Écrou hexagonal de 10 mm

8

INSTALLATION DU TROISIÈME APPAREIL

8.10 RÉPÉTER POUR LA BRIDE DU BAS.

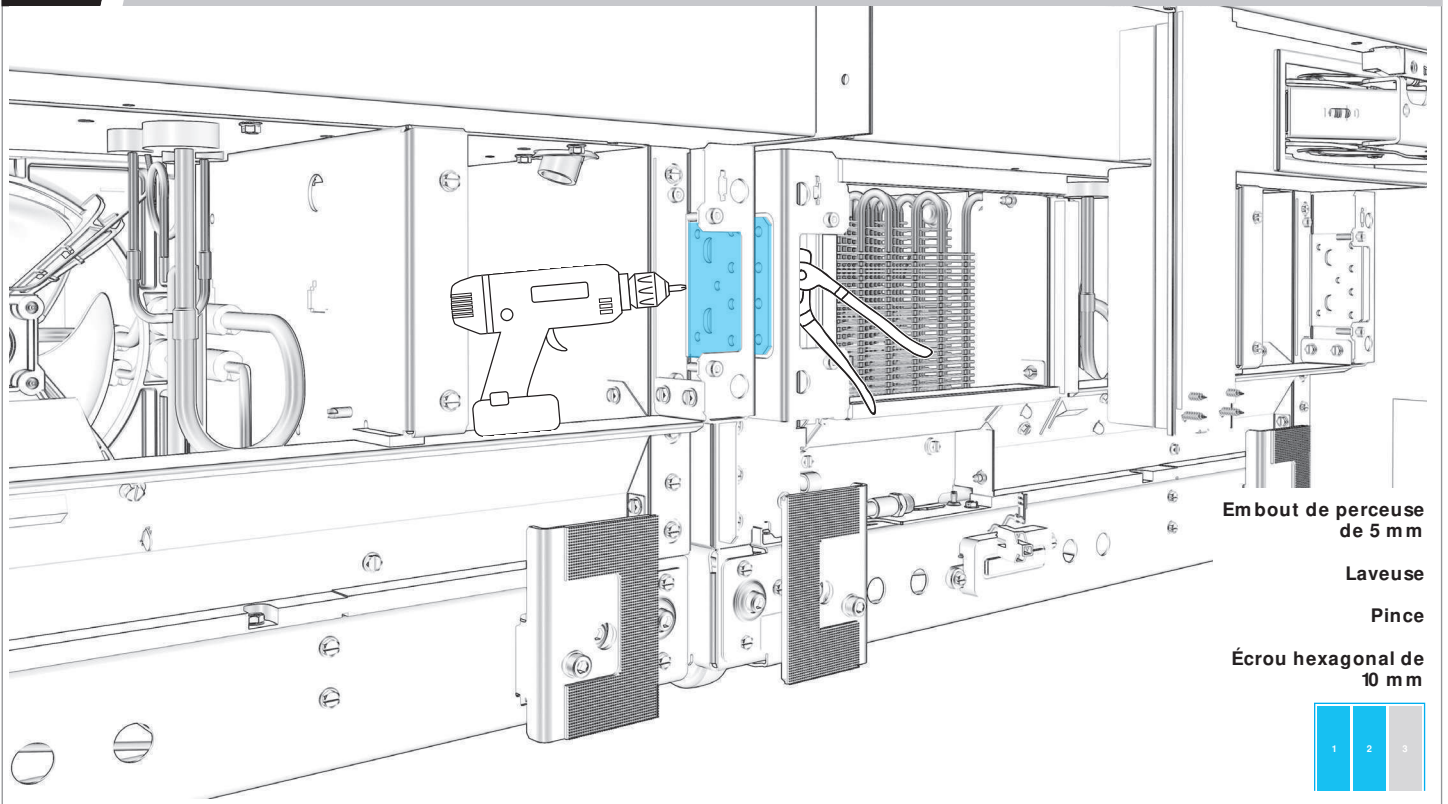

8.11 TROISIÈME APPAREIL : FIXER AU PANNEAU DE DROITE.

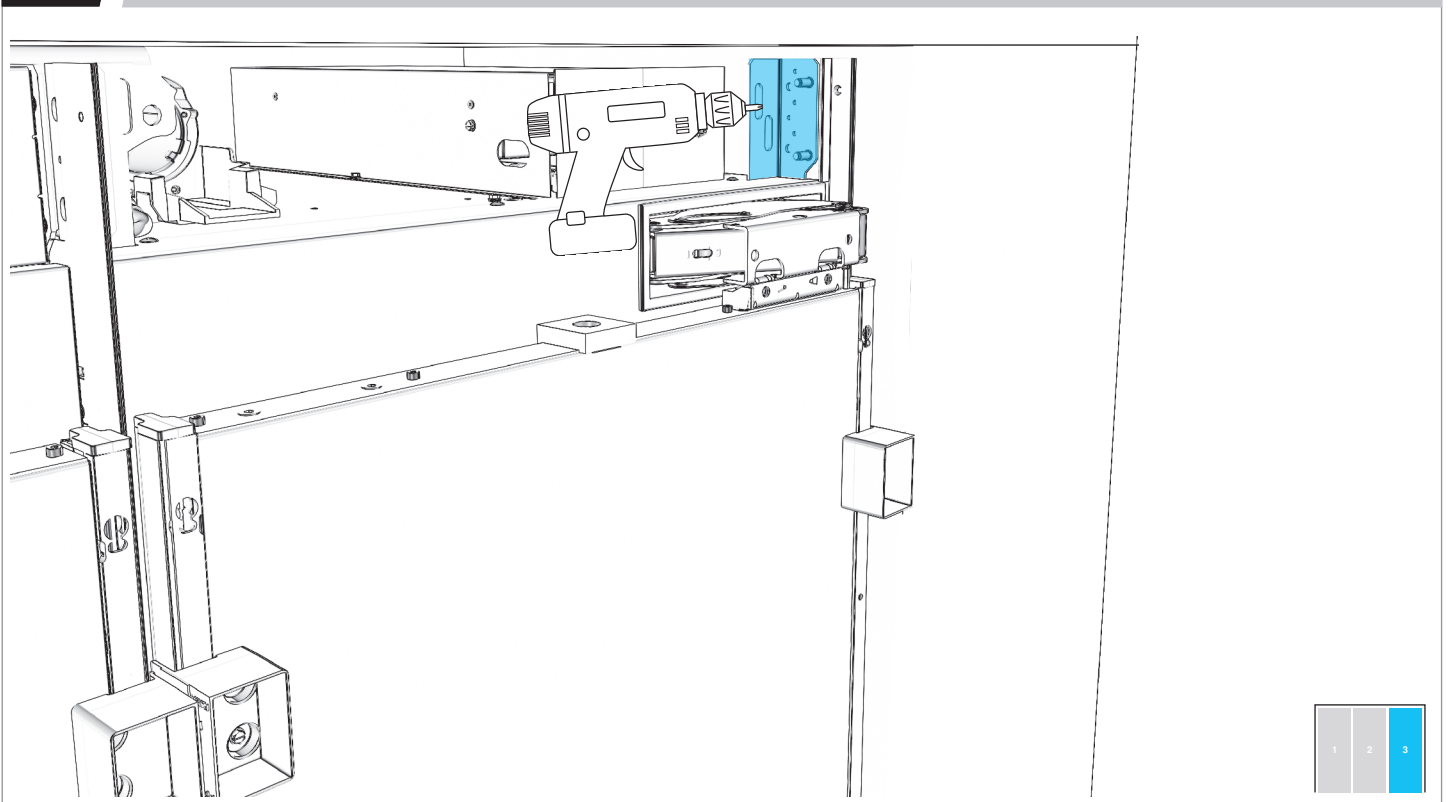

8.12

TROISIÈME APPAREIL : RÉPÉTER POUR LA BRIDE DU BAS.

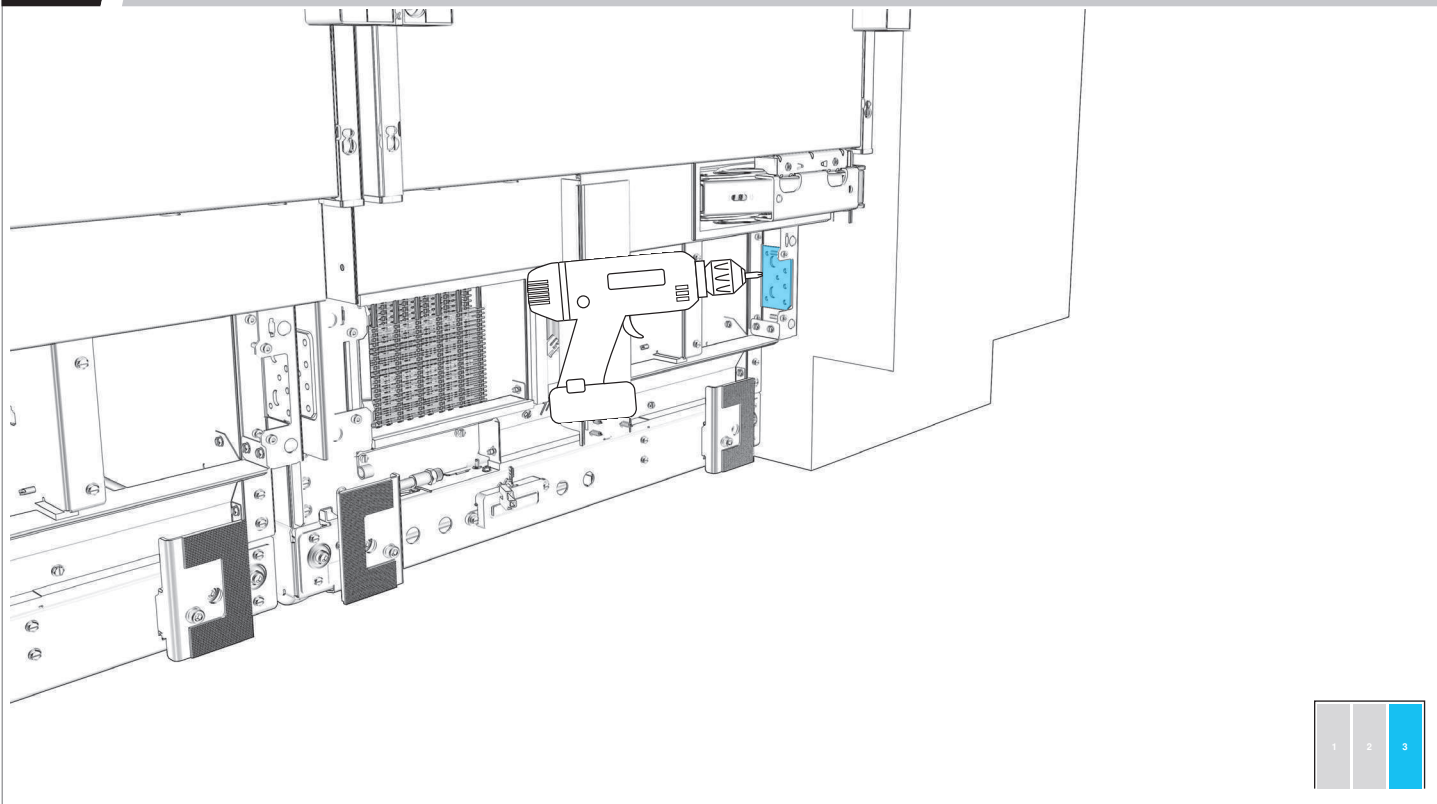

8.13

RACCORDER LE TUYAU D'ARRIVÉE D'EAU.

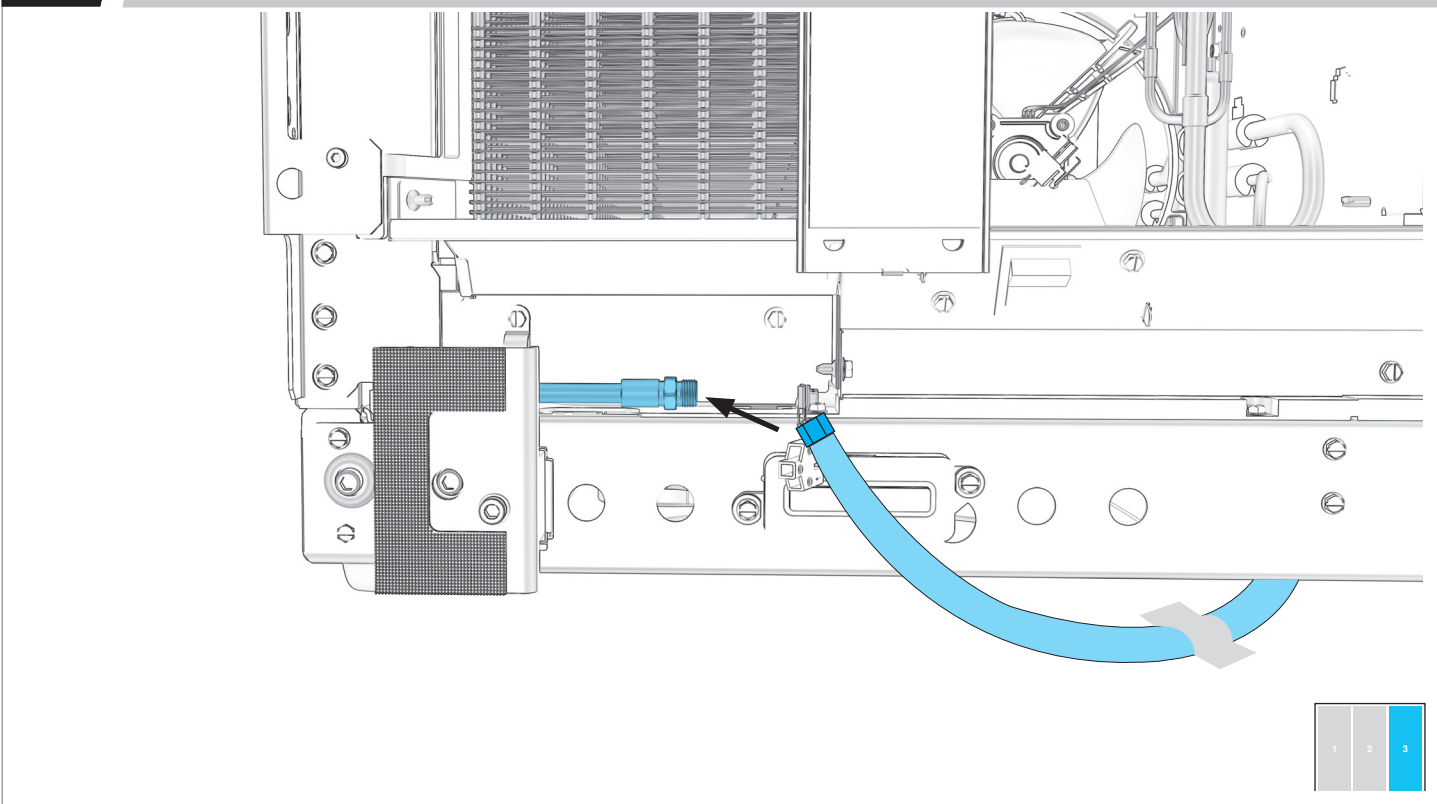

PRÉPARATION

DE L'APPAREIL POUR SON UTILISATION

9.1 POUR CHAQUE APPAREIL : ALIGNER LE BOÎTIER DU FILTRE ENTRE LES BRIDES SITUÉS AU HAUT DE L'APPAREIL.

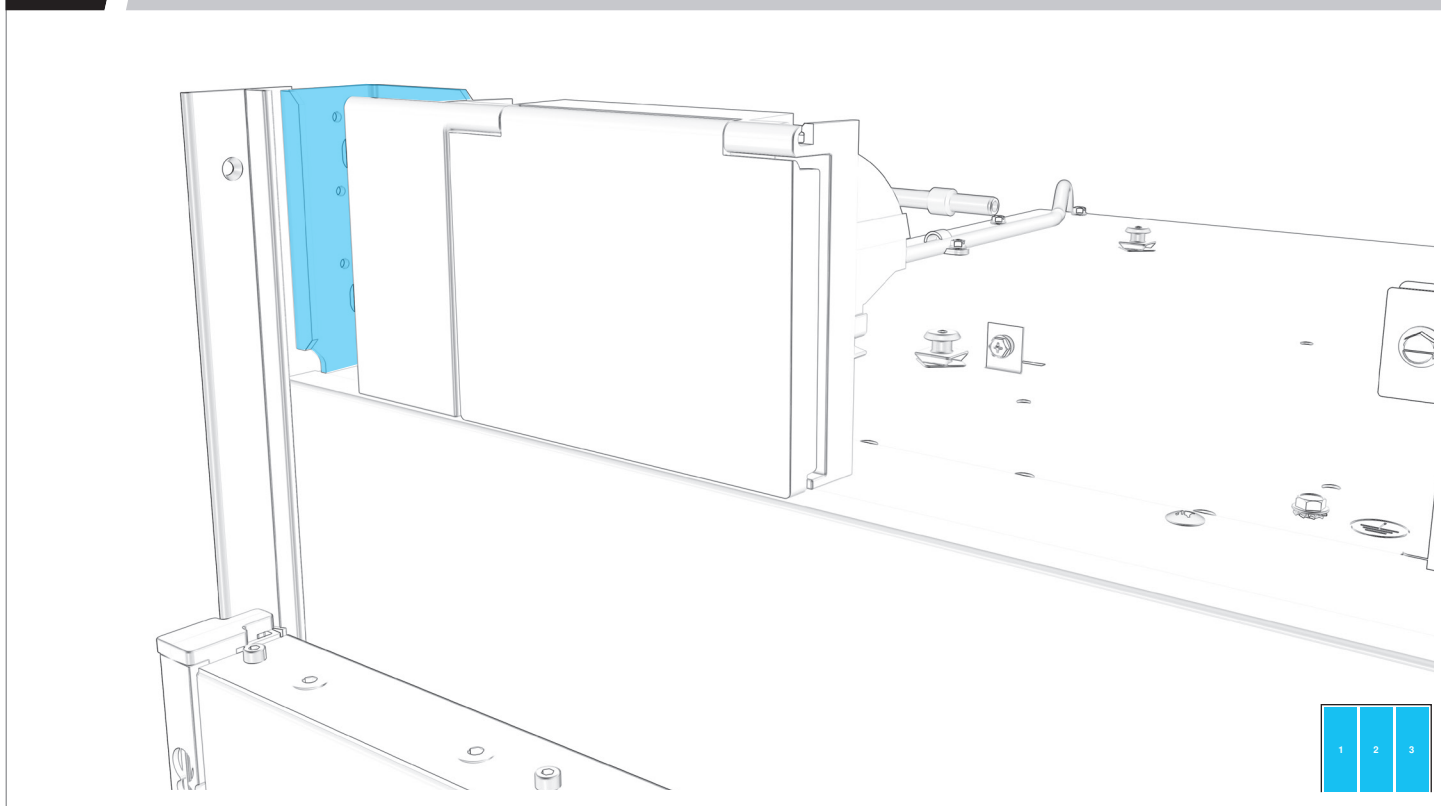

9.2 POUR CHAQUE APPAREIL : INSTALLER DE NOUVEAU LE BOÎTIER EN POUSSANT AVEC FORCE VERS LA GAUCHE.

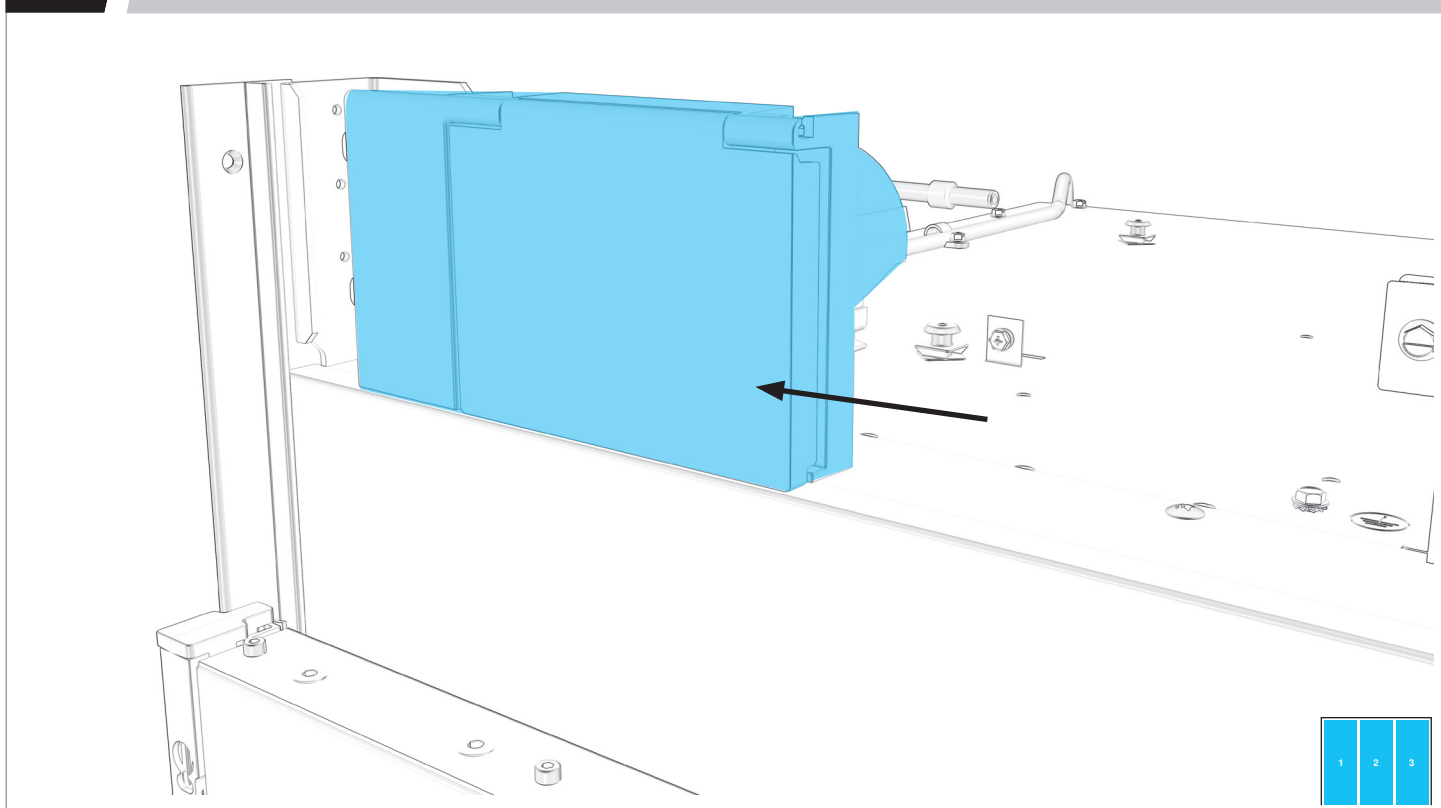

9

PRÉPARATION DE L'APPAREIL POUR SON UTILISATION

9.3

POUR CHAQUE APPAREIL : INSÉRER LE FILTRE À EAU JUSQU'À CE QU'IL SOIT BIEN PLACÉ.

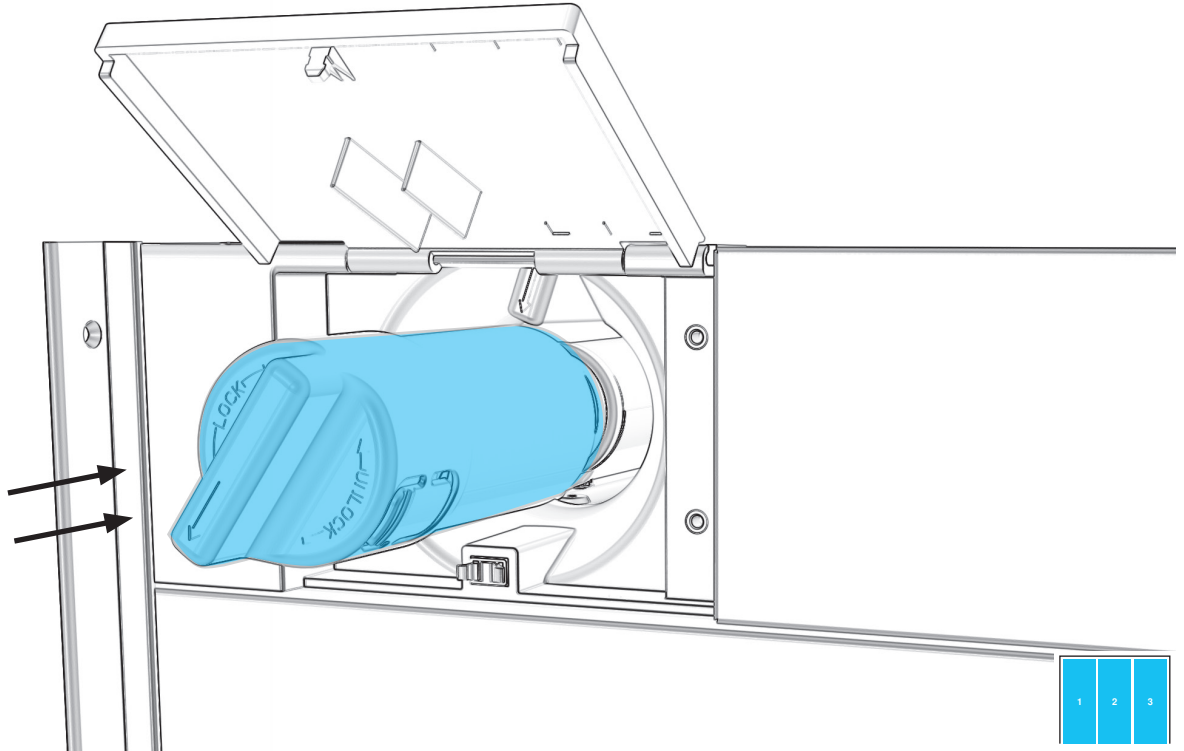

9.4

POUR CHAQUE APPAREIL : FAIRE TOURNER LE FILTRE DANS LE SENS HORAIRE POUR ALIGNER LES FLÈCHES.

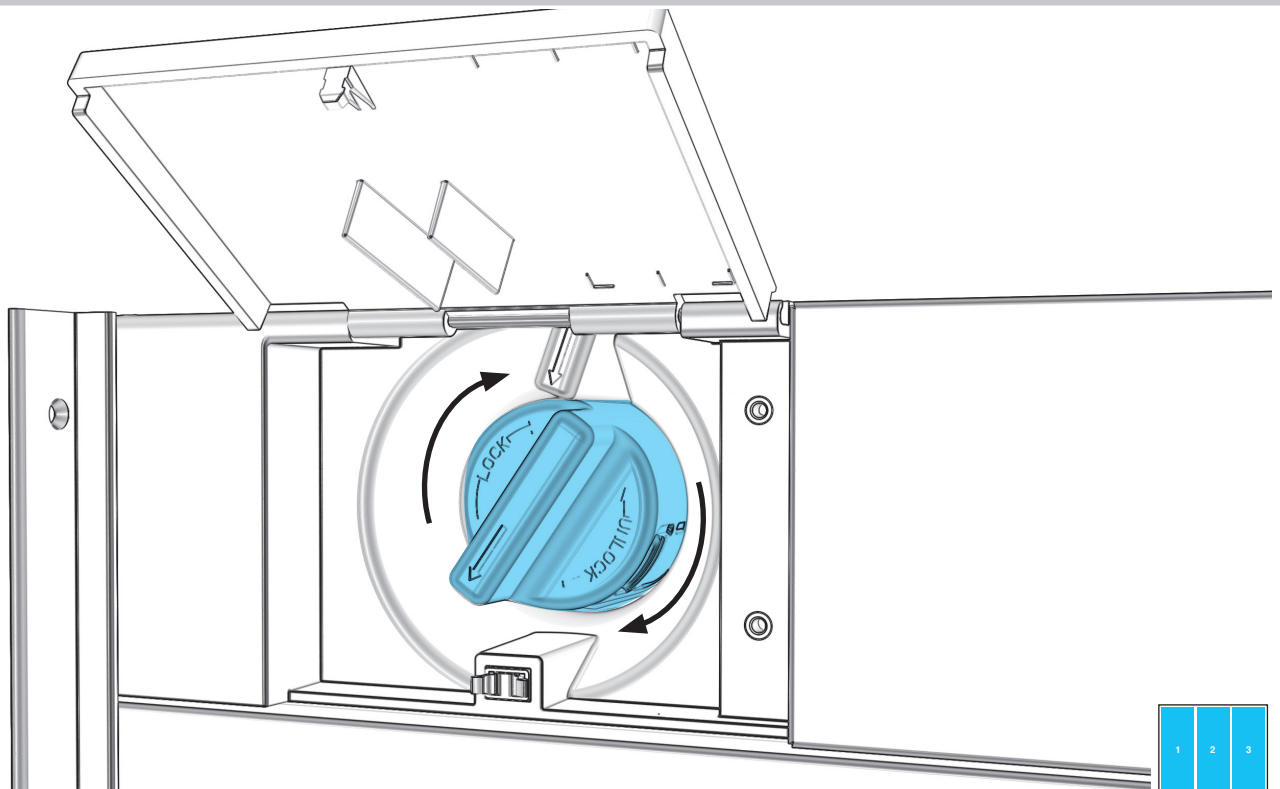

9.5

POUR CHAQUE APPAREIL : FIXER À L'AIDE DE DEUX VIS ET REPLACER LE COUVERCLE.

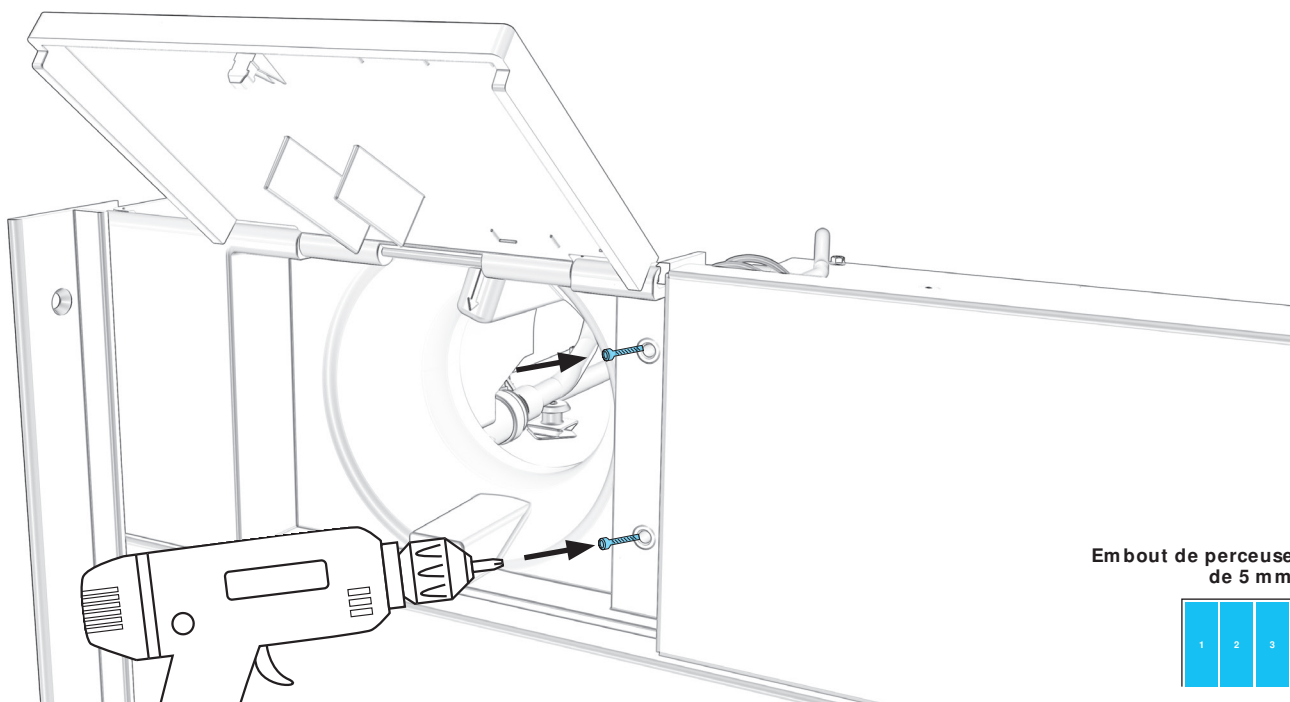

9.6

POUR CHAQUE APPAREIL : RÉINSTALLER LA GRILLE D'AÉRATION.

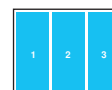
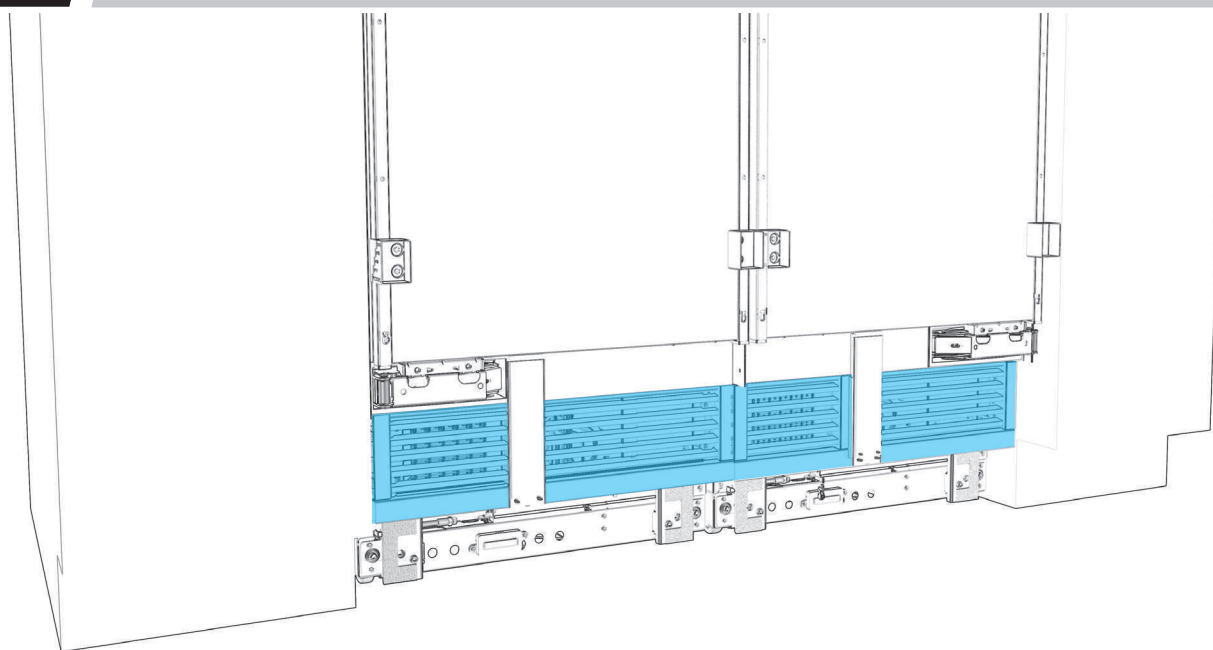

9

PRÉPARATION DE L'APPAREIL POUR SON UTILISATION

9.7

POUR CHAQUE APPAREIL : METTRE L'APPAREIL SOUS TENSION

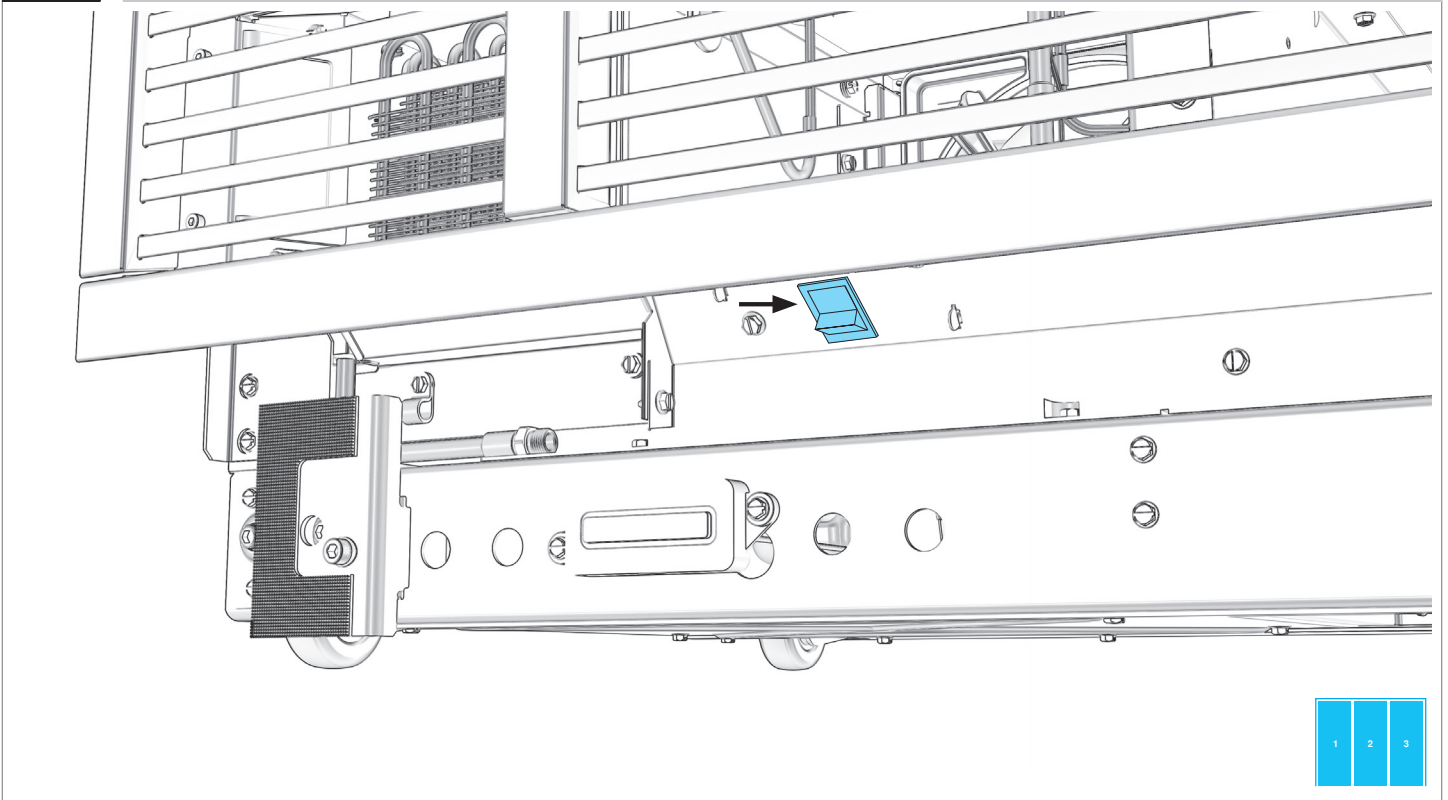

VÉRIFICATION DE L'INSTALLATION

- P.201** PRÉPARATION DE LA PLINTHE
EN BOIS PERSONNALISÉE
- P.204** PRÉPARATION DE LA PLINTHE
EN ACIER INOXYDABLE
- P.207** ALIGNEMENT ET INSTALLATION
DES PLINTHES

PRÉPARATION DE LA
P L I N T H E
EN BOIS PERSONNALISÉE

10.1

MESURER ET MARQUER LA LIGNE CENTRALE DE LA PLINTHE.

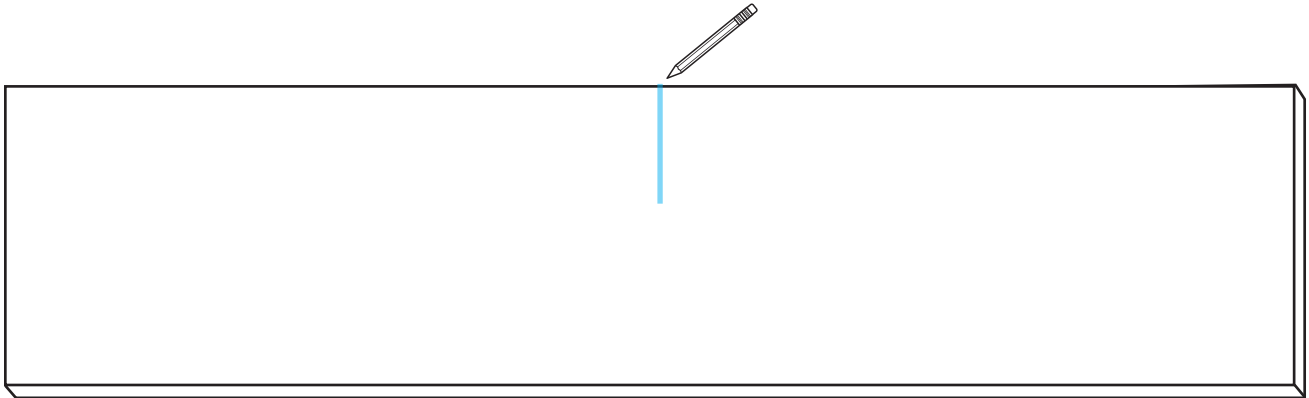

EFFECTUER TOUTES LES ÉTAPES POUR CHAQUE APPAREIL.

10.2

GABARIT D'ALIGNEMENT

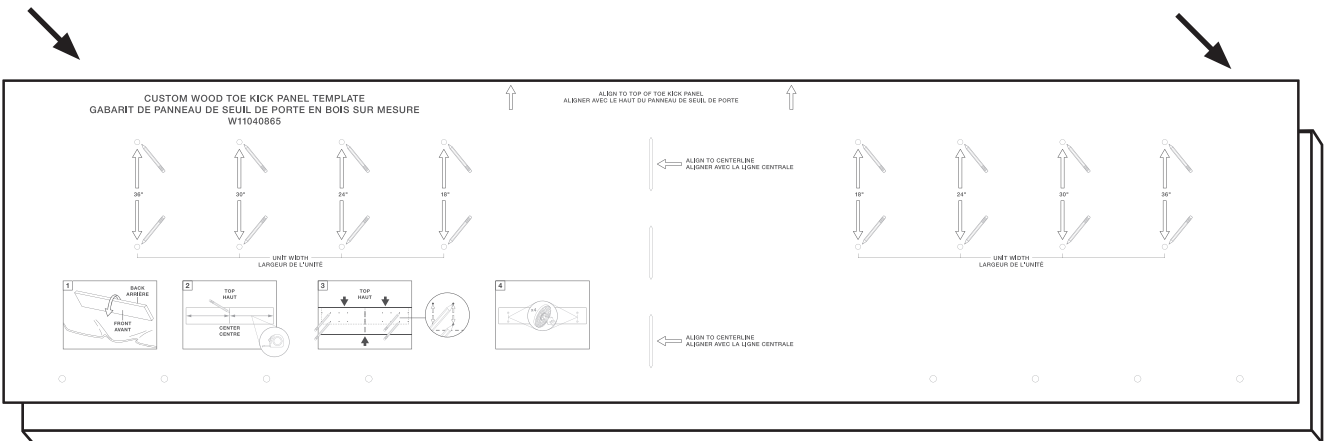

10.3

MARQUE L'EMPLACEMENT DES TAMPONS DE MAINTIEN.

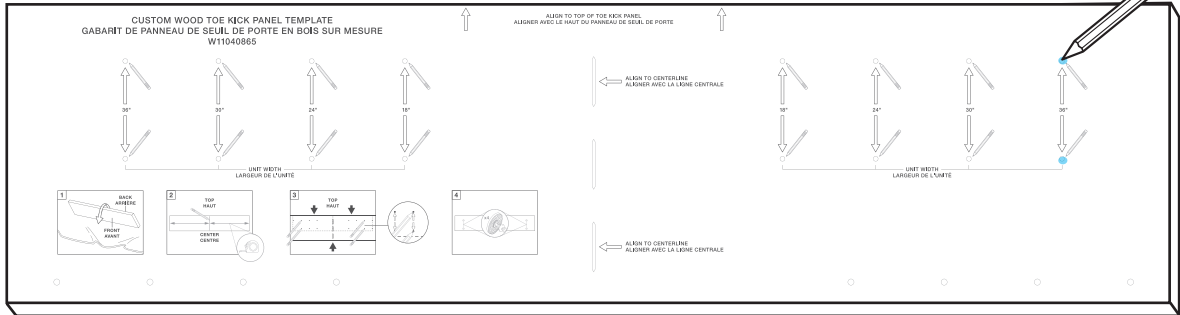

10.5

FIXER LES TAMPONS DE MAINTIEN AUX POINTS.

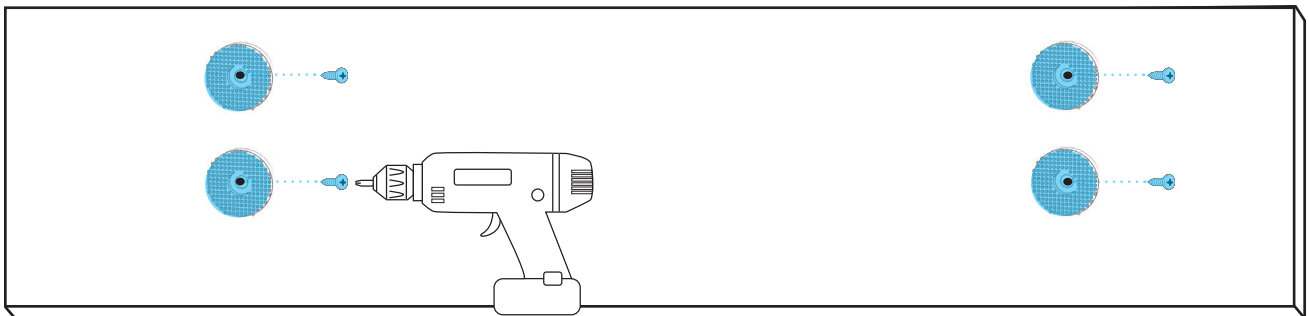

PRÉPARATION DE LA
P L I N T H E
EN ACIER INOXYDABLE

11.1

POUR CHAQUE APPAREIL : DÉVISSER ET JETER LE FAISCEAU DE CÂBLAGE WI FI.

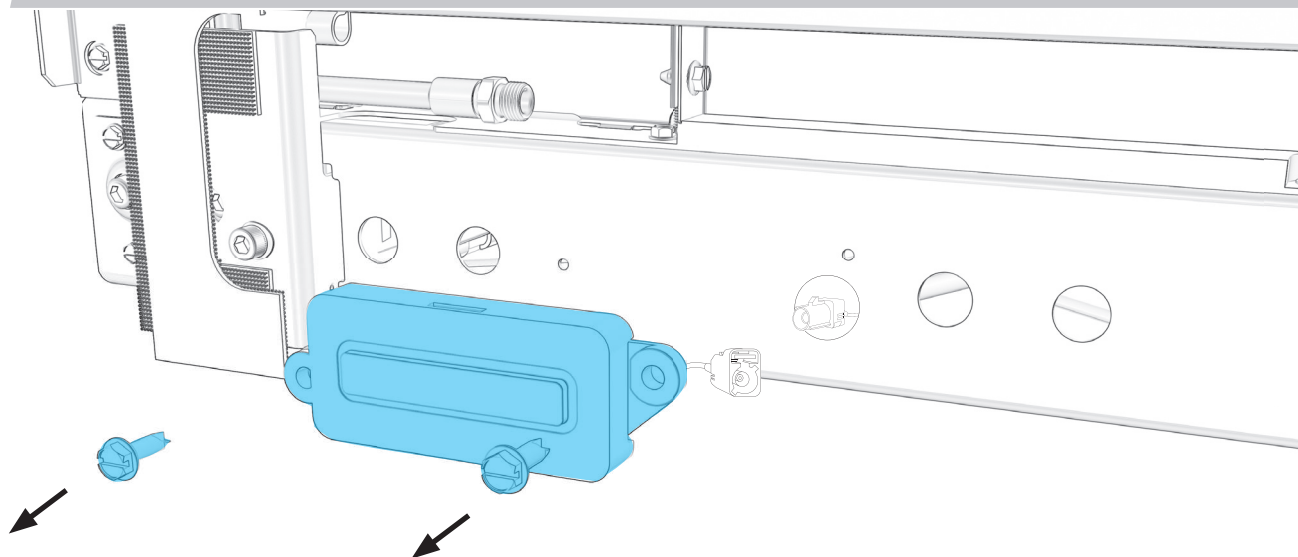

11.2

DÉBRANCHER LE FIL WI FI BLEU DU FAISCEAU DE CÂBLAGE.

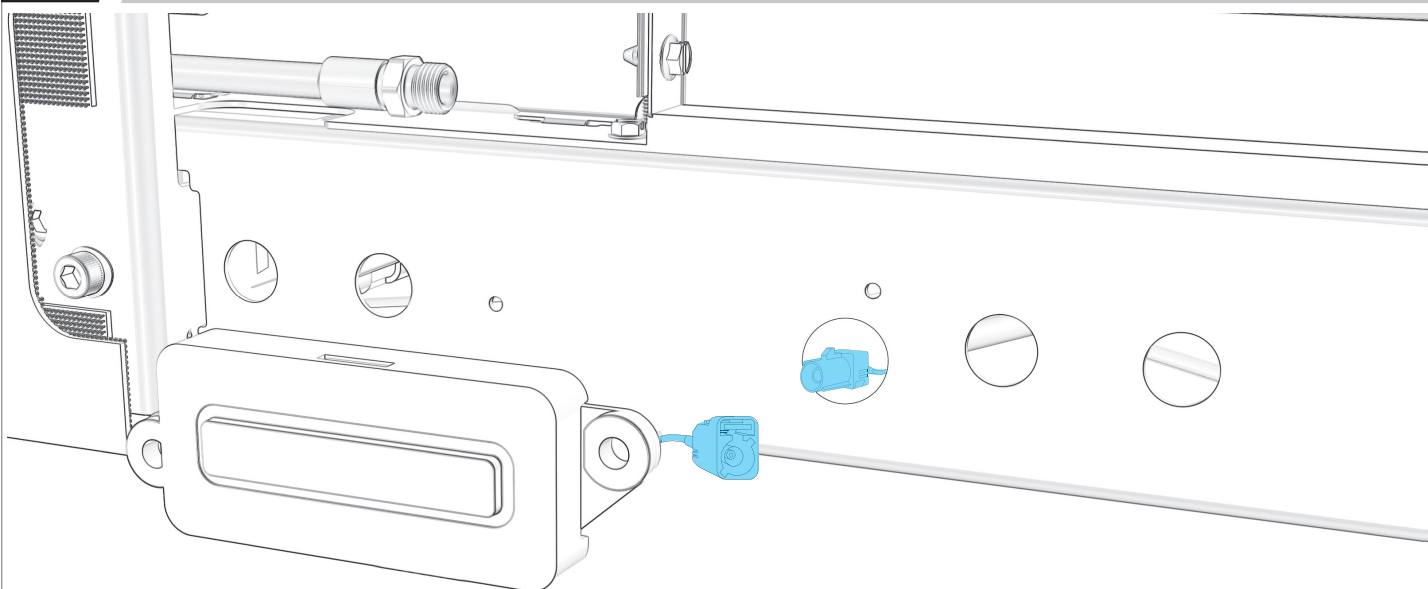

11.3

RELIER LES FILS BLEUS DE LA PLINTHE ET DE L'APPAREIL.

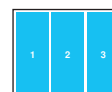
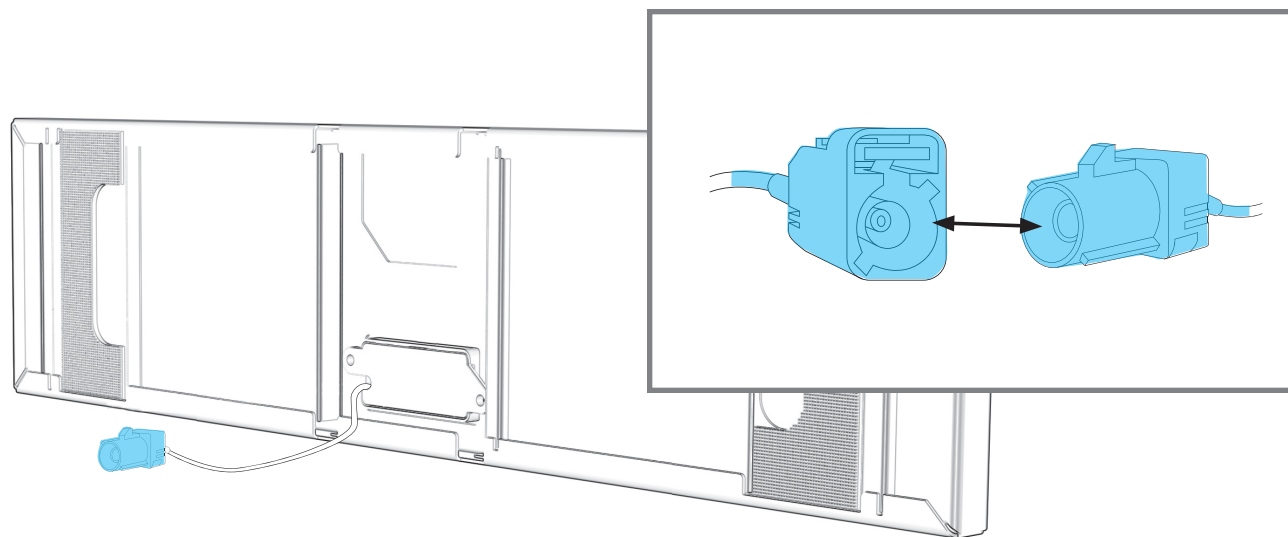

1 2

ALIGNEMENT ET INSTALLATION DE LA
PLINTE

12.1

ALIGNER LES BRIDES DE LA PLINTHE AVEC LA PLINTHE DU MEUBLE.

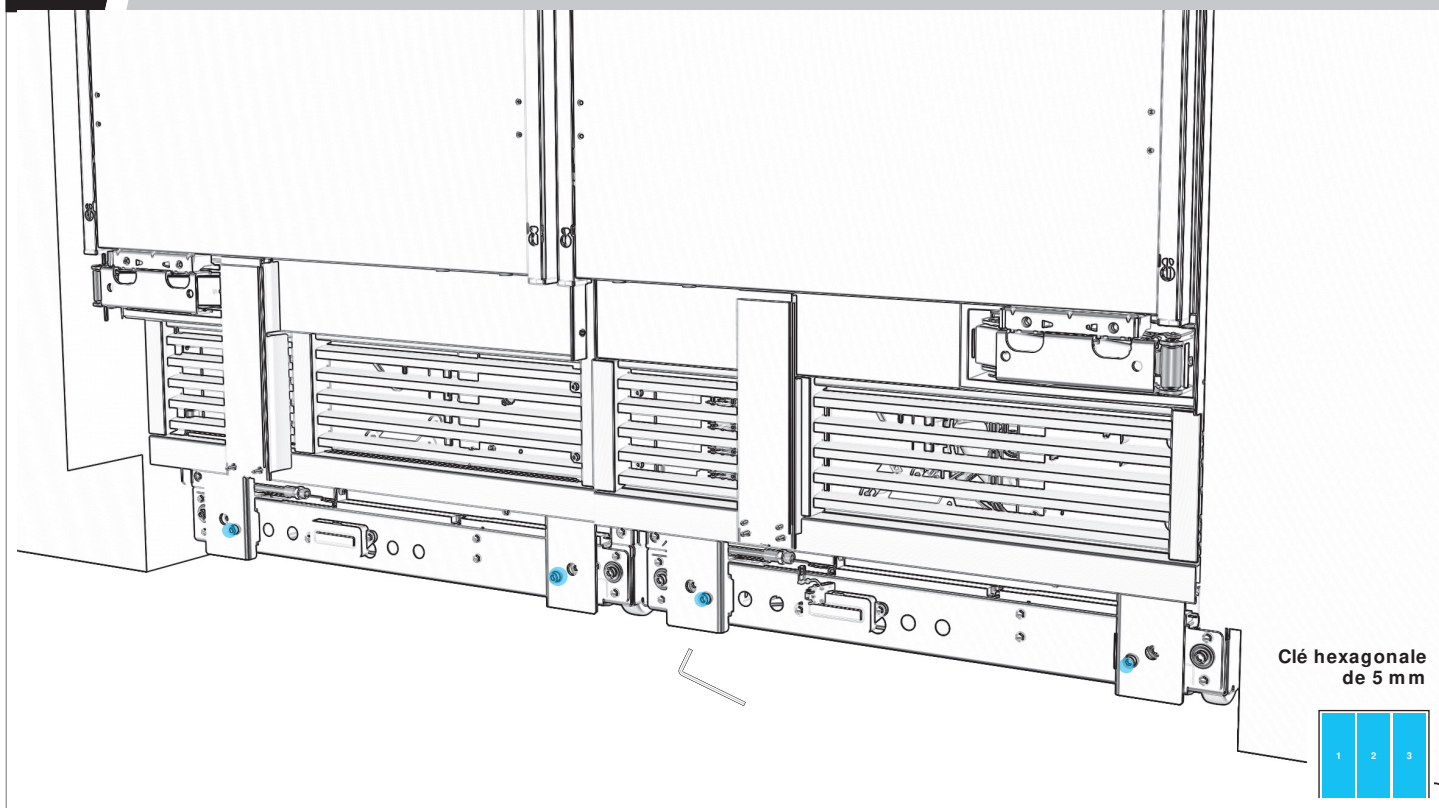

12.2

VÉRIFIER QUE LES BRIDES SONT TOUTES ALIGNÉES.

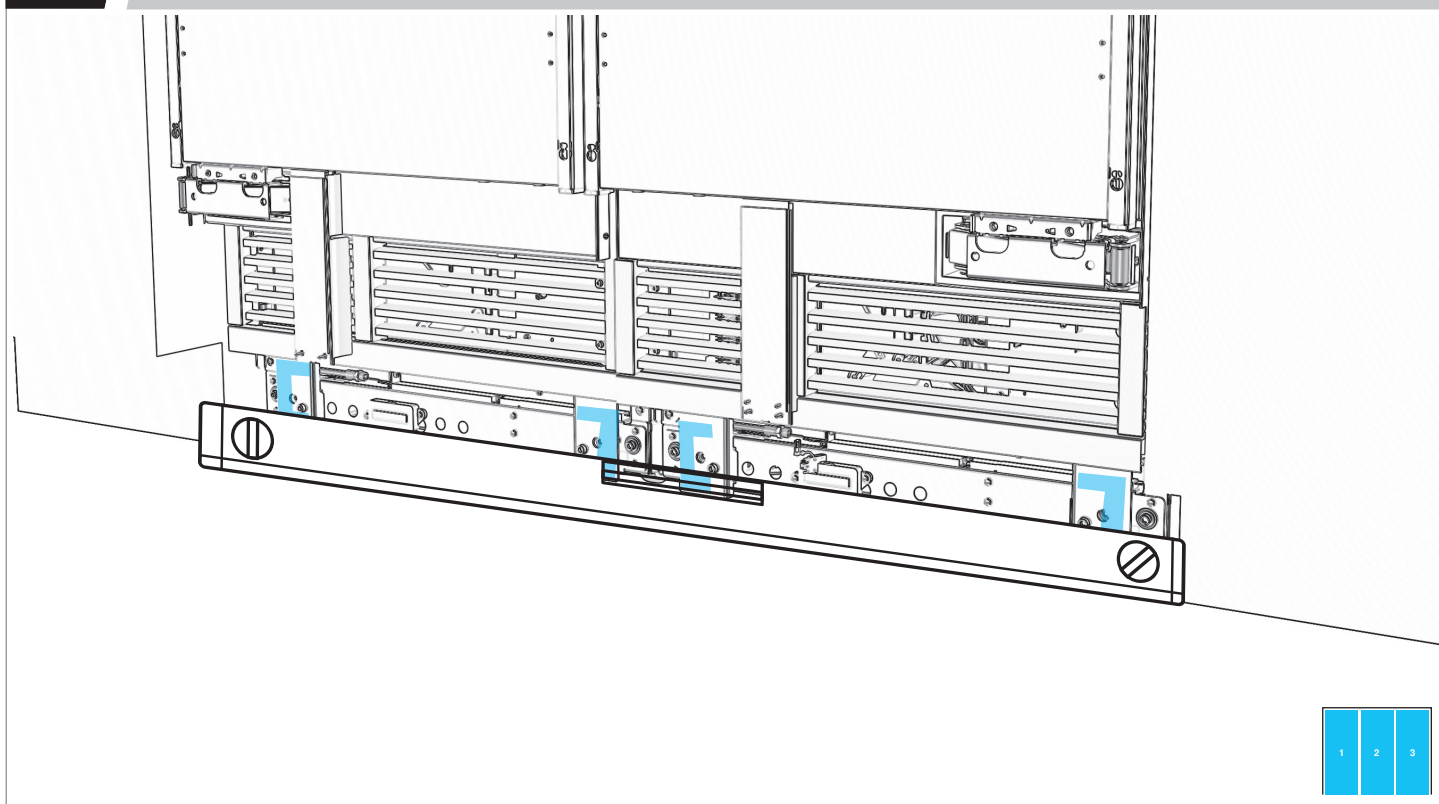

12.3

ALIGNER LES TAMPONS DE MAINTIEN DE LA PLINTHE AVEC LES BRIDES.

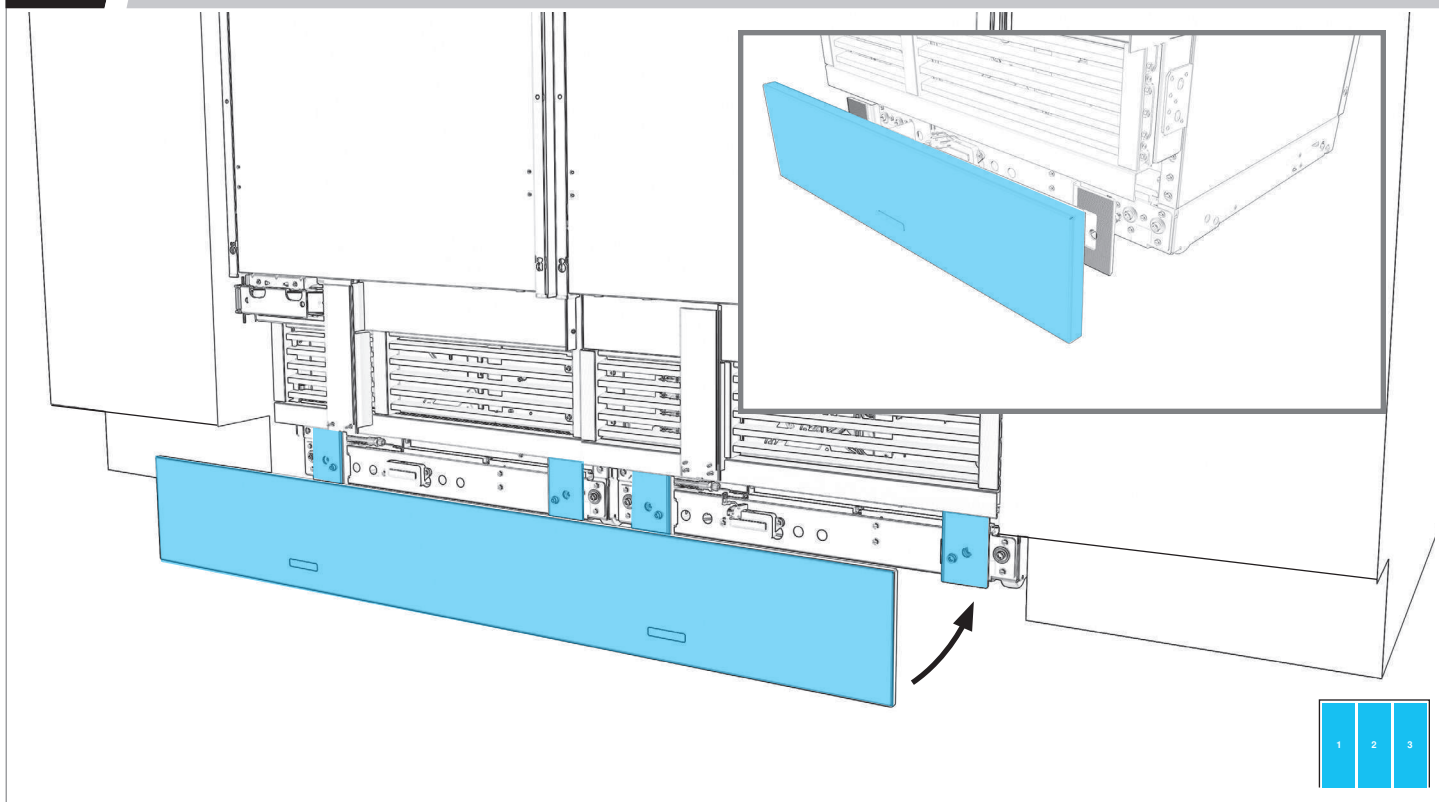

12.4

PRESSER FERMEMENT POUR FIXER.

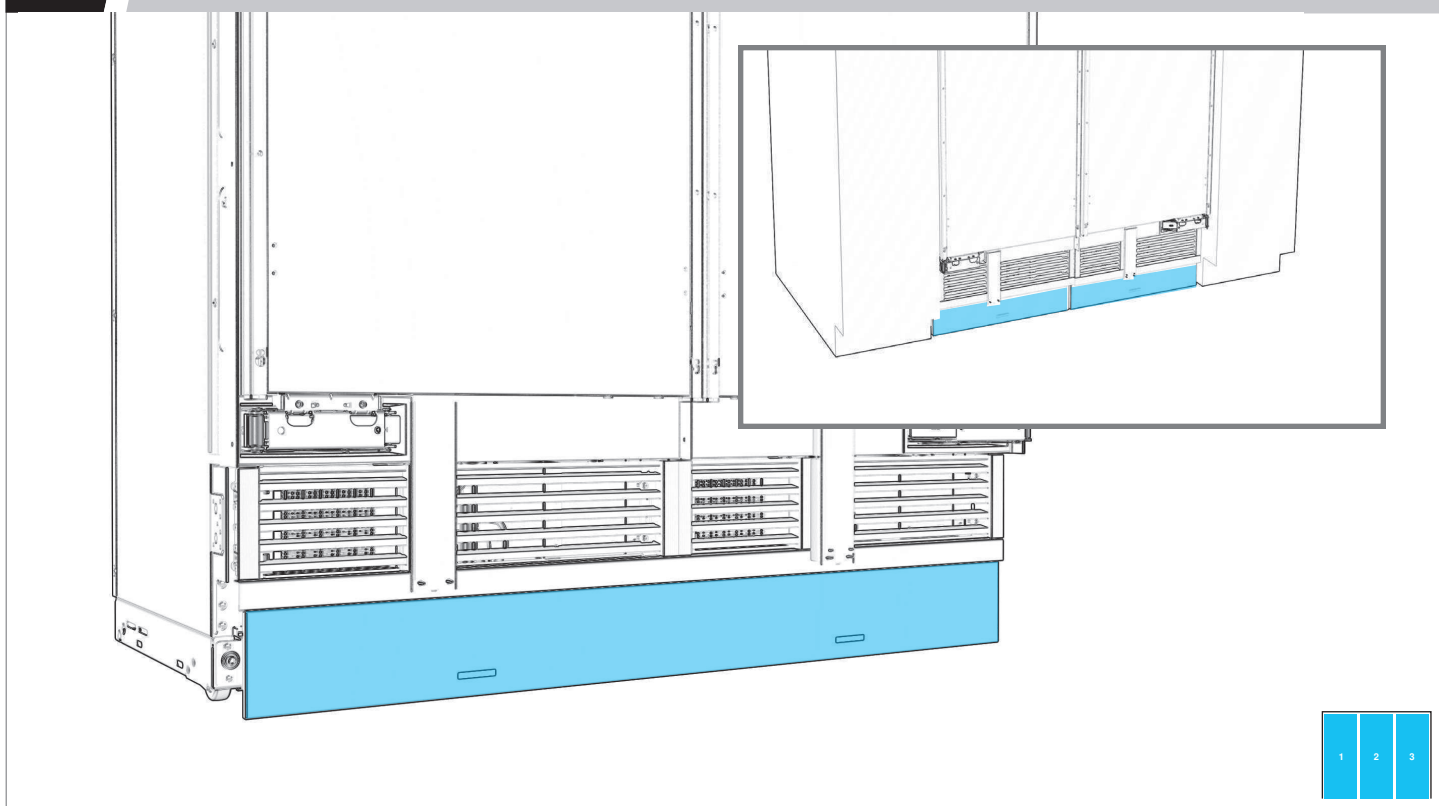

12.5

MESURER L'ÉCART. S'IL Y A UN ÉCART, ENLEVER LA PLINTHE.

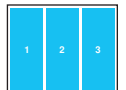
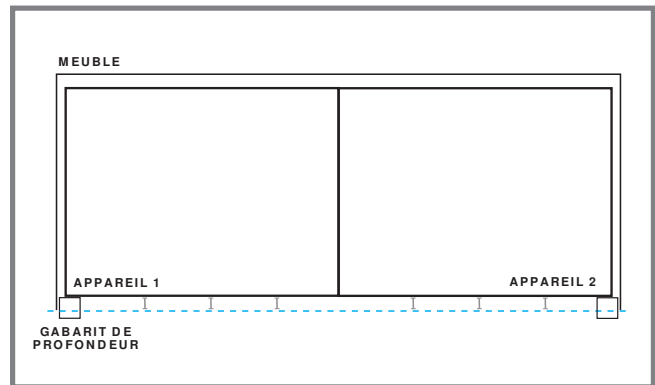
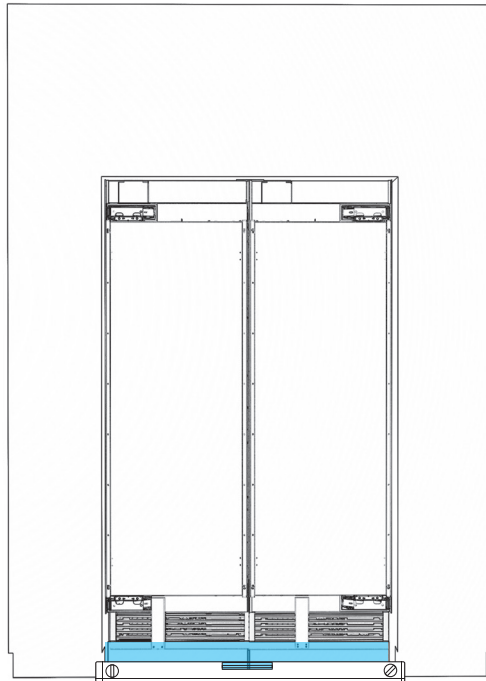

12.6

AJUSTER LES BRIDES POUR ALIGNER LA PLINTHE.

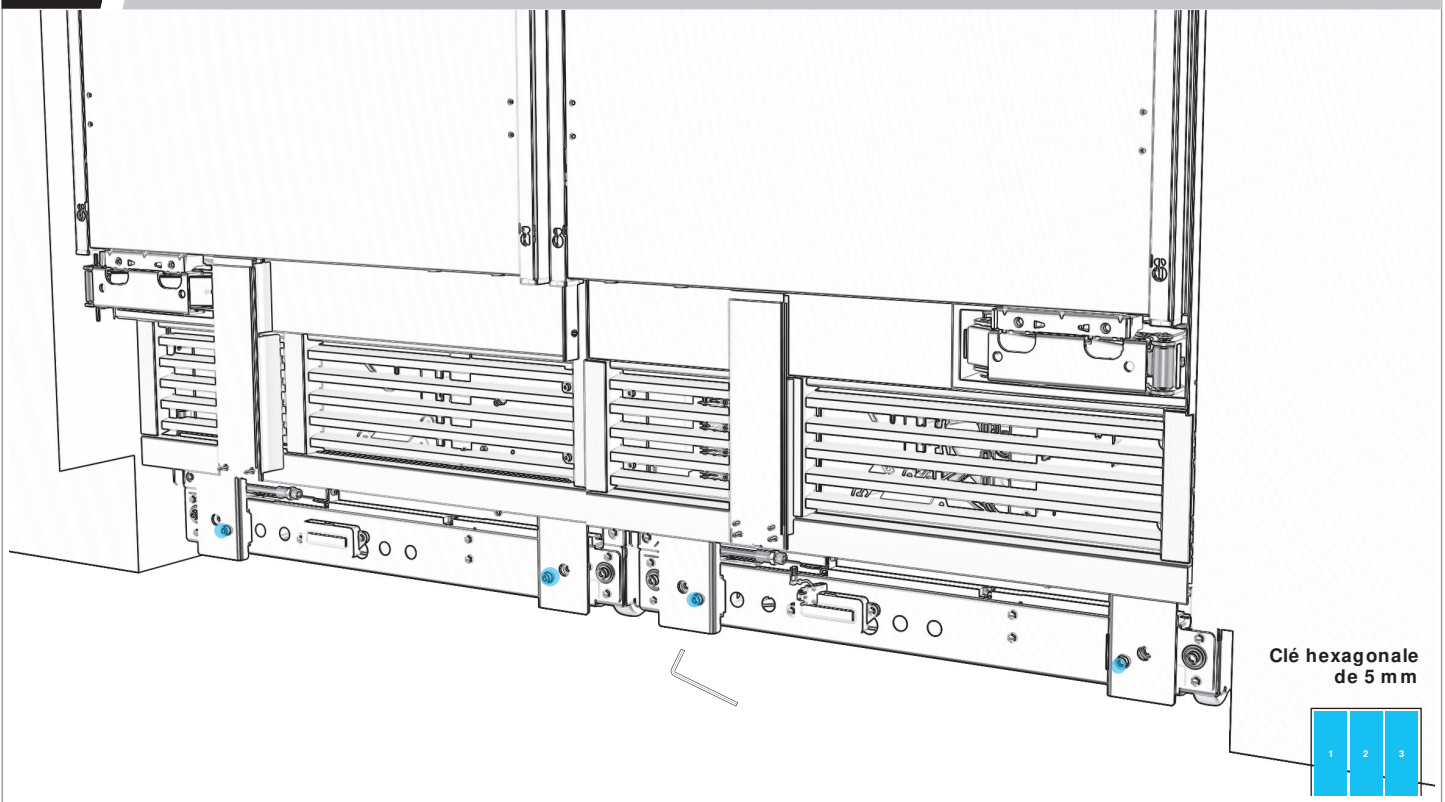

12.7

CONFIRMER L'ALIGNEMENT ET RÉALIGNER AU BESOIN.

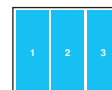
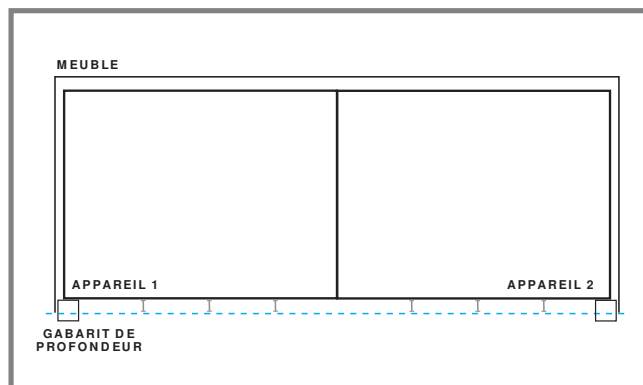
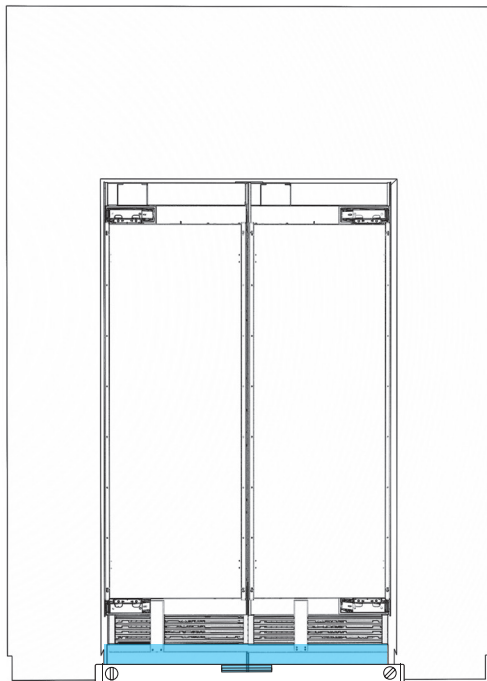

PRÉPARATION DU
PANNEAU
DE BOIS PERSONNALISÉ

13

PRÉPARATION DU PANNEAU DE BOIS PERSONNALISÉ

13.1

RETIRER LE RUBAN POUR FAIRE SORTIR LA GARNITURE DE BRIDE.

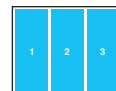
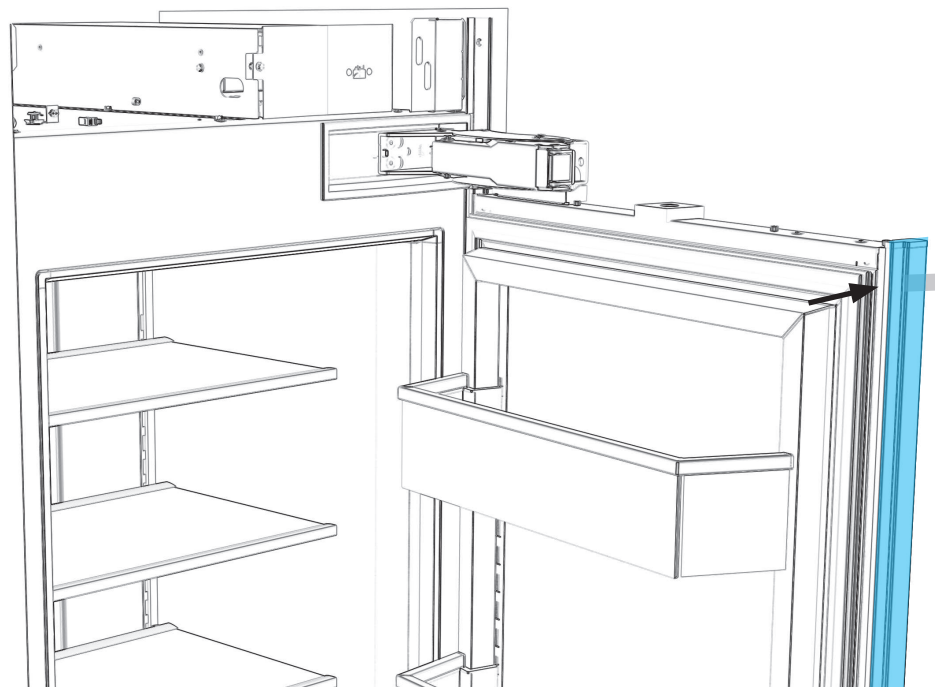

EFFECTUER TOUTES LES ÉTAPES POUR CHAQUE APPAREIL.

13.2

PLACER LE PANNEAU FACE VERS LE BAS.

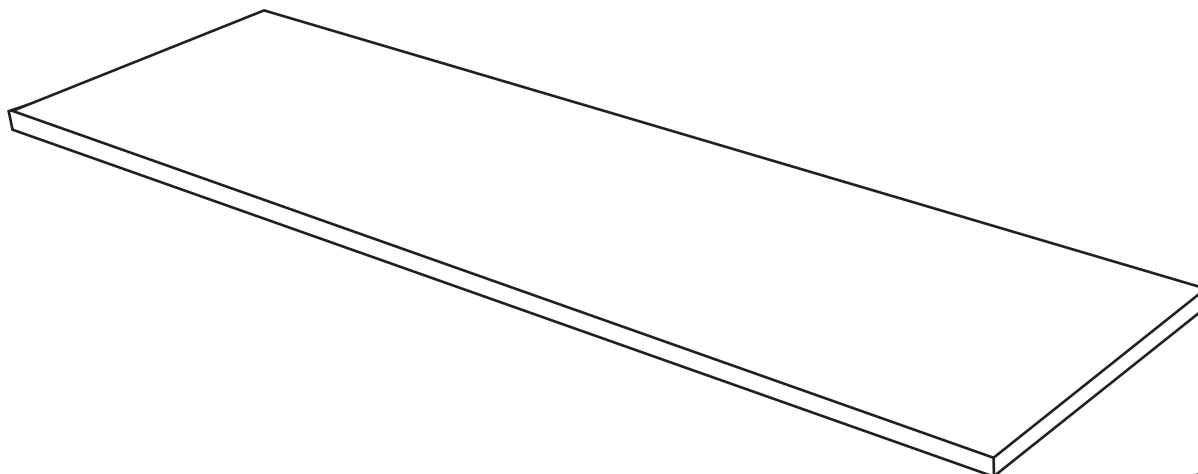

PLACER SUR UNE SURFACE PLANE ET COUVERTE.

13.3

MESURER ET MARQUER LE CENTRE DU PANNEAU.

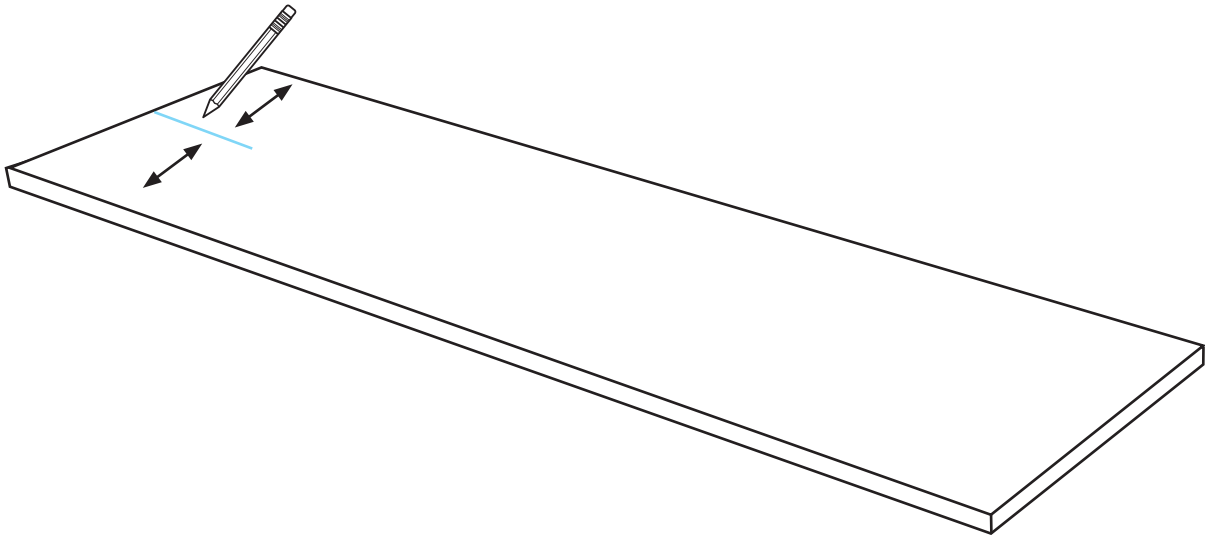

13.4

MARQUE LES TROUS GAUCHE ET DROIT.

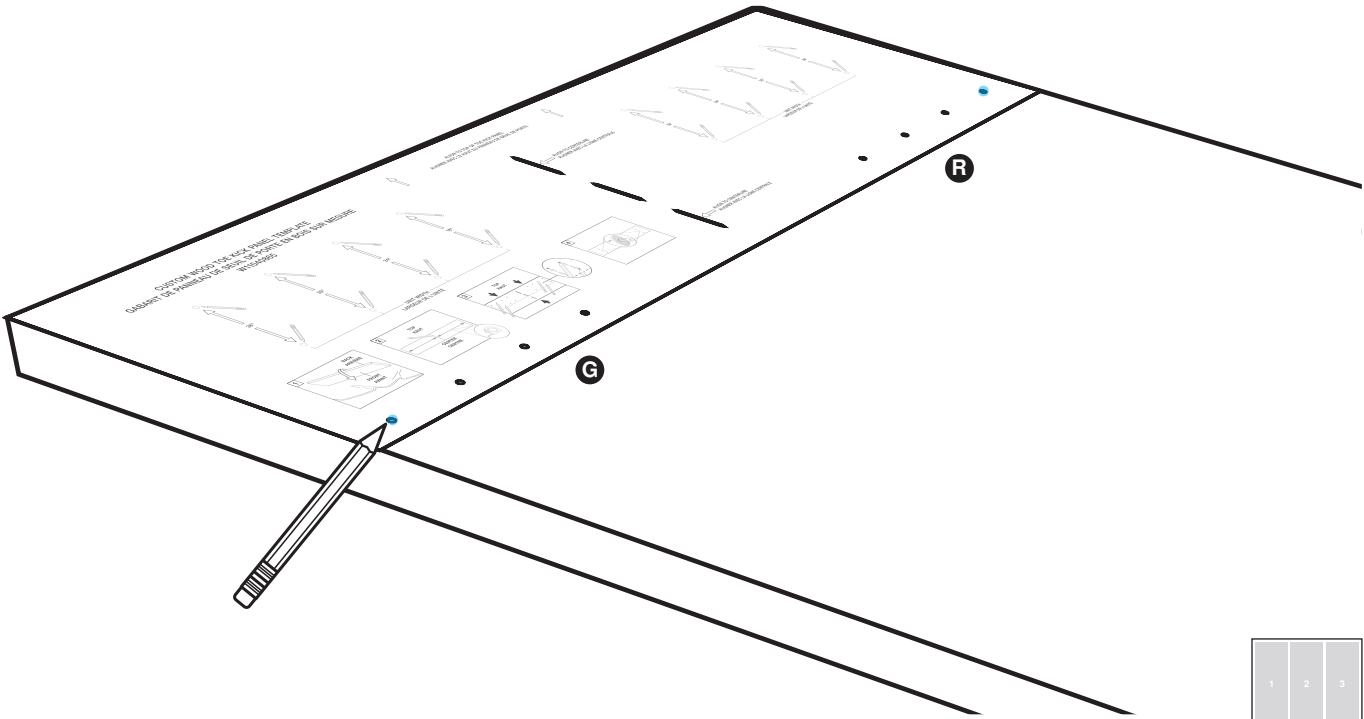

13

PRÉPARATION DU PANNEAU DE BOIS PERSONNALISÉ

13.5

PERCER LES TROUS.

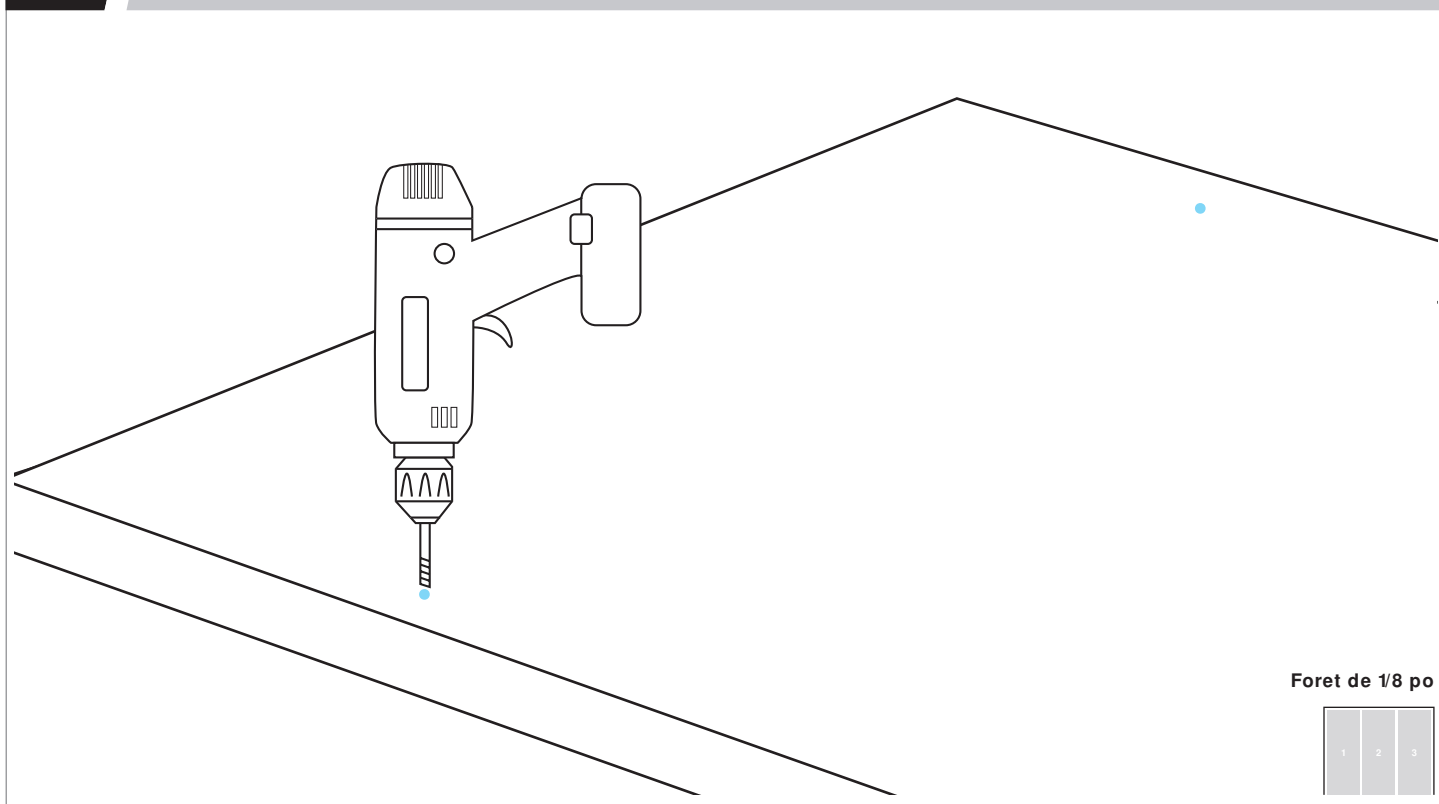

13.6

PLACER DES ATTACHES DANS LES TROUS PRÉPERCÉS.

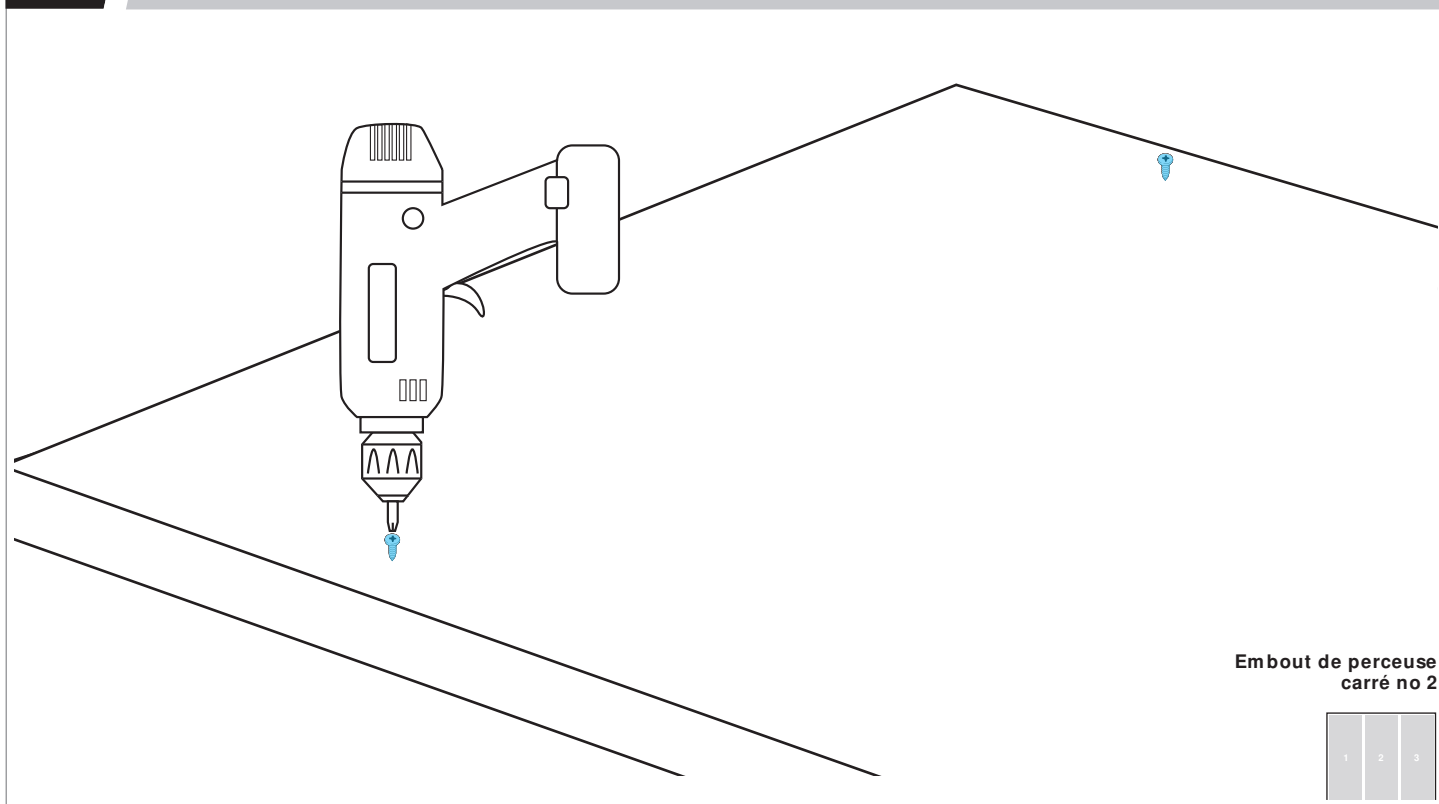

13.7

S'ASSURER QU'IL Y A UN ESPACE DE 18 PO 3,2 MM .

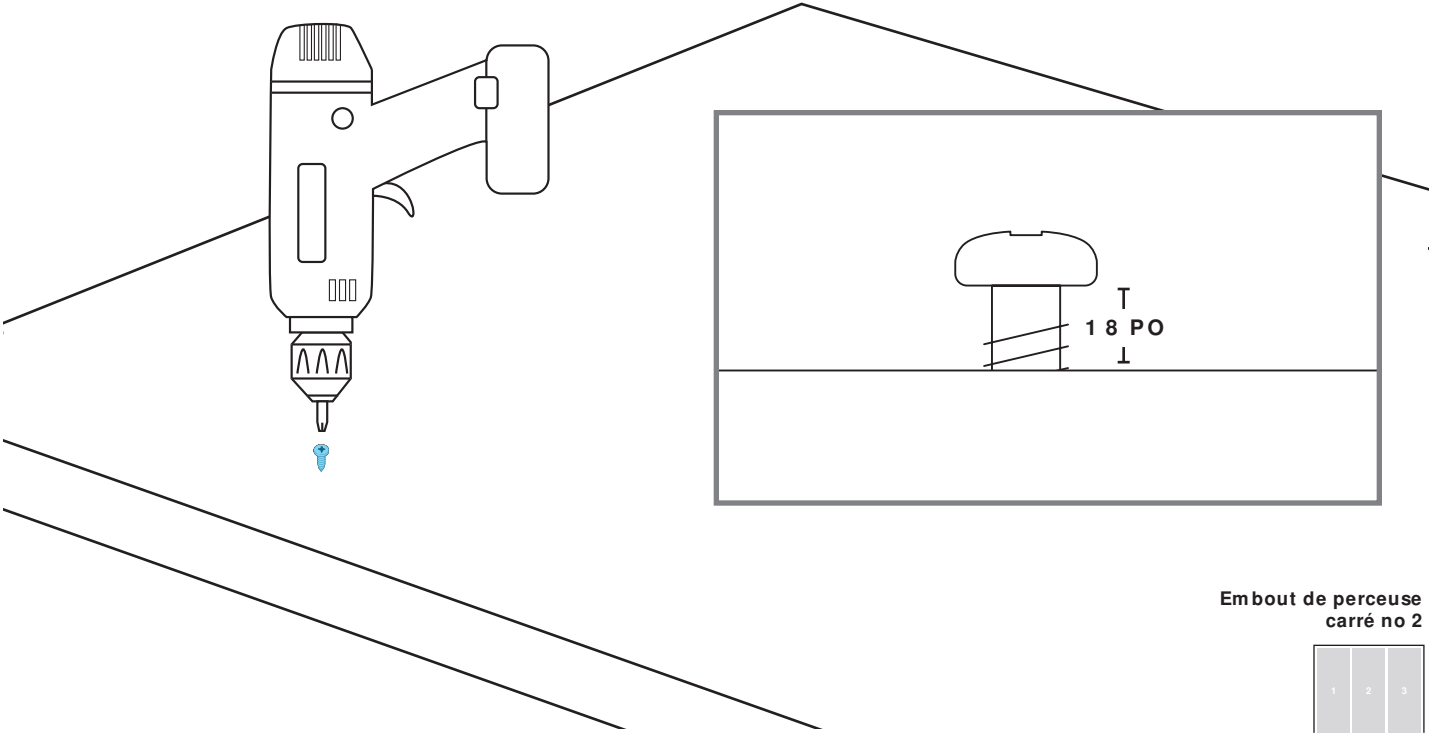

Embout de perceuse
carré no 2



PRÉPARATION DU
P A N N E A U
EN ACIER INOXYDABLE

14.1

RETIRER LE RUBAN POUR FAIRE SORTIR LA GARNITURE DE BRIDE.

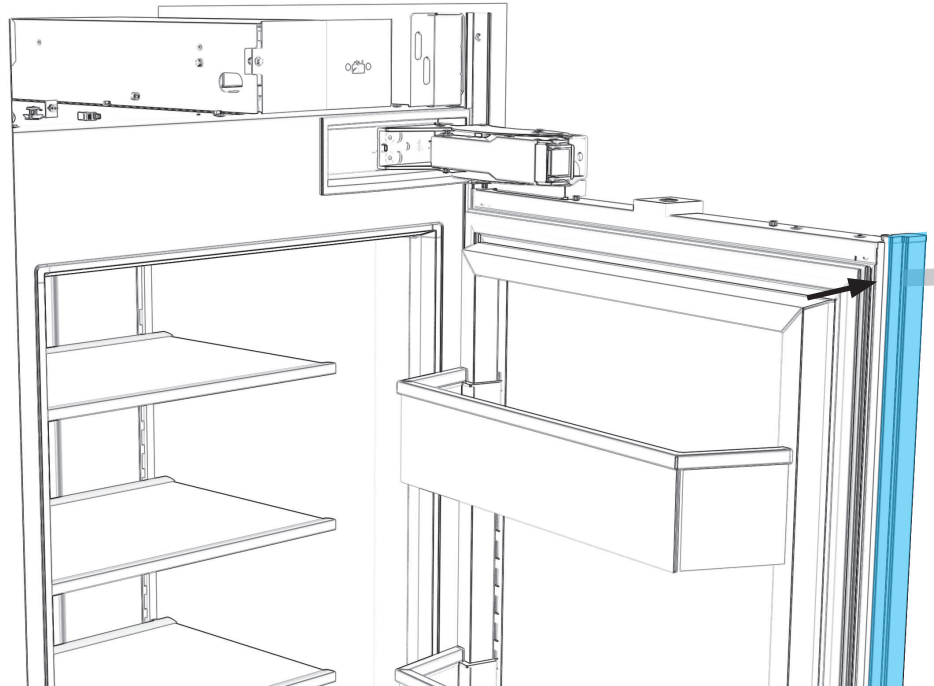

EFFECTUER TOUTES LES ÉTAPES POUR CHAQUE APPAREIL.

14.2

PLACER LE PANNEAU FACE VERS LE BAS.

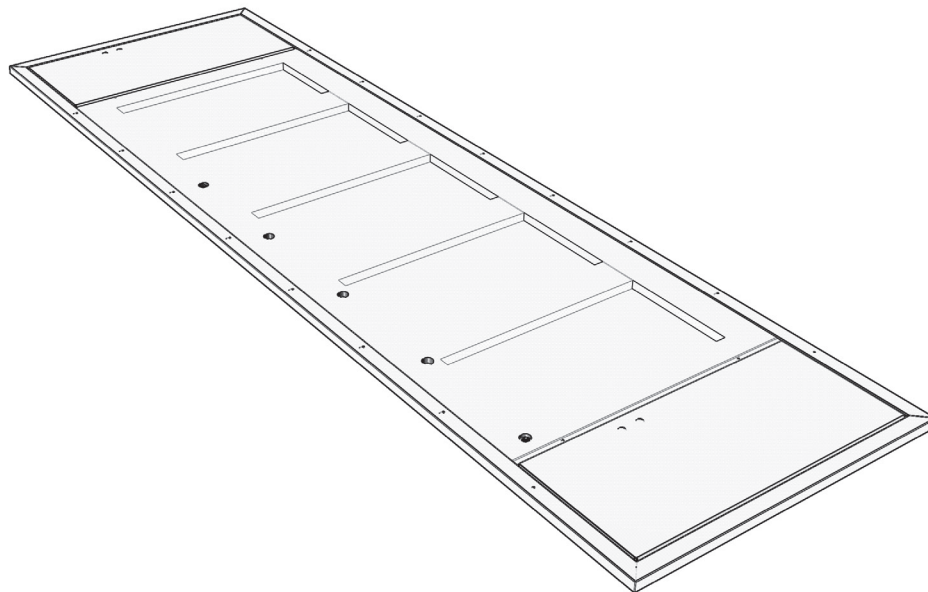

PLACER SUR UNE SURFACE PLANE ET COUVERTE

14

PRÉPARATION DU PANNEAU EN ACIER INOXYDABLE

14.3

PLACER DES ATTACHES DANS LES TROUS PRÉPERCÉS.

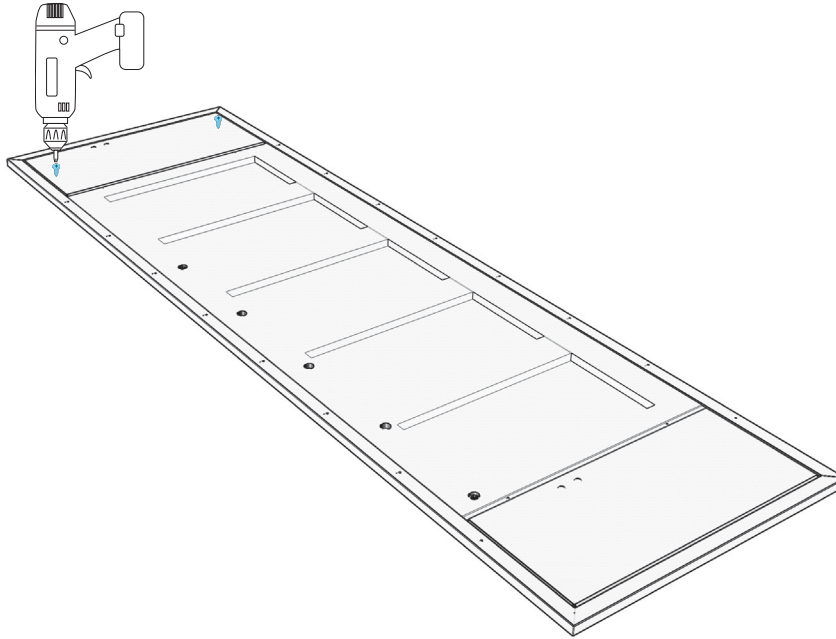

Embout de perceuse
carré no 2



14.4

S'ASSURER QU'IL Y A UN ESPACE DE 18 PO 3,2 MM .

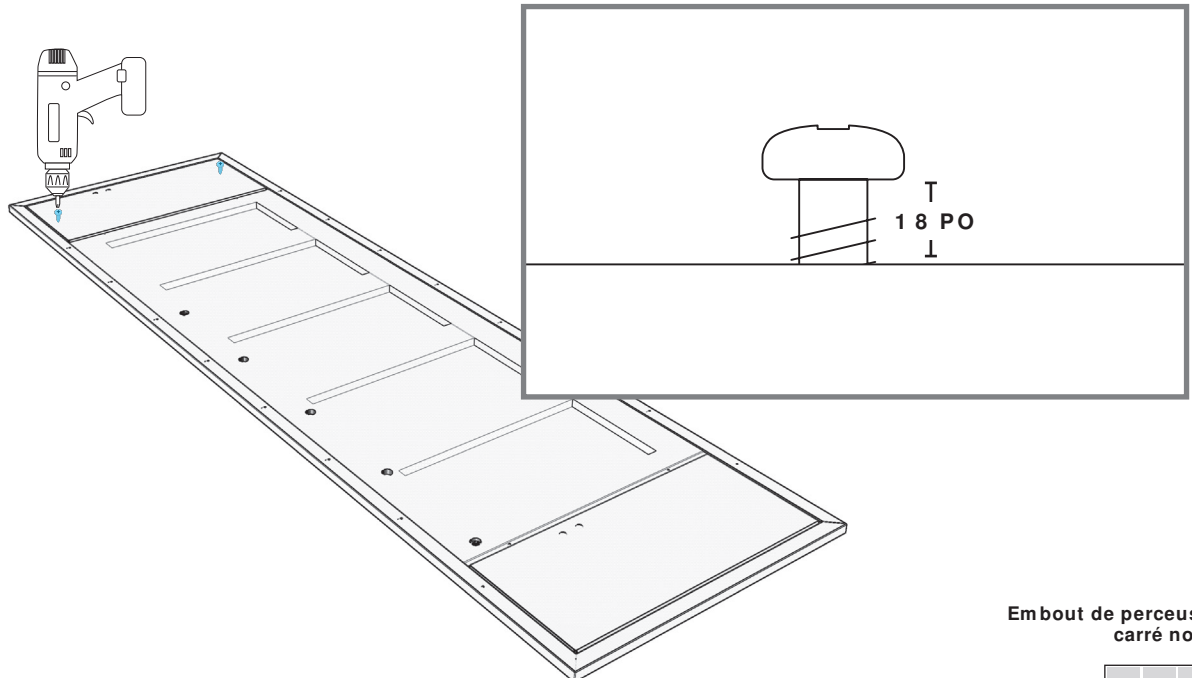

Embout de perceuse
carré no 2



15

SUSPENSION ET ALIGNEMENT DU

PANNEAU

15.1

POUR CHAQUE APPAREIL : PLACER LES ATTACHES DANS LES FENTES DU HAUT DES GARNITURES
D'AJUSTEMENT DE PORTE.

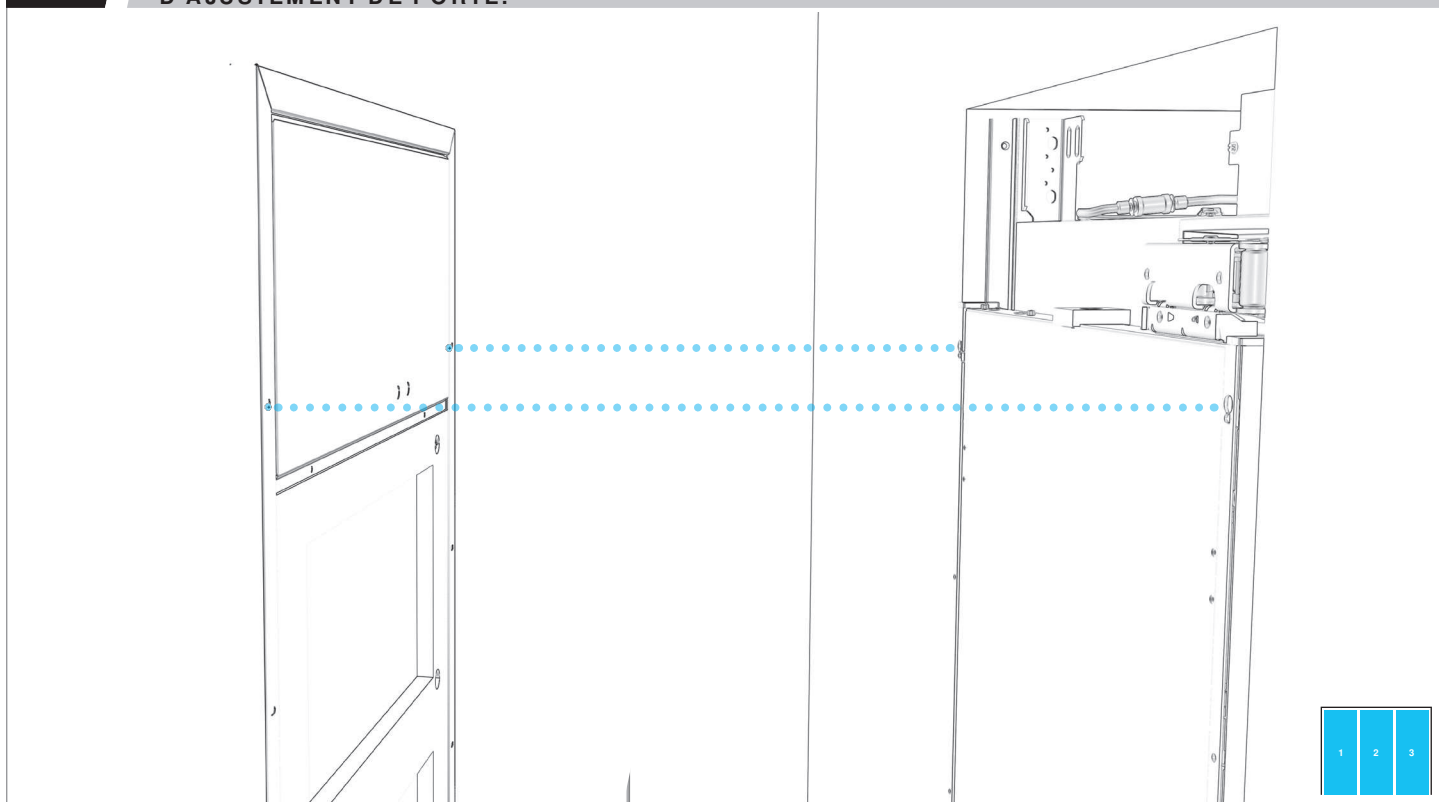

15.2

POUR CHAQUE APPAREIL : AJUSTER MANUELLEMENT LA POSITION DU PANNEAU DE PORTE.

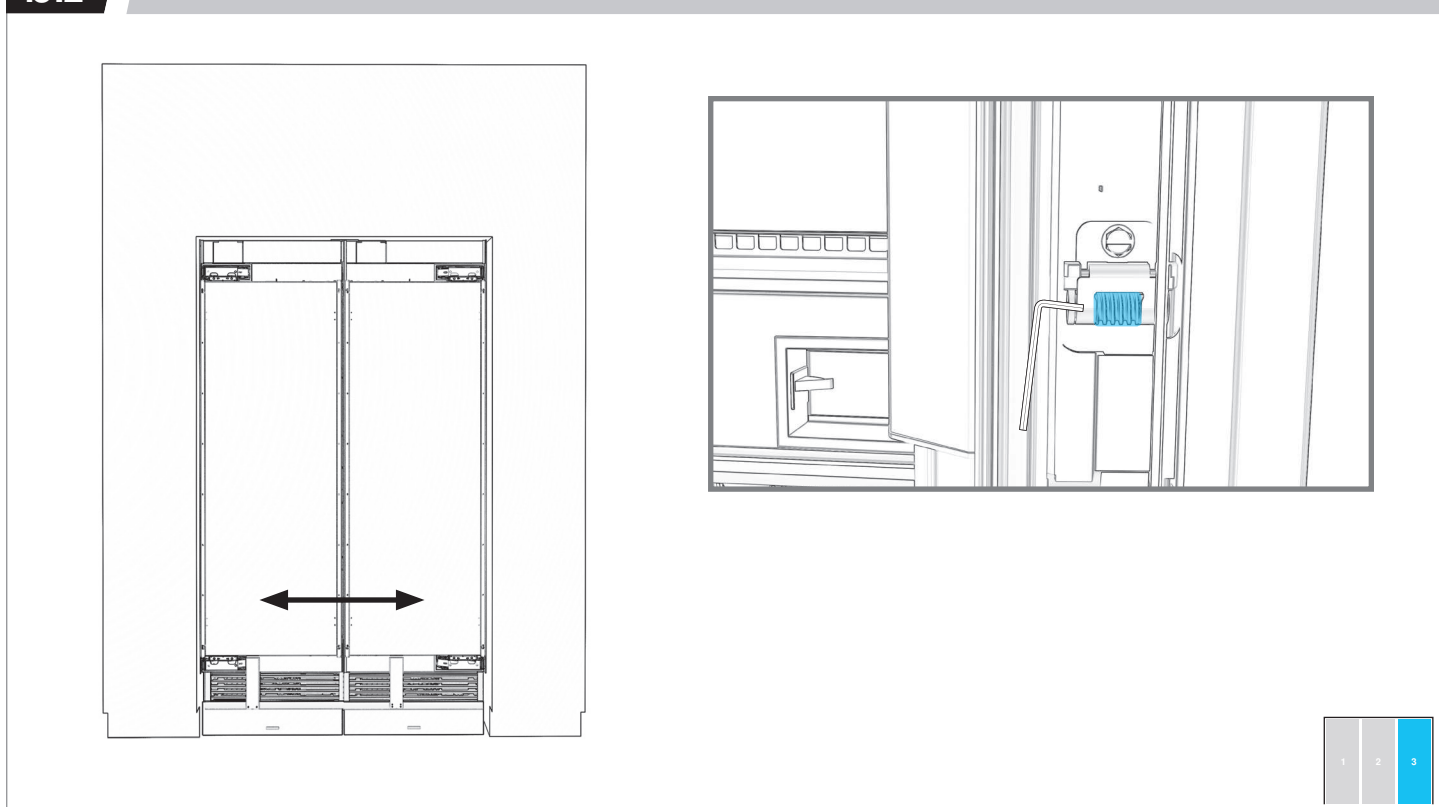

15.3

POUR CHAQUE APPAREIL : SERRER LES DEUX ATTACHES SUPÉRIEURES.

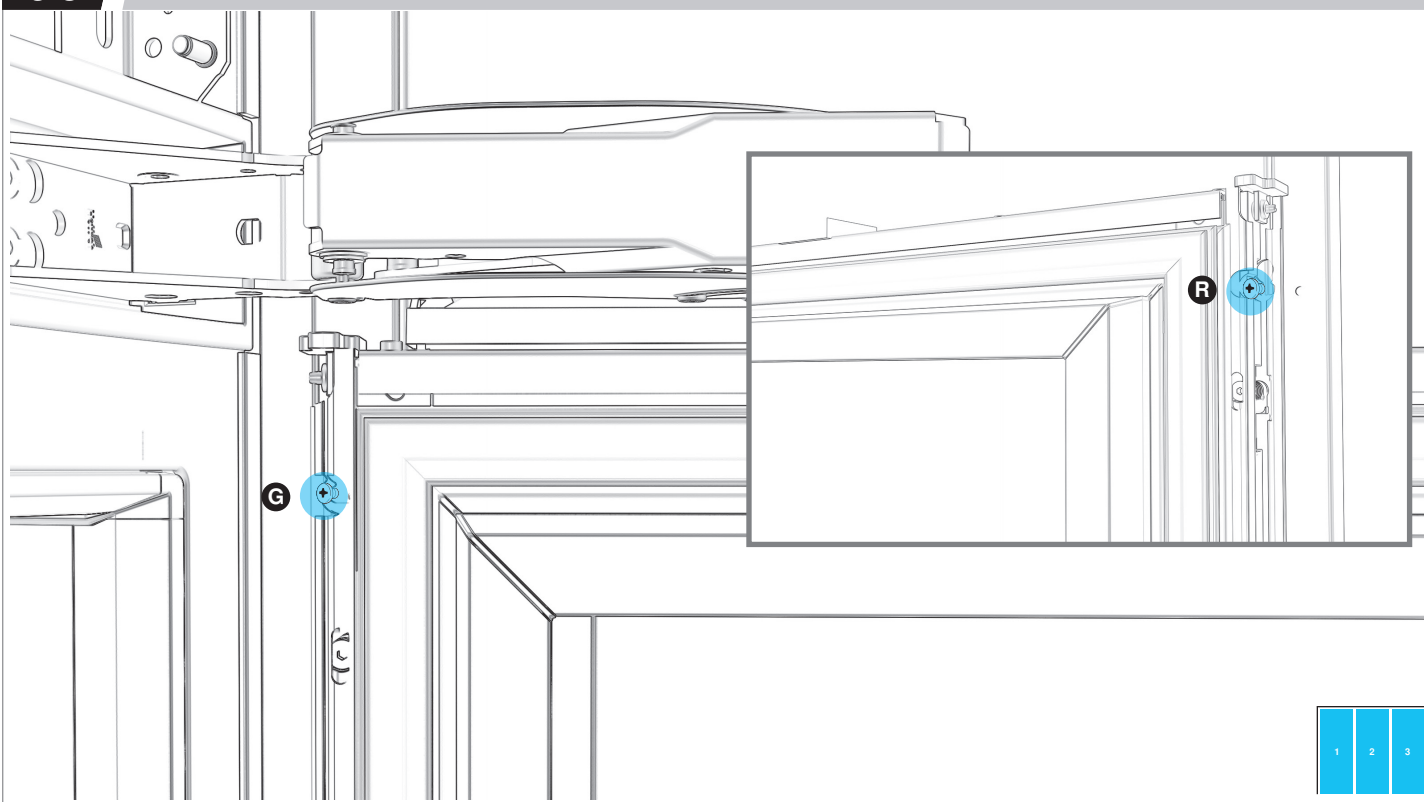

15.4

POUR CHAQUE APPAREIL : PLACER SANS SERRER DEUX ATTACHES DU BAS.

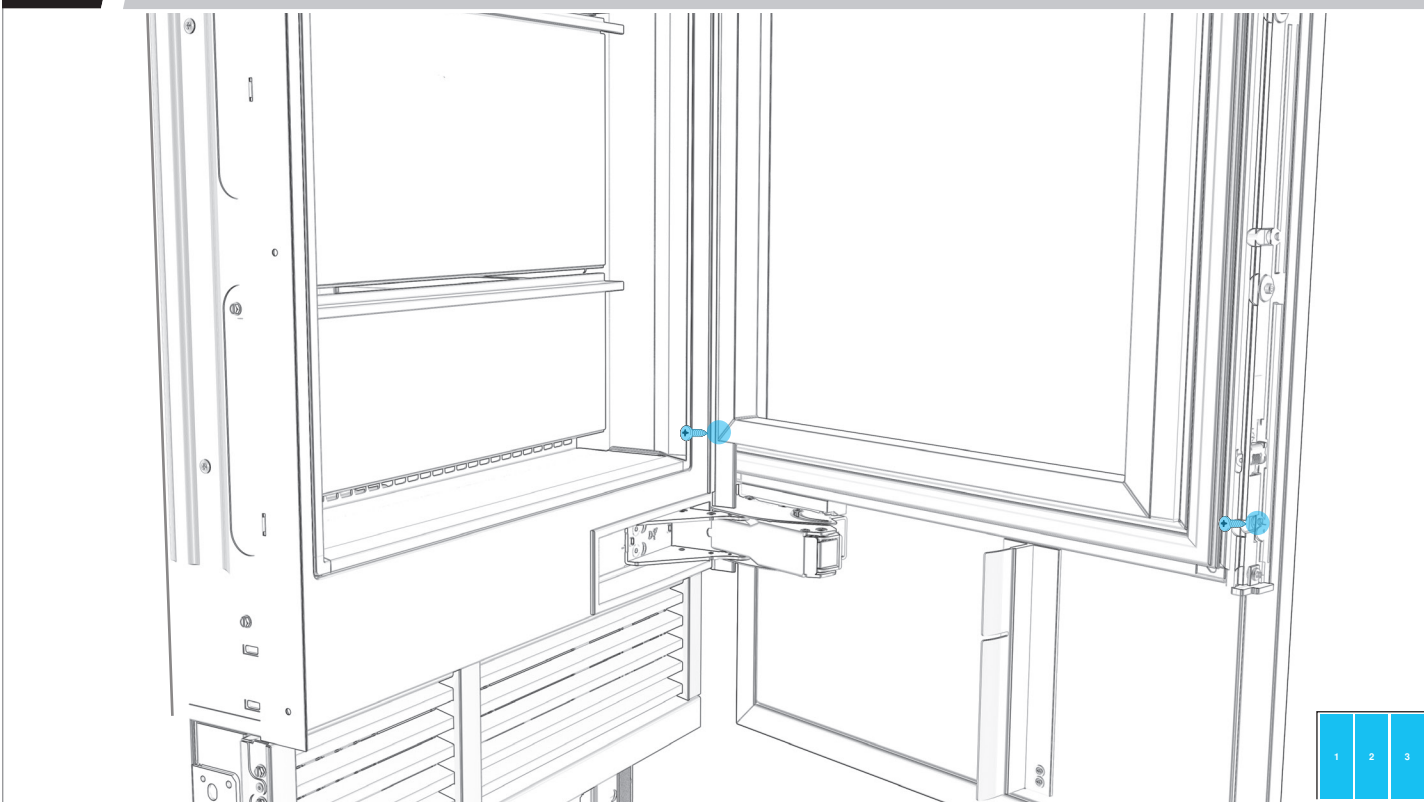

15.5

POUR CHAQUE APPAREIL : DESSERRER SIX VIS D'AJUSTEMENT PAR CÔTÉ.

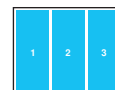
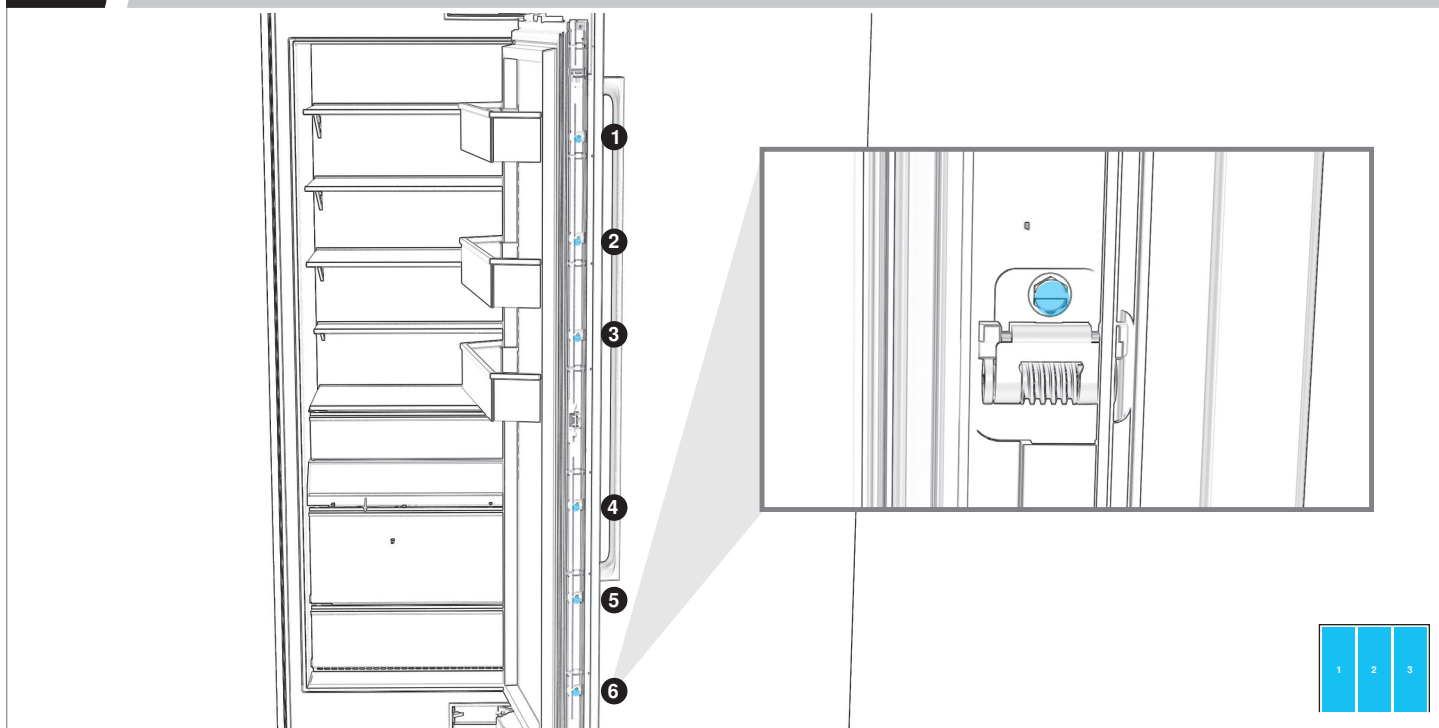

UTILISER UN ADAPTATEUR À ANGLE DROIT POUR PLUS DE FACILITÉ.

15.6

POUR CHAQUE APPAREIL : AJUSTER LA HAUTEUR DU PANNEAU DE PORTE.

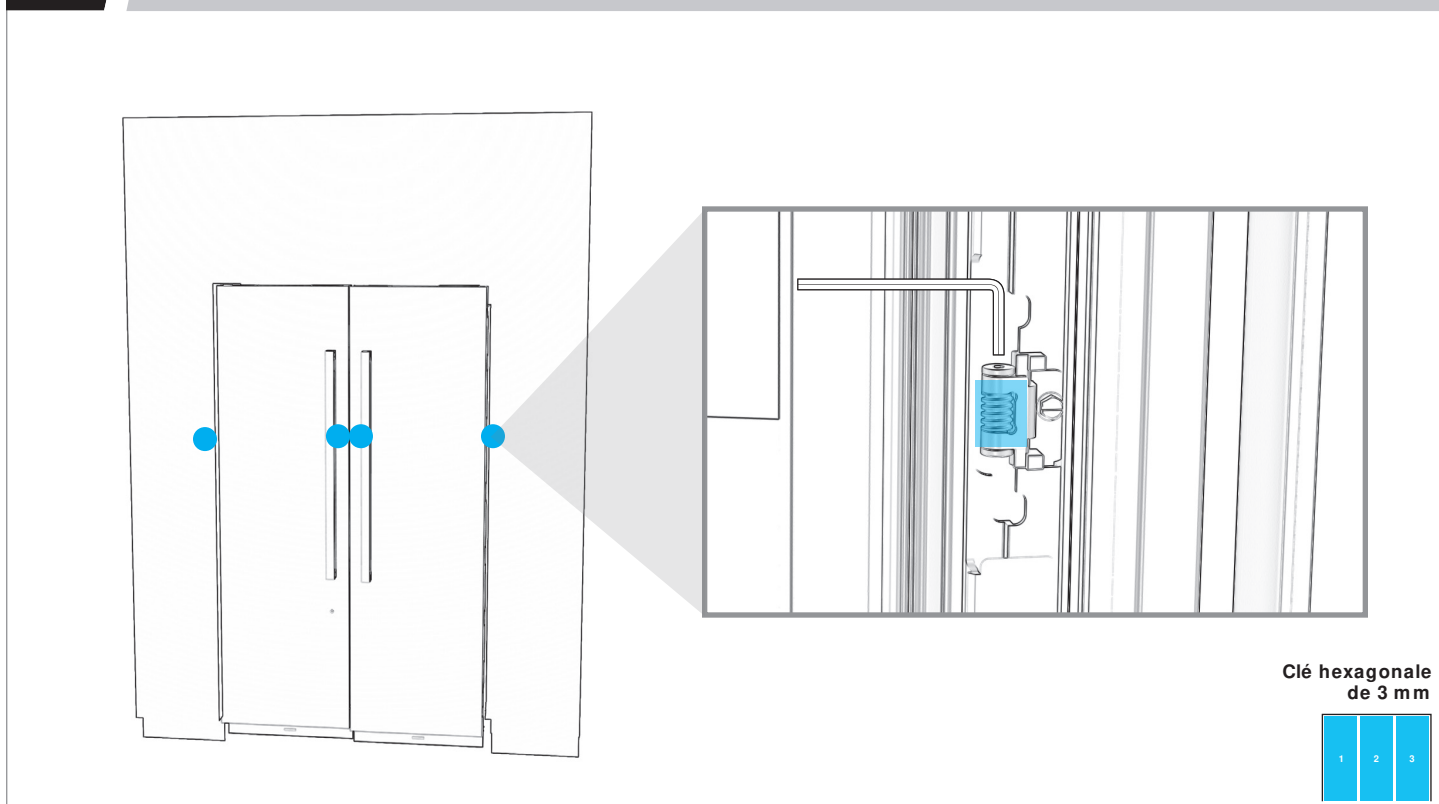
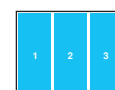
Clé hexagonale
de 3 mm

15.7

POUR CHAQUE APPAREIL : AJUSTER LA PROFONDEUR DE PORTE.

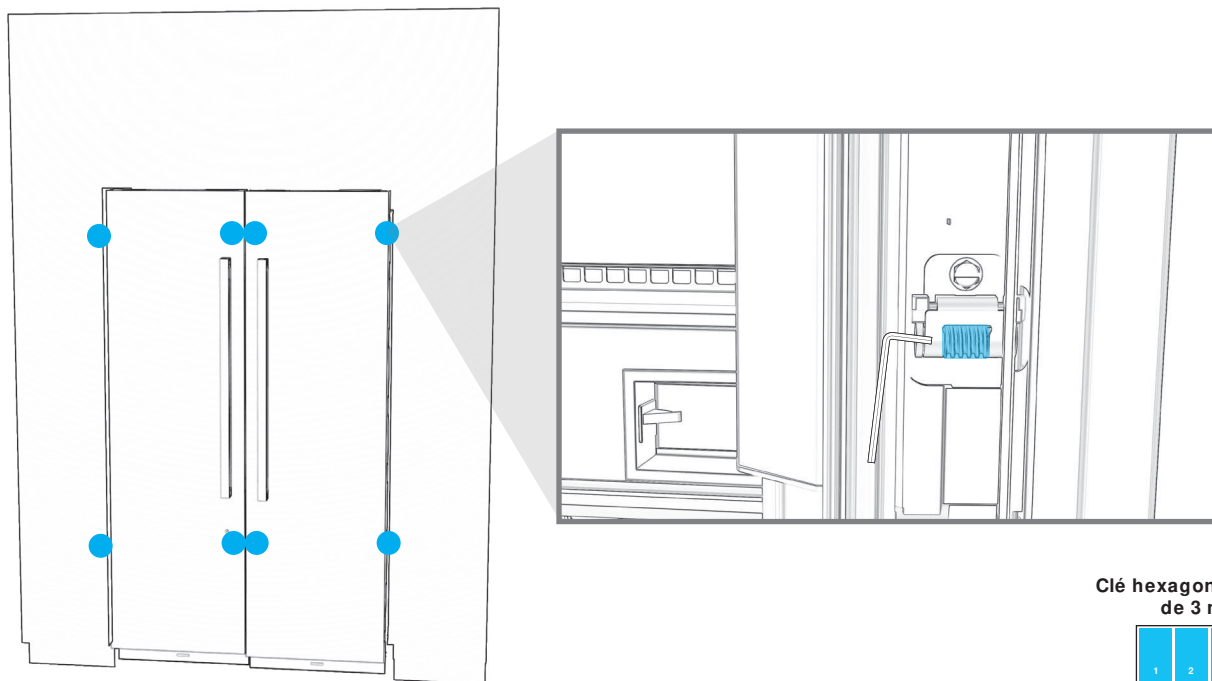

Clé hexagonale
de 3 mm

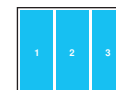

15.8

POUR CHAQUE APPAREIL : VÉRIFIER QUE LES PANNEAUX DE PORTE SONT ALIGNÉS ENTRE EUX ET AVEC LE MEUBLE.

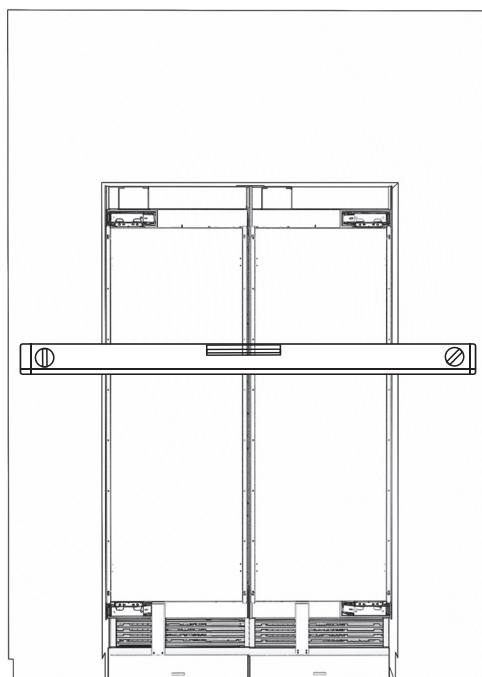

15

SUSPENSION ET ALIGNEMENT DU PANNEAU

15.9

POUR CHAQUE APPAREIL : PLACER ET SERRER LES 16 ATTACHES.

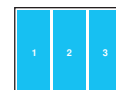
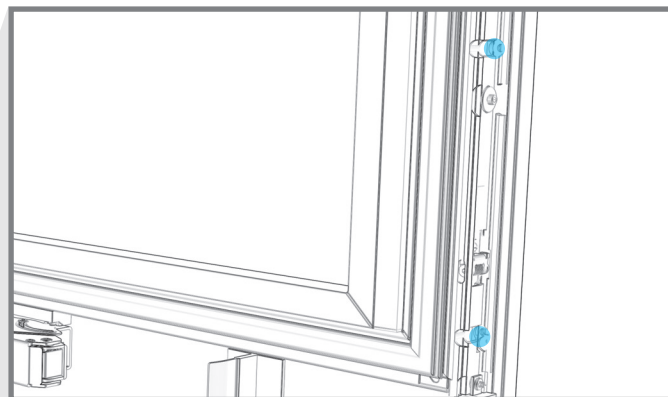
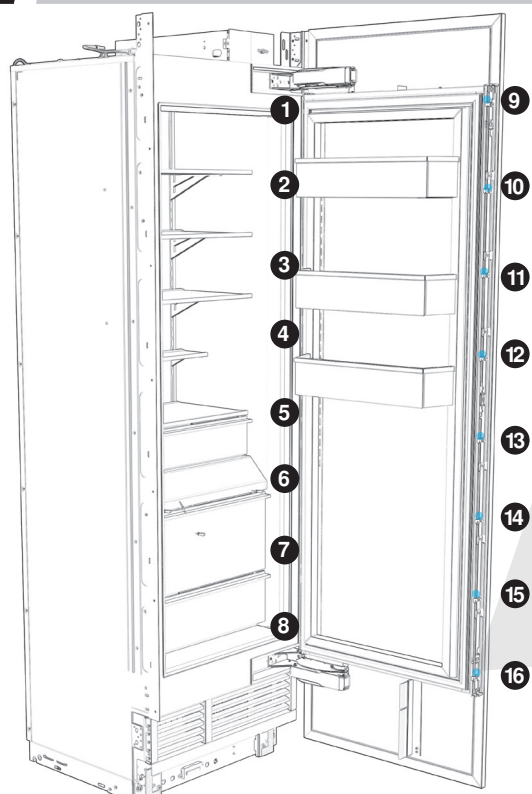

15.10

POUR CHAQUE APPAREIL : SERRER LE PANNEAU DE PORTE.

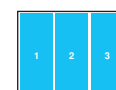
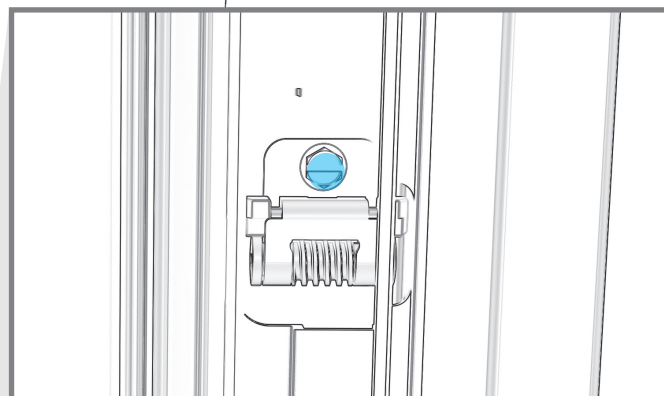
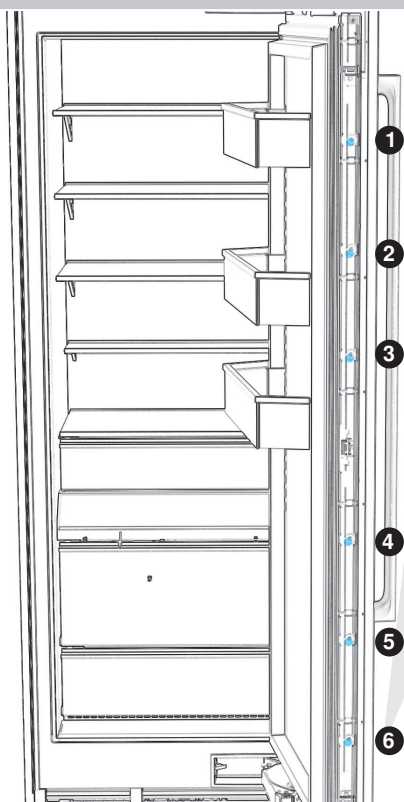

15.11

POUR CHAQUE APPAREIL : RÉINSTALLER LES GARNITURES DE BRIDE.

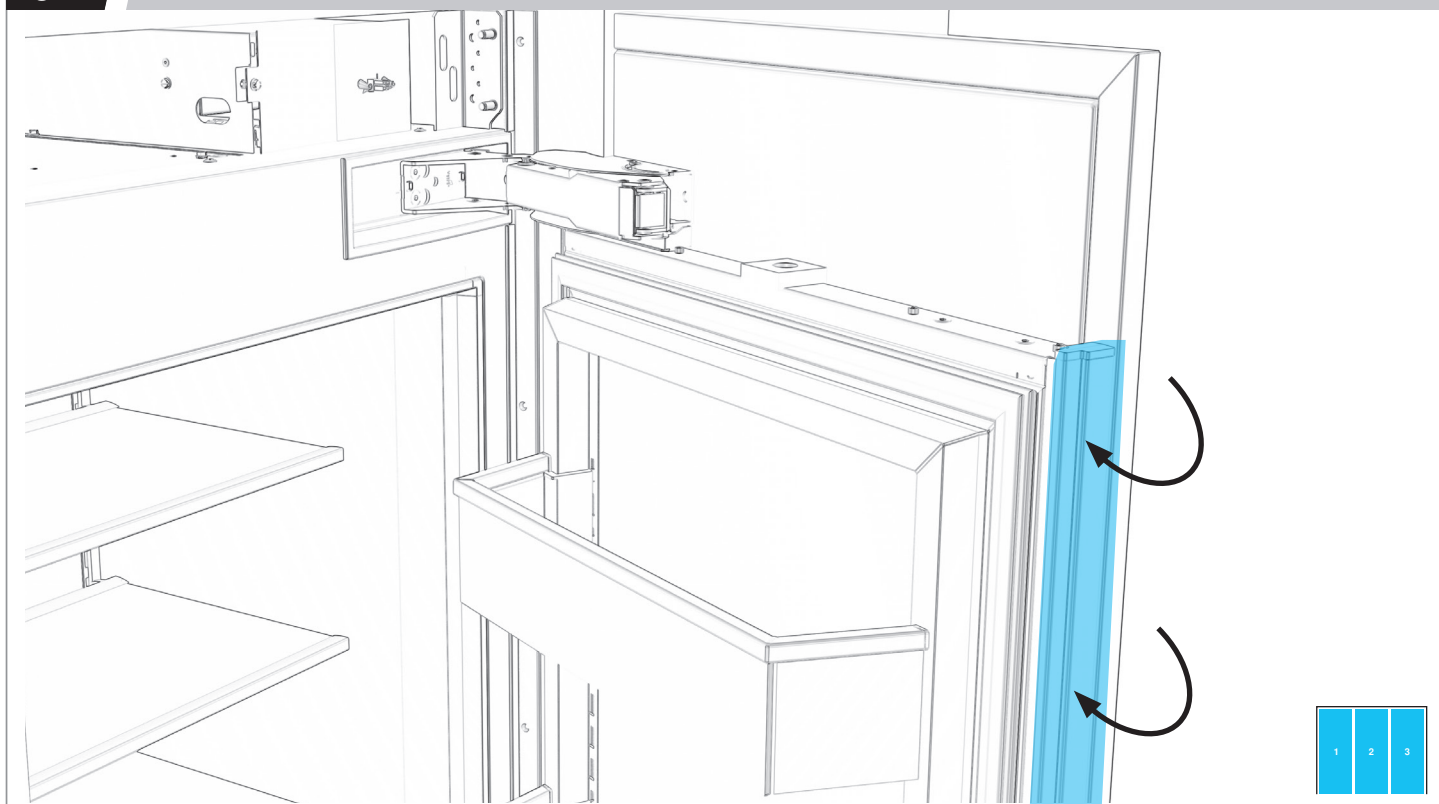

TERMINER

L'INSTALLATION

16.1

POUR CHAQUE APPAREIL : SERRER LES VIS POUR BIEN FIXER LES GARNITURES DE CÔTÉ DE CHAQUE CÔTÉ.

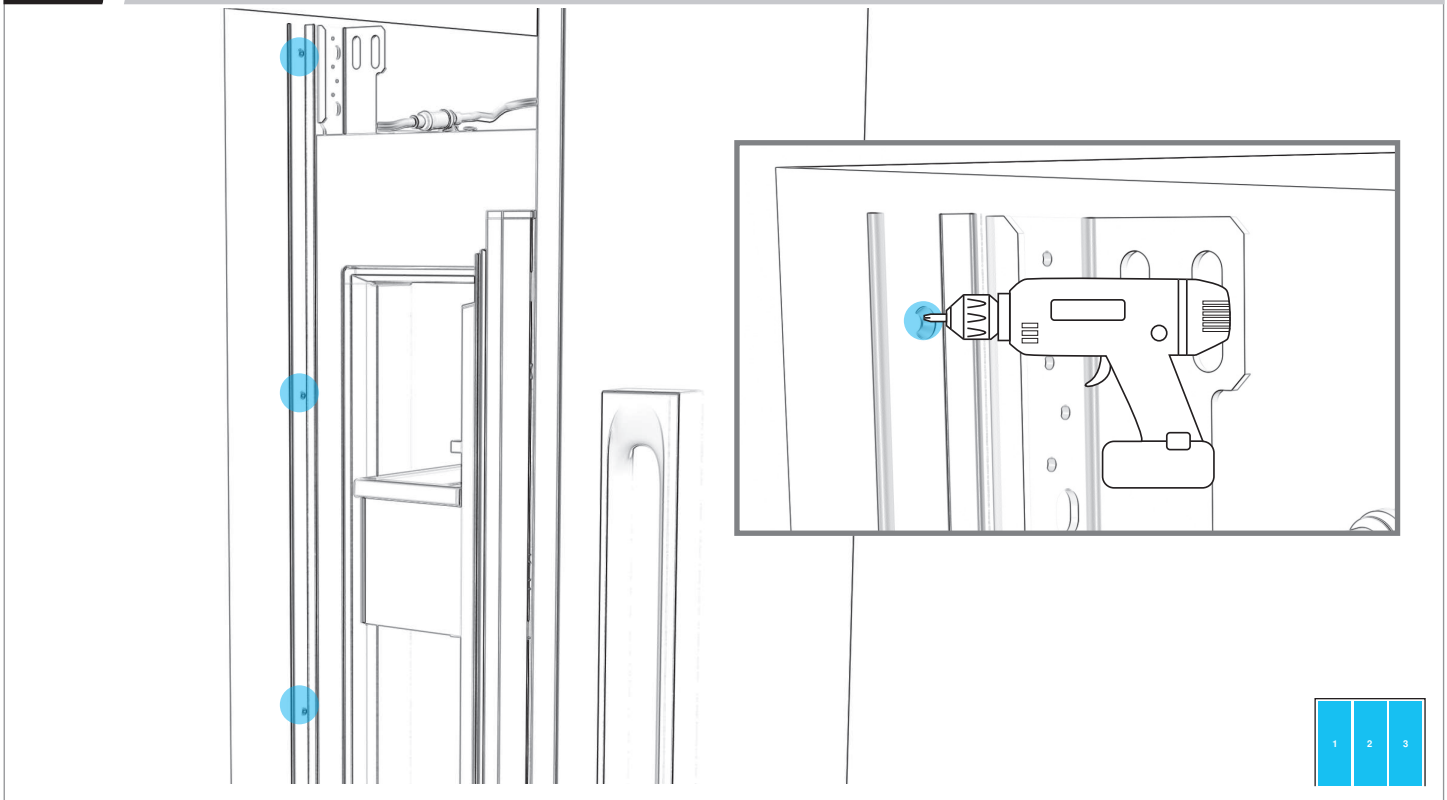

16.2

POUR CHAQUE APPAREIL : FIXER LES SÉPARATEURS D'AIR AUX PANNEAUX DE PORTE.

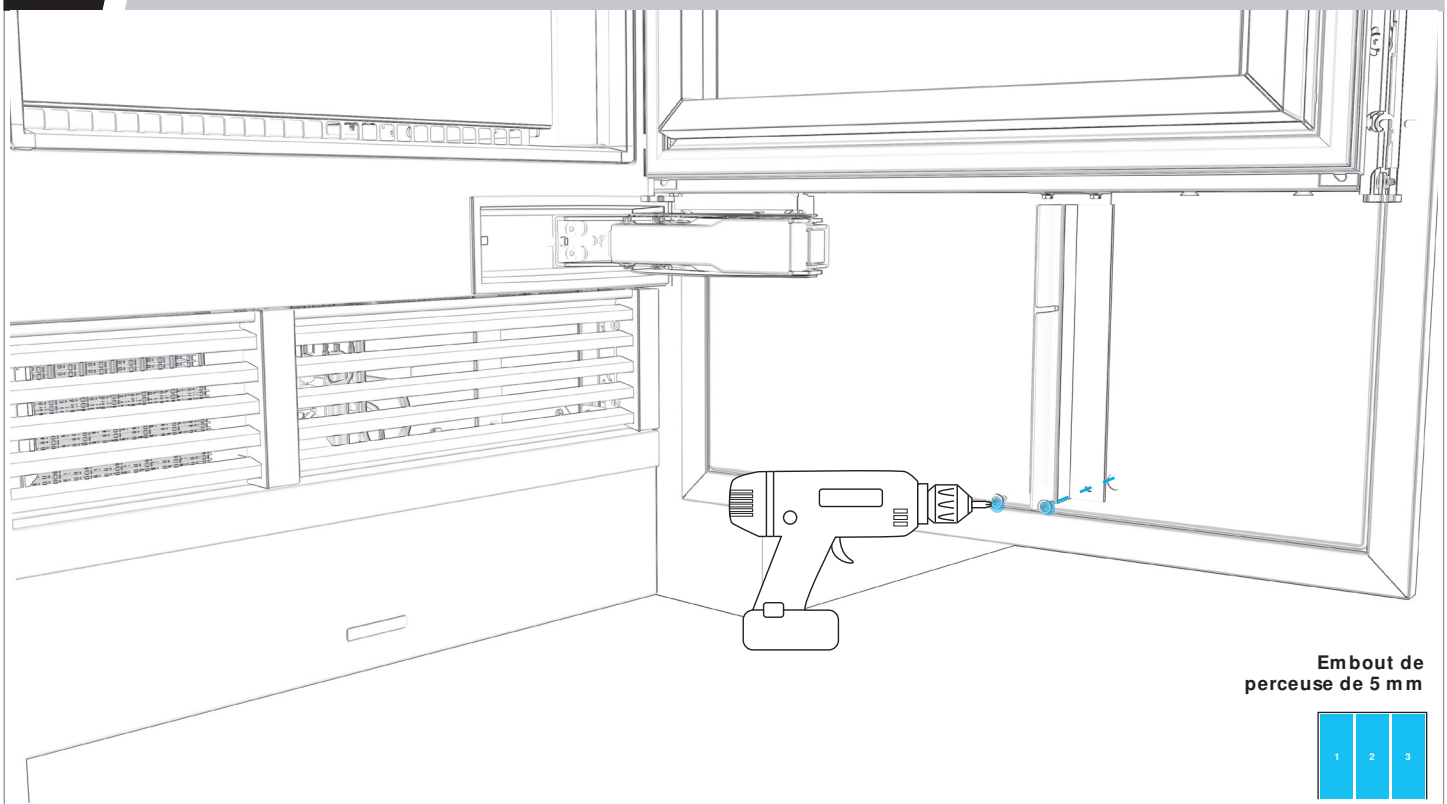

16.3

POUR CHAQUE APPAREIL : RETIRER LA PELLICULE.

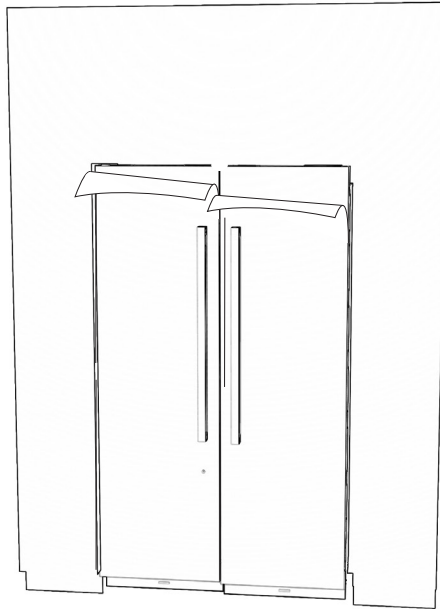

LIRE LES AVERTISSEMENTS AVANT LES DERNIÈRES VÉRIFICATIONS.

⚠ AVERTISSEMENT**Risque de choc électrique****Brancher sur une prise à 3 alvéoles reliée à la terre.****Ne pas enlever la broche de liaison à la terre.****Ne pas utiliser un adaptateur.****Ne pas utiliser un câble de rallonge.****Le non-respect de ces instructions peut causer un décès, un incendie ou un choc électrique.**

DERNIÈRES VÉRIFICATIONS

- Il ne reste aucun emballage chez le client
- Les appareils sont branchés, alimentés et fonctionnent bien
- Les appareils sont de niveau
- Les panneaux sont alignés et ont été vérifiés après 20 minutes de fonctionnement
- L'alimentation en eau est bien raccordée, il n'y a pas de fuite
- Les filtres à eau sont installés (ne s'applique pas s'il y a un système d'osmose inverse)
- Les distributeurs d'eau et machines à glaçons fonctionnent bien
- Tous les problèmes en lien avec l'installation ou les pièces ont été mentionnés à JennAir Epicenter

PRÉSENTATION AU CLIENT

Fournir le guide d'utilisation au client s'il est présent.
Indiquer au client comment :

- Fonctionner le panneau de commande
- Configurer l'application et la connexion Wi-Fi
- Jeter les premières quantités de glaçons produites
- Remplacer les filtres à eau
- Enregistrer ses appareils
- Comment communiquer avec JennAir Epicenter à partir de jennair.com ou en composant le 1800 JENNAIR (536-6247)

NOTES

NOTES

NOTES

NOTES

