



**VG295250CA**  
**Gas cooktop 200 series**  
**Width 90 cm**  
**Natural gas 15 mbar**  
**Wok burner with 5.5 KW**

Control panel for comfortable and secure operation  
Mechanical power level regulation for 9 power levels, with exact setting and reproduction of flame size  
Multi-ring burner of solid, heat-resistant brass as used in professional kitchen  
Solid smooth-surface cast iron pan supports  
Top appliance in the market, 17.5 kW on 5 burners

#### Cooking zones

1 multi-ring wok burner (300 W – 5500 W), suitable for pots up to max. ø 32 cm.  
2 two-ring high output burners (170 W – 4000 W), suitable for pots up to max. ø 28 cm.  
2 two-ring standard burners (170 W – 2000 W), suitable for pots up to max. ø 28 cm.

#### Handling

Control knobs with illuminated ring.  
Integrated control panel.  
One-handed operation.  
Electric ignition.

#### Features

Three-part cast iron pan support with flat, continuous pot surface.  
Brass burner rings.

#### Safety

Thermoelectric safety pilot.  
Residual heat indication.  
Operation indicator.

#### Planning notes

No intermediate shelf required.  
Appliance can be snapped into the worktop from above.  
Rear panel and wall trims must be heat-resistant and consist of a non-flammable material.  
Installation in a 90 cm wide lower cabinet is required.  
A minimum lateral clearance of at least 11 13/16" from adjacent heat-sensitive furniture or contact surfaces must be observed or thermal insulation fitted.  
With a total connected load of more than 11 kW local regulations concerning room ventilation, room size and combination of extraction or recirculation hoods must be observed.  
Minimum clearance between gas cooktop(s) with more than 11 kW and ventilation hood 70 cm.  
Appliance weight: approx. 29.

#### Connection

Total connected load gas 17.5 KW.  
Total connected load electric 10.0 W.  
Connecting cable 1.5 m with plug.

#### Product Features

**Product name / series name**  
gas hob w integrated controls

**Construction type**  
Built-in

**Energy source**  
Gas

**Total number of cooktop burners**  
5

**Required cutout size (HxWxD)**  
106 x 885 x 492

**Width of the appliance**  
914

**Dimensions**  
106 x 914 x 510

**Product packaging dimensions (HxWxD)**  
290 x 700 x 1010

**Net weight**  
28.9

**Gross weight**  
31.2

**Residual heat indicator**  
Separate

**Location of control panel**  
Hob front

**Basic surface material**  
brushed stainless steel

**Color of surface**  
Stainless steel

**Color of frame**  
Stainless steel

**Approval certificates**  
CSA, CSA, CSA

**Power cord length**  
150

**Watts**  
10

**Gas connection rating**  
17500

**Fuse protection**  
15

**Volts**  
110-120

**Frequency**  
60

#### Consumption and connection features

2022-04-05  
Page 1

#### Color Variants

**VG295250CA**  
**Width 90 cm**  
**Natural gas 15 mbar**

#### Included accessories

1 x WOK attachment ring.

#### Optional accessories

**WP400001**  
**Wok pan made of multiple-layer material**

VG295250CA

Gas cooktop 200 series

Width 90 cm

Natural gas 15 mbar

Wok burner with 5.5 KW

2022-04-05

Page 2

Gas connection

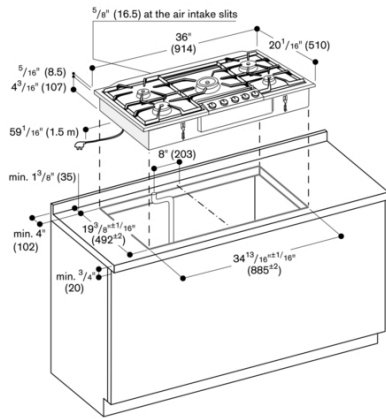
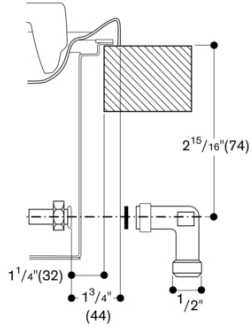

Minimum distance from the appliance cut-out to the side wall 11 (300 mm).