

FULGOR MILANO

30"-36" Full Gas Ranges 600 SERIES

Weight & Dimensions

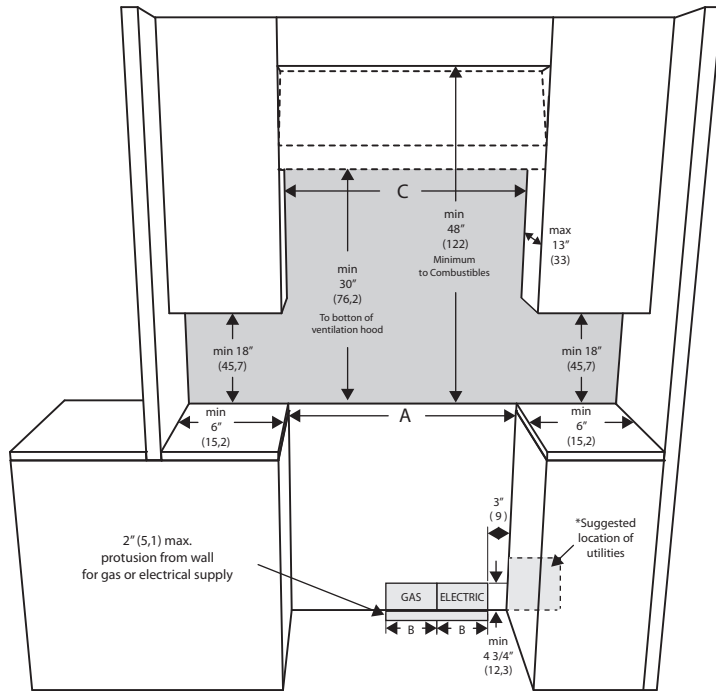

| OPENING WIDTH | A & C | B |
|---------------|------------|-----------|
| Range 30" | 30" (76,2) | 6" (15,2) |
| Range 36" | 36" (91,4) | 7" (17,8) |

SHADED AREA:

The surface of the entire back wall above the range and below the hood must be covered with a noncombustible material.

*Consult local code for exact location requirements.

Note: Clearances from non-combustible materials are not part of the ANSI Z21.1 scope and not certified. Clearances to non-combustible materials must conform with local codes or, in the absence of local codes, with the National Fuel Gas Code, ANSI Z223.1/NFPA 54.

Minimum clearances:

Above cooking surface (above 36" [91.4 cm])

- Sides - 6" (15.2 cm)
- Within 6" (15.2 cm) side clearance, wall cabinets no deeper than 13" (33.0 cm) must be minimum 18" (45.7 cm) above cooking surface
- Wall cabinets directly above product must be a minimum of 48" (122 cm) above cooking surface.
- Rear - 0" with 9" backguard; 0" with non-combustible rear wall.

Below cooking surface (36" [91.4 cm] and below)

- Install with zero clearance between adjacent combustible construction below the cooking surface and the back and sides of the appliance

ADDITIONAL CLEARANCES:

For island installation, maintain 2-1/2 in. minimum from cutout to back edge of countertop and 3 in. minimum from cutout to side edges of countertop (see top view). For island installation, 12" (305) minimum clearance back of range to combustible rear wall above countertop. The island installation is not part of the ANSI Z21.1 scope and not certified.

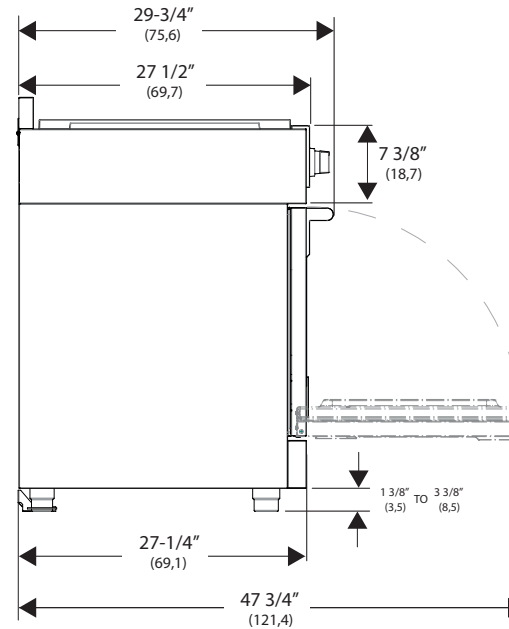
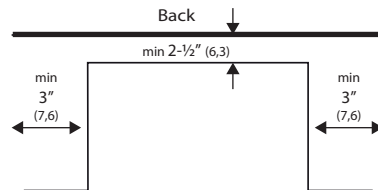

| PACKAGING 30" | | lb / inch | Kg / mm |
|---------------|---|-----------|---------|
| GROSS WEIGHT | | 322 lb | 146 Kg |
| DIMENSION | W | 33" | 840 |
| | D | 45"3/4 | 1162 |
| | H | 32"1/4 | 820 |

| PACKAGING 36" | | lb / inch | Kg / mm |
|---------------|---|-----------|---------|
| GROSS WEIGHT | | 377 lb | 171 Kg |
| DIMENSION | W | 39" | 990 |
| | D | 45"3/4 | 1162 |
| | H | 32"1/4 | 820 |

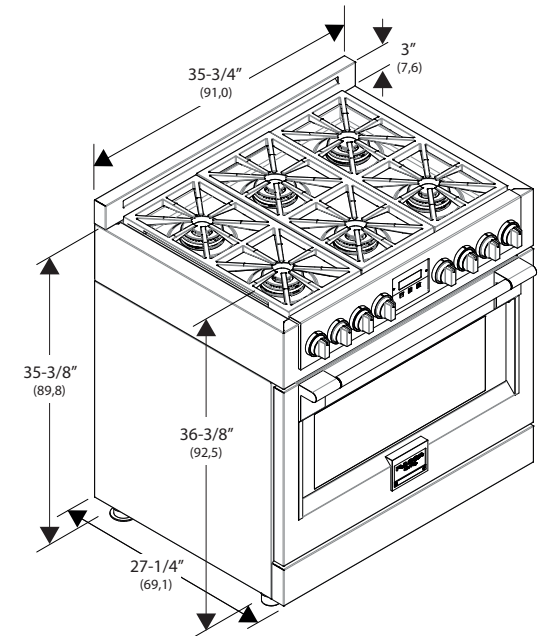
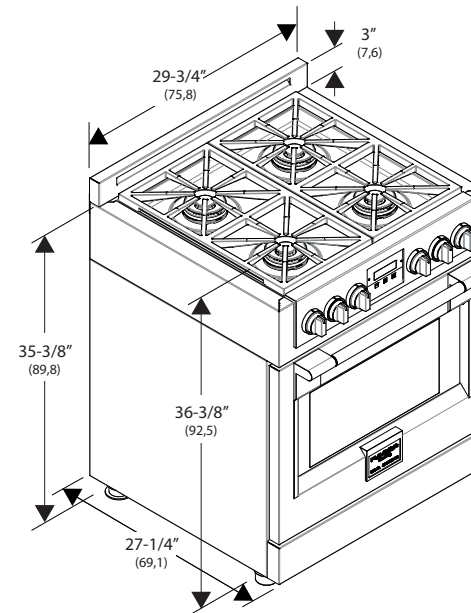

FULGOR

MILANO

600 Series 36" Gas Range

F6PGR366S1

BAR CODE (EAN 13)

801980101610 5

Series

| | |
|----------------------------|-----------------|
| | 600 |
| | FULL GAS |
| Size | 36" |
| Main Colour | SS |
| Logo | • |
| Stainless Steel Aesthetics | Professional |

Cooktop

Type

| | |
|-----------------|----------------|
| | GAS |
| Cooking Surface | Black Enameled |
| Gas Type | NG or LP |
| Knobs | • |

Gas Cooktop Features

| | |
|---|---|
| Electric Flame Ignition and Re-ignition | • |
| Flame out sensing | • |
| Top Mount Injectors | • |
| L.P. Conversion Kit | • |
| Dual Flame Brass Burner | • |
| Heavy Duty Cast Iron Grates | 3 |
| Pressure Regulator | • |

Cooking Zones

Front Left **Dual Flame Burner**

| | |
|----------------------------|--|
| Power (Max/ Min) G20 - 5" | 18000 (BTU/h) - 5300W / 950 (BTU/h) - 275W |
| Power (Max/ Min) G31 - 10" | 15000 (BTU/h) - 4400W / 950 (BTU/h) - 275W |

Rear Left **Dual Flame Burner**

| | |
|----------------------------|--|
| Power (Max/ Min) G20 - 5" | 18000 (BTU/h) - 5300W / 950 (BTU/h) - 275W |
| Power (Max/ Min) G31 - 10" | 15000 (BTU/h) - 4400W / 950 (BTU/h) - 275W |

Front Middle **Dual Flame Burner**

| | |
|----------------------------|--|
| Power (Max/ Min) G20 - 5" | 18000 (BTU/h) - 5300W / 950 (BTU/h) - 275W |
| Power (Max/ Min) G31 - 10" | 15000 (BTU/h) - 4400W / 950 (BTU/h) - 275W |

Rear Middle **Dual Flame Burner**

| | |
|----------------------------|--|
| Power (Max/ Min) G20 - 5" | 18000 (BTU/h) - 5300W / 950 (BTU/h) - 275W |
| Power (Max/ Min) G31 - 10" | 15000 (BTU/h) - 4400W / 950 (BTU/h) - 275W |

Front Right **Dual Flame Burner**

| | |
|----------------------------|--|
| Power (Max/ Min) G20 - 5" | 18000 (BTU/h) - 5300W / 950 (BTU/h) - 275W |
| Power (Max/ Min) G31 - 10" | 15000 (BTU/h) - 4400W / 950 (BTU/h) - 275W |

Rear Right **Dual Flame Burner**

| | |
|----------------------------|--|
| Power (Max/ Min) G20 - 5" | 18000 (BTU/h) - 5300W / 950 (BTU/h) - 275W |
| Power (Max/ Min) G31 - 10" | 15000 (BTU/h) - 4400W / 950 (BTU/h) - 275W |



Oven

Type

| | |
|-----------|----------------------|
| | GAS |
| Oven Type | Multifunction 2 Fans |

FULGOR

MILANO

| Temperature Regulation | | Thermostat |
|--|--|---------------------------------------|
| Functions | | |
| Pizza (Lower Convection) |  | • |
| Down Bake |  | • |
| Broil |  | • |
| Control Panel | | |
| Control type | | Valve |
| Clock Display | | YES |
| Commands | | 8 Heavy Duty Knobs |
| Gas Oven Features | | |
| Electric Flame Ignition | | • |
| Flame out sensing | | • |
| Gas safety devices | | • |
| L.P. Conversion Kit | | • |
| Oven Door(s) | | |
| Oven Glass Window | | Deep Embossed Window |
| Door Cooling System | | 4 Pane Heat Resistant Glass |
| Door Hinges | | Heavy Duty Steady Tilt |
| Soft Closing System | | • |
| Handle Style | | Stainless Steel Tube d30mm, Pro style |
| Oven Cavity | | |
| Net Capacity (cuft) | | 4.9 |
| Cavity Enamel Colour | | Black |
| Rack Positions | | 6 |
| Oven Lights | | 3x20W Halogen |
| Broil Burner | | |
| Power (Max) G20 - 5" | | 18000 (BTU/h) - 5300W |
| Power (Max) G31 - 10" | | 17000 (BTU/h) - 5000W |
| Bake Burner | | |
| Power (Max/ Min) G20 - 5" | | 21500 (BTU/h) - 6300W |
| Power (Max/ Min) G31 - 10" | | 21500 (BTU/h) - 6300W |
| Oven Accessories | | |
| Chromed racks | | 2 |
| Enameled Grill set (basin + anti splash) | | 1 |
| Telescopic chromed rack | | 1 |
| Meat probe | | |
| Dimensions | | |
| Overall dim - width | | 35 3/4" (910mm) |
| Overall dim - height | | 38 3/8" (974mm) |
| Overall dim - depth | | 29 3/4" (756mm) |
| Power / Ratings (120V, 60 Hz) | | |
| KW/Amps rating at 120V, 60Hz | | 200W - 1.7A |
| Cable + Plug | | Nema 5-15P |
| INSTRUCTIONS FOR USE | | |
| Use & Care Manual | | EN, SP, FR |
| Installation Manual | | EN, SP, FR |