

# Integrated Double DishDrawer™ Dishwasher, Sanitize

Series 9 | Integrated

Panel Ready



Customize with your cabinetry for a seamless look. Each drawer washes independently so you can run one while you load the other.

- Knock to pause function is perfect if you miss a dish
- Six wash programs, as well as additional Quick wash, Sanitize and Extra Dry options
- Customize with your own kitchen cabinetry or purchase our stainless steel door panel accessory

- American Disabilities Act (ADA) compliant, this Double DishDrawer™ sits at an accessible height

## DIMENSIONS

<b>Height</b>	<b>32 5/16 - 34 5/8"</b>
<b>Width</b>	<b>23 9/16"</b>
<b>Depth</b>	<b>21 3/4"</b>

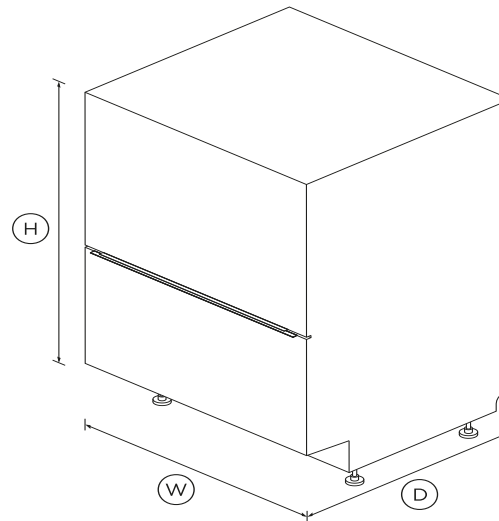

## FEATURES & BENEFITS

### SEAMLESS INTEGRATION

Slide your DishDrawer™ Dishwasher into an existing kitchen space or integrate into kitchen cabinetry, for a seamless look whilst delivering superior dish care.

### EASE OF USE

DishDrawer™ Dishwashers are as easy to open and close as

kitchen drawers and can be conveniently positioned at bench height for ease of loading and minimal bending. Flexible racking allows you to make adjustments to fit in a variety of dishes.

### INDEPENDENT WASH

With the ability to use both drawers independently and select different wash programs the DishDrawer™ Dishwasher can wash everything from fine glass and crystal to heavily soiled pots and pans.

### TRUE HALF LOAD

Each drawer holds a true half load for guilt-free small washes and fast turnaround of your dishes. Both drawers operate independently so different wash cycles can run simultaneously to accommodate a variety of loads.

### QUICK, SANITIZE AND EXTRA DRY OPTIONS

The Quick wash modifier delivers a faster wash while maintaining performance. The Sanitize option provides extra protection killing 99.9% of bacteria in the final rinse. The Extra Dry setting is perfect for plastic dishes.

### KNOCK TO PAUSE

Instead of needing a remote control, these DishDrawer™ Dishwashers have a knock to pause function. A knock on the front panel will pause the dishwasher which can be re-started again by using the start/play button.

### QUIET PERFORMER

Running at a very low decibel rating, these DishDrawer™ dishwashers do their job without making a fuss. The combination of intelligent technology and simple mechanics means greater reliability and excellent wash performance.

## SPECIFICATIONS

### Accessories

- Cutlery basket
- Kickstrip
- Knife clip and multipurpose

**Accessories (sold separately)**

Door panel stainless steel	<b>ADDD24DPX</b>
Handle kit Contemporary	<b>AHS-OBDD-60S</b>
Handle kit Contemporary	<b>AHD5-OBDD-60SX</b>
Handle kit Contemporary	<b>AHD5-OBDD-60SB</b>
Handle kit Contemporary	<b>AHD3-OBDD-60S</b>
Handle kit Professional round	<b>AHP3-DWDD-SX</b>

**Capacity and loading**

Accommodates round plates	<b>11" (top drawer) 11" (bottom)</b>
Adjustable height, foldable	•
Fold down tines	•
Pitch adjustable tines	•
Place settings	<b>14</b>

**Consumption**

Energy usage	<b>263kWh/year</b>
Water usage (per wash cycle)	<b>3.28 gal running both tubs</b>

**Controls**

Child lock	•
Electronic fault/Diagnostic	•
End of cycle beeps	•
Energy saving delay start	•
Internal wash selector	•
Knock to pause	•
Rinse aid indicator light	•
Wi-Fi connectivity	•

**Features**

Fan assisted drying	•
Flood protection	•
Flow through detergent	•
Quiet operation	•
SmartDrive™ technology	•

**Performance**

Noise on standard cycle top	<b>43dBA</b>
-----------------------------	--------------

**Power requirements**

Amperage	<b>10A</b>
Electric circuit	<b>3 wire</b>
Rated current	<b>15A</b>
Supply frequency	<b>60Hz</b>
Supply voltage	<b>100 - 120V</b>

**Product dimensions**

Depth	<b>21 3/4"</b>
Height	<b>32 5/16 - 34 5/8"</b>
Width	<b>23 9/16"</b>

**Safety and compliance**

ADA compliant	•
---------------	---

**Warranty**

Parts and labor	<b>Limited 2 years</b>
-----------------	------------------------

**Wash Program Modifiers**

Extra Dry	•
-----------	---

Quick	•
Sanitize	•
Wash modifiers	<b>3</b>

**Wash Programs**

Delicate	•
Eco	•
Fast	•
Heavy	•
Medium	•
Rinse	•
Wash programs	<b>6</b>

**Water connection**

Inlet water temperature	<b>Max 140°F</b>
Supplied hose to suit 3/8"	•
Water pressure	<b>30kPa - 1000 kPa</b>
Water supply	<b>3/8" to suit Male Compression</b>

SKU	<b>82339</b>
-----	--------------

The product dimensions and specifications in this page apply to the specific product and model. Under our policy of continuous improvement, these dimensions and specifications may change at any time. You should therefore check with Fisher & Paykel's Customer Care Centre to ensure this page correctly describes the model currently available. ? Fisher & Paykel Appliances Ltd 2020

---

Other product downloads available at [fisherpaykel.com](https://fisherpaykel.com)



Quick Start Guide



Service & Warranty



Energy Label Double DishDrawer™ Dishwasher



User Guide DishDrawer™ Dishwasher



Energy Label Double DishDrawer™ Dishwasher



Installation Guide Double DishDrawer™ Dishwasher



Installation Guide Double DishDrawer™ Dishwasher



Specification Guide DoubleDishDrawer™ Dishwasher



Data Sheet Integrated Double DishDrawer™ Dishwasher



**A PEACE OF MIND SALE**

24 Hours 7 Days a Week Customer Support

T 1.888.936.7872 W [www.fisherpaykel.com](https://www.fisherpaykel.com)