

Dual Fuel Range, 48", 4 Burners, 4 Induction Zones, Self-cleaning

Series 9 | Professional

Stainless Steel | Natural gas



With both induction and gas cooktops and two convection ovens, you're ready to create a feast - guided by an intuitive touchscreen.

- Guided cooking using your touchscreen makes it simple to cook by food, function or recipe.
- Top burner heat of 23,500 BTU, for seriously fast boiling
- Four induction cooking zones, which can be paired to form two SmartZones

- 6.9 cu ft total oven capacity across two oven cavities

DIMENSIONS

Height	35 ³ / ₄ - 36 ³ / ₄ "
Width	47 ⁷ / ₈ "
Depth	29 ¹ / ₈ "

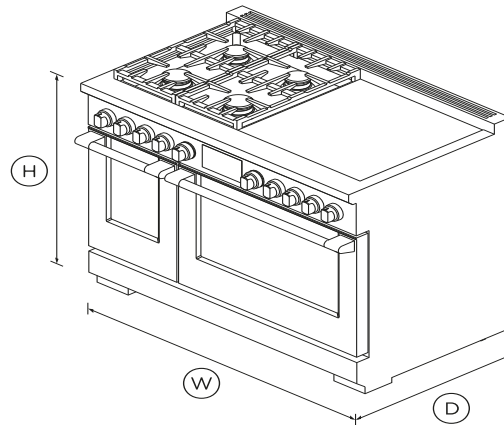

FEATURES & BENEFITS

Cook with confidence

Our touchscreen interface provides an intuitive guided cooking experience that helps deliver perfect results, whether you've been cooking all your life or just starting out. Cook with a favorite method, a hero ingredient, or a go-to cooking function or recipe. The screen tilts for improved ergonomics and optimal visibility while cooking.

Generous capacity

Two independently operating cavities provide a large total capacity of 4.8 cu. ft. in the main cavity and 2.1 cu. ft. in the secondary. That's enough room for a 32 lb turkey in one oven, and your sides in the other.

Cooking flexibility

No matter what you're cooking, you've got the right heat to get perfect results. Each of the 15 oven functions in the main cavity and 11 in the secondary have been extensively researched and carefully designed to cater to a broad range of dishes and cooking styles. The handy food probe helps you monitor your progress.

Cooktop power

On the gas side of the cooktop, Sealed dual flow burners deliver power up to 23,500 BTU, while the induction side delivers up to 3700W. This finely tuned cooktop provides instant and immediate control from the highest heat to the most gentle simmer.

Design quality

This range has craftsmanship in every detail, with real stainless steel, high-quality glass, and beautifully weighted, halo illuminated dials. Each cavity features incandescent lights and full extension telescopic racks. From the robust legs to the powerful cooktop, this Range is built to last.

Easy to clean

The oven features a self-cleaning function and self-clean proof side racks, which don't need to be removed when using this function. The induction zones only need a quick wipe after use to keep them clean.

SPECIFICATIONS

Accessories

Square handle option

AH-R48

Cleaning

- Pyrolytic self-clean •

Controls

- High resolution display •
- Metal illuminated dials •
- Sabbath mode •
- Wifi connectivity •

Gas requirements

- Fitting and pipe $\frac{1}{2}$ NPT, min. $\frac{5}{8}$ " Ø flex line
- Supply Pressure (natural gas) 6" to 9" W.C

Main oven features

- Capacity total (AHAM) 4.8cu ft
- Capacity usable (AHAM) 3.8cu ft
- Large broil pan •
- Self cleaning •
- Shelf positions 5
- True convection •

Main oven functions

- Bake 4600W
- Broil 4000W
- Clean •
- Convection broil •
- Number of main oven 15

Oven features

- Concealed element •

- Electronic oven control •
- Full extension telescopic 2
- Internal light •
- Pyrolytic self-clean •
- True convection •

Oven performance

- Main oven - True convection 2500W

Power requirements

- Supply frequency 60Hz
- Supply voltage 120 - 240V

Product dimensions

- Depth 29 $\frac{1}{8}$ "
- Height 35 $\frac{3}{4}$ " - 36 $\frac{3}{4}$ "
- Width 47 $\frac{7}{8}$ "

Rangetop features

- Gentle heat 3 settings (111°F, 158°F, 201°F)
- Heat settings 9
- Induction cooking technology •
- PowerBoost •
- Sealed Dual Flow Burners™ 4
- Sealed range top •
- Simmer on all burners 140°F
- SmartZone 2
- Vent trim included Flat vent trim
- Zone bridging •

Rangetop Performance

- Left front zone rating 2100W/37000W
- Left rear zone rating 2100W/37000W
- Max burner power 23500BTU
- Power back left 18500BTU
- Power back right 18500BTU
- Power front left 23500BTU
- Power front right 18500BTU
- PowerBoost all zones up to 3700W
- Right front zone rating 2100W/37000W
- Right rear zone rating 2100W/37000W
- Total cooktop power 79000BTU

Safety

- Pan detection system •
- Safety time out •
- Surface hot indicators •

Secondary oven features

- Capacity total (AHAM) 2.1
- Capacity usable (AHAM) 1.8cu ft
- Shelf positions 5

Secondary oven functions

- Bake 2450W
- Broil 3600W
- Convection bake •
- Convection broil •
- Number of secondary oven 11

WarrantyParts and labor **Limited 2 Years Parts & Labor**

SKU 81890

TEST The product dimensions and specifications in this page apply to the specific product and model. Under our policy of continuous improvement, these dimensions and specifications may change at any time. You should therefore check with Fisher & Paykel's Customer Care Centre to ensure this page correctly describes the model currently available. ? Fisher & Paykel Appliances Ltd 2020

Other product downloads available at fisherpaykel.com

- [↓](#) User Guide
- [↓](#) Guide D'Utilisation
- [↓](#) Service & Warranty Booklet
- [↓](#) Installation Guide
- [↓](#) Guide D'Installation
- [↓](#) Resources (zip)

**A PEACE OF MIND SALE****24 Hours 7 Days a Week Customer Support****T 1.888.936.7872 W www.fisherpaykel.com**