

# Oven, 24", 11 Function, Self-cleaning

Series 9 | Contemporary

Stainless Steel



With a subtle black glass finish, this contemporary-style oven has multiple functions to ensure every dish is cooked to perfection.

- Three cubic feet total capacity with eleven oven functions including Aero™ Pastry, Roast and Rapid Proof
- Self-cleaning function breaks down food residue for an easy clean
- Moisture control and even heat distribution thanks to ActiveVent™ and AeroTech technology
- Non-tip, full-extension sliding shelves for safe removal of hot dishes

## DIMENSIONS

Height	23 <sup>9</sup> / <sub>16</sub> "
Width	23 <sup>1</sup> / <sub>2</sub> "
Depth	22 <sup>1</sup> / <sub>4</sub> "

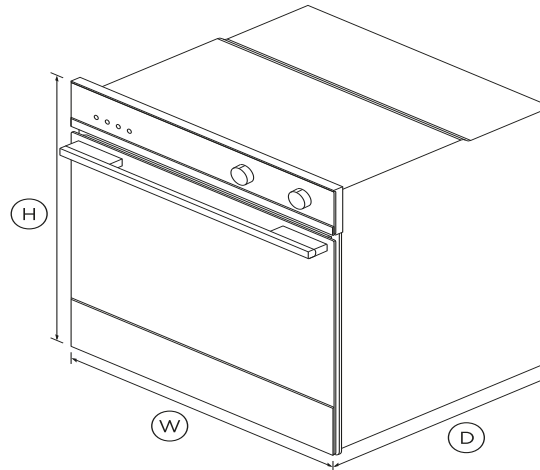

## FEATURES & BENEFITS

### Generous capacity

With a generous sized internal cavity, you can create several dishes at once using multiple shelves.

### Perfect Results

Our built-in ovens feature ActiveVent technology for optimized moisture levels, and AeroTech™ for even heat distribution. Get perfect results even when you're using multiple shelves.

### Multi-function flexibility

11 functions including Aero™ Pastry, Roast and Rapid Proof mean no matter what you're cooking, you've got the right heat to match.

### Seamless fit

Designed to fit seamlessly in your kitchen, this built-in oven fits flush with cabinetry to minimize gaps and add to a cohesive aesthetic.

### Cleaning is simple

The self-clean function breaks down food residue at a very high temperature, leaving a light ash that's easily removed with a damp cloth.

### Refined styling

With sophisticated handle styling and elegant black or stainless steel finish, our built-in ovens are designed to match the rest of Fisher & Paykel's kitchen appliance family.

### Safe and sound

The CoolTouch door features triple glazing and a cooling system that ensures it's safe to touch from the outside – protecting both your hands and the surrounding cabinetry.

## SPECIFICATIONS

### Accessories

Food probe	•
Meat probe	•
Pyrolytic proof shelf runners	1 set
Step down wire shelf	•

### Capacity

Shelf positions	6
Total capacity	3 cu ft
Usable capacity	2.5 cu ft

**Cleaning**

- Acid resistant graphite enamel •
- Pyrolytic proof shelf runners •
- Removable oven door •
- Removable oven door inner •
- Removable shelf runners •
- Self-clean •

**Controls**

- Audio feedback •
- Automatic cooking/minute •
- Automatic pre-set •
- Behind glass capacitive touch •
- Celsius/Fahrenheit •
- Electronic capacitive touch •
- Electronic clock •
- Electronic oven control •
- Interior light **2 x 25W (halogen)**
- Precise electronic temperature •
- Sabbath mode •

**Functions**

- Aero Bake •
- Aero Broil •
- Bake •
- Broil •
- Maxi Broil •
- Number of functions **11**
- Rapid proof •

- Roast •
- Self-clean function •
- True Aero •
- Vent bake •
- Warm •

**Performance**

- ActiveVent™ system •
- AeroTech™ technology •
- Automatic rapid pre-heat •
- Broil power **3000W**
- Whisper quiet cooking •

**Power requirements**

- Amperage **19A**
- Supply frequency **60Hz**
- Supply voltage **208 - 240V**

**Product dimensions**

- Depth **22 1/4 "**
- Height **23 9/16 "**
- Width **23 1/2 "**

**Safety**

- Advanced cooling system •
- Balanced oven door •
- Catalytic venting system •
- Control panel key lock •
- Non-tip shelves •

**Warranty**

Parts and labor **2 years**

SKU 81205

TEST The product dimensions and specifications in this page apply to the specific product and model. Under our policy of continuous improvement, these dimensions and specifications may change at any time. You should therefore check with Fisher & Paykel's Customer Care Centre to ensure this page correctly describes the model currently available. ? Fisher & Paykel Appliances Ltd 2020

---

Other product downloads available at [fisherpaykel.com](http://fisherpaykel.com)

- [↓](#) User Guide
- [↓](#) Service & Warranty Booklet
- [↓](#) Guide D'Utilisation
- [↓](#) Installation Guide
- [↓](#) Guide D'Installation
- [↓](#) Resources (zip)



**A PEACE OF MIND SALE**

24 Hours 7 Days a Week Customer Support

T 1.888.936.7872 W [www.fisherpaykel.com](http://www.fisherpaykel.com)