

ELICA'S EXCLUSIVE PLUS FEATURES

Palermo provides professional grade performance, while it's 28 1/4" & 34 1/5" width models with 10 3/4" depth enables it to be discreetly installed within standard 12" deep cabinetry, making it ideal for smaller kitchens or where the range hood needs to be out of sight. Palermo has a powerful 600 CFM blower to support most cooking needs. Stylish stainless steel push button controls operate a 3-speed blower and LED lighting.

Easy maintenance, higher efficiency and a cleaner kitchen are ensured by Elica's Baffle Slot Filters, which capture a higher percentage of grease and hold larger volumes of grease than traditional baffle filters. Palermo is designed for both ducted out or recirculating installations.

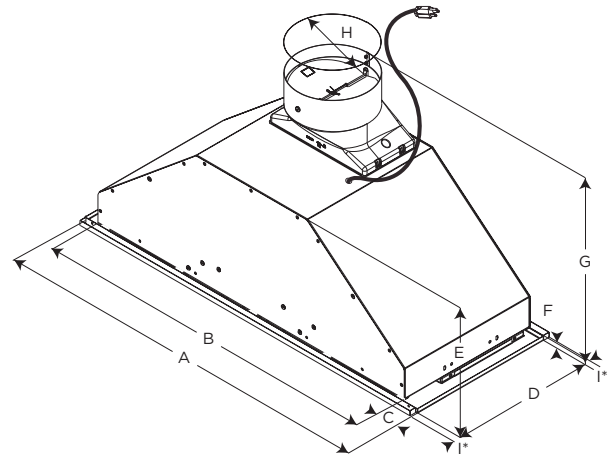

	Model	
	EPR628S1	EPR634SS
<b>A</b>	28 1/4" (71.8 cm)	34 1/4" (86.9 cm)
<b>B</b>	26" (66 cm)	
<b>C</b>	1 9/64" (2.9 cm)	
<b>D</b>	10 3/4" (27.3 cm)	
<b>E</b>	9 7/32" (24.2 cm)	
<b>F</b>	0 2/64" (.85 cm)	
<b>G</b>	14 9/16" (37 cm)	
<b>H</b>	6" (15.2 cm)	
<b>I*</b>	1/2" (127 cm)	



MOUNTING  
HEIGHT  
RANGE

SPECIFICATIONS

Width:	28" UNIT	34" UNIT
Model:	EPR628S1	EPR634SS
Dimensions:	28 1/4"W x 10 3/4"D x 14 9/16" H	34 1/4"W x 10 3/4"D x 14 9/16" H
Blower Type(internal):**	600 CFM, 3-Speed Internal	
Noise (sones):**	6.8 Sones	
Finish:	Stainless Steel	
Controls:	Stainless Steel Push Buttons	
Illumination:	2 LED, 2.1 W, 4000 Kelvin	
Grease Filter:	Dishwasher-Safe, Stainless Steel Baffle slot	
Installation Type:	Ducted or Recirculating (Kit sold separately)	
Duct Transition:	6" Round with Back Draft Damper (top)	
Electrical:	120V-60Hz, 455 W	
KITS:		
Recirculating Kit:	KIT02770 (Contains 2 Round Carbon Filters and cabinet grate)	
CFM Reduction Kit:	KIT02748 (Achieves <300 CFM)	
Optional 30" Hood Liner:	KIT02773 (29" W x 17 1/2" - 20 1/2"D x 4"H)	Not applicable
Optional 36" Hood Liner:	KIT02774 (35" W x 17 1/2" - 20 1/2"D x 4"H)	Not applicable
WARRANTY:***	Two (2) Years Parts & In-Home Labor. Earn an additional One (1) Year of Parts & In-Home Labor by registering on elica.com.	

PLUS FEATURES



**HUSH SYSTEM** - An exclusive sound deadening technology that effectively reduces sound levels up to 35%, compared to typical range hoods.



**LED LIGHT** - LED lighting is undoubtedly the smartest solution in terms of energy saving. Expected life is over 20,000 hours, and should last the full life of the hood.



**TOP PERFORMANCE** - Excellent performance for models equipped with this plus. High fume capturing capacity with an average aspiration range of 600 CFM's. with low noise levels, 1.2 - 1.7 sones at working speed.



**STAINLESS STEEL BAFFLE SLOT FILTERS** - A baffle shaped stainless steel filter with mesh backing allows air to pass but blocks grease, which drops into the high capacity baffle cavities. The design delivers large volume capacity, excellent capture efficiency at ALL blower speeds, silent operation, plus, durability that will last the life of the hood.

Width	HVI Certified Ratings	High Speed	Working Speed	Duct Size
28"	CFM	480	180	6" (Vertical)
	Sones	10	2	6" (Vertical)
34"	CFM	350	100	6" (Vertical)
	Sones	8	0.5	6" (Vertical)

\* The product images shown are for illustration purposes only and may not be an exact representation of the product.

\*\* Blower performance indicates the performance of the blower by itself. Performance claims are not HVI certified but were established in accordance with HVI Standardized test procedure. For Certified Ratings, please refer to HVI Certified Product Directory. Electric Ratings are declared according to UL.

\*\*\* For valid warranty extension, register within 3 months from purchase. For USA & Canada Users Only.