



- CFM REDUCTION
- DIM LIGHT
- HUSH SYSTEM
- TOP PERFORMANCE
- TOUCH CONTROL
- LED LIGHT

ELICA'S EXCLUSIVE PLUS FEATURES

Como combines arched glass wings and stainless steel to create a light and airy environment and being the perfect centerpiece for any contemporary kitchen.

This gently flowing design is powered by a 600 CFM blower that can handle the demands generated by today's cooktops. Como is equipped with glass touch controls, LED dimmable lighting and dishwasher-safe stainless steel microhole filter.

Designed for standard ducted installation, Como can also be installed as a recirculating system using the recirculating kit, available as an accessory.

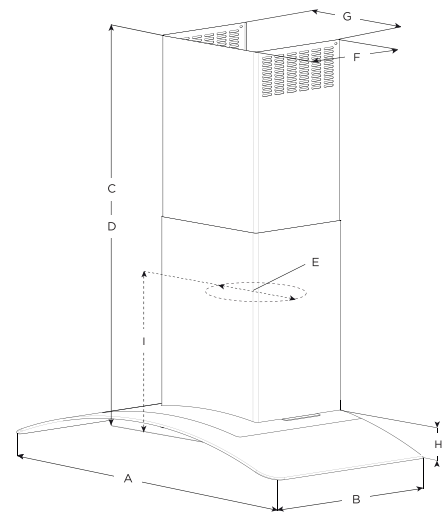

- ≥24"
- ≥30"

MOUNTING  
HEIGHT  
RANGE

	ECM630S3	ECM636S3
<b>A</b>	30" (76.2 cm)	36" (91.4 cm)
<b>B</b>	19 <sup>1</sup> / <sub>16</sub> " (50 cm)	
<b>C*</b>	Max: 54 <sup>1</sup> / <sub>16</sub> " (137.6 cm) Min: 33 <sup>1</sup> / <sub>32</sub> " (84.7 cm)	
<b>D**</b>	Max: 50 <sup>3</sup> / <sub>16</sub> " (127.8 cm) Min: 29 <sup>1</sup> / <sub>16</sub> " (75.4 cm)	
<b>E</b>	6" (15.24 cm)	
<b>F</b>	10 <sup>3</sup> / <sub>4</sub> " (27.3 cm)	
<b>G</b>	13" (33.1 cm)	
<b>H</b>	3 <sup>23</sup> / <sub>32</sub> " (9.4 cm)	
<b>I</b>	12 <sup>5</sup> / <sub>32</sub> " (39.7 cm)	

\* Ductless (Recirculating) version  
\*\* Ducted version

SPECIFICATIONS

Width:	30" UNIT	36" UNIT
Model:	ECM630S3	ECM636S3
Dimensions:	30"W x 19 11/16"D x min:29 11/16" max: 54 1/6"H	36"W x 19 11/16"D x min:29 11/16" max: 54 1/6"H
Blower Type(internal):**	600 CFM, (3-Speed + boost)	
Noise (sones):**	6.8 Sones	
Finish:	Stainless Steel with Black Tempered Glass	
Controls:	Capacitive Touch (Glass)	
Illumination:	2 Premium Dimmable LED Lights, 2.1 W, 4000 K	
Grease Filter:	Dishwasher-Safe, Anodized Stainless Steel Microhole filter	
Duct Transition:	Round 6" Top Discharge	
Installation Type:	Ducted or Recirculating (Kit sold separately)	
Telescopic Chimney:	Can reach ceiling heights of min 7'16", max 10'2" (ducted out) & min 7'10", max 10'5" (recirculating).	
Electrical:	120 V, 60 Hz, 395 W	
KITS:		
Recirculating Kit:	KIT02766 (Contains 6" Deflector and 2 Round Carbon Filters)	
Long Chimney Extension:	KIT0100315 (Can reach 8'5" - 12'1" (ducted), 9'1" - 12'5" (recirculating))	
Charcoal filter Kit:	KIT02667 (Contains 1 filter)	
WARRANTY:***	Two (2) Years Parts & In-Home Labor. Earn an additional One (1) Year of Parts & In-Home Labor by registering on elica.com.	

PLUS FEATURES

- CFM REDUCTION** - CFM Reduction System (CRS), is an exclusive feature to Elica hoods, which enables the user to reduce the maximum blower CFM, to meet local code requirements.
- HUSH SYSTEM** - An exclusive sound deadening technology that effectively reduces sound levels up to 35%, compared to typical range hoods.
- ELECTRONIC TOUCH CONTROLS** - Enjoy the modern design and convenience of multi-function electronic touch controls, which are discreetly hidden behind sleek black glass, and will illuminate a soft blue when activated.
- LED LIGHT** - LED lighting is undoubtedly the smartest solution in terms of energy saving. Expected life is over 20,000 hours, and should last the full life of the hood.
- TOP PERFORMANCE** - Excellent performance for models equipped with this plus. High fume capturing capacity with an average aspiration range of 600 CFM's, with low noise levels, 1.2 - 1.7 sones at working speed.
- DIM-LIGHT** - The Dimmer allows you to adjust the brightness of the light as you wish. With Elica, lighting is customized in a discreet, personal and practical way, in order to contribute in creating the perfect kitchen atmosphere.



Certified Ratings	High Speed	Working Speed	Duct Size
CFM	350	150	6" (Vertical)
Sones	10	2	6" (Vertical)

\* The product images shown are for illustration purposes only and may not be an exact representation of the product.  
 \*\* Blower performance indicates the performance of the blower by itself. Performance claims are not AHAM certified but were established in accordance with HVI Standardized test procedure. For Certified Ratings, please refer to AHAM Certified Product Directory. Electric Ratings are declared according to UL.  
 \*\*\* For valid warranty extension, register within 3 months from purchase. For USA & Canada Users Only.