

COMFORT SERIES  
**VOLTERRA**



3X LAYER  
MESH FILTER



LED LIGHT



CRS  
CFM REDUCTION

ELICA'S EXCLUSIVE  
PLUS FEATURES

Volterra, with its pyramid shaped angles and stainless steel finish, makes a striking visual statement to any kitchen. Available in 30" or 36" widths, Volterra features multiple backlight color touch controls that illuminate in elegant white, green, blue or red, LED lighting and 4-speed blower. It also features a telescopic chimney for up to 9'2" ceilings. Multiple clicking sound options are also available.

Designed for standard ducted installation Volterra can also be installed as a recirculating system using the kit available as an accessory.

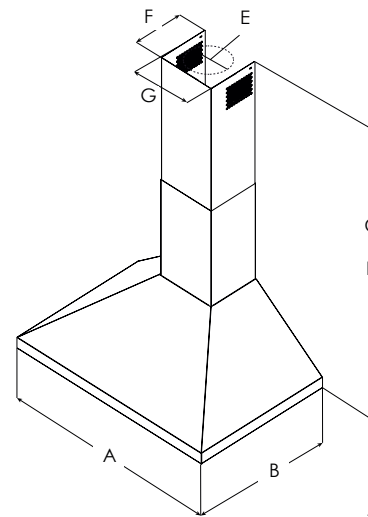

\*Ductless version  
(Recirculating)  
\*\*Ducted version



	EVL430S3	EVL436S3
A	30" (76.2 cm)	36" (91.4 cm)
B	19 1/16" (50 cm)	
C*	Max: 42 1/8" (107 cm) Min: 28 3/8" (72 cm)	
D**	Max: 38 3/16" (97 cm) Min: 28 3/8" (72 cm)	
E	6" (15.24 cm)	
F	7 3/16" (18.3 cm)	
G	8 3/16" (20.8 cm)	

COMFORT SERIES  
**VOLTERRA**



SPECIFICATIONS



Width:	30" Unit	36" Unit
Model:	EVL430S3	EVL436S3
Dimensions:	30"Wx 19 11/16"D x Min:28 3/4" Max: 41 1/8 "H   36"Wx 19 11/16"D x Min:28 3/4" Max: 41 1/8 "H	
Blower Type(internal):**	400 CFM(4-speed)	
Noise (sones):	5.9 Sones	
Finish:	Stainless Steel	
Controls:	Stainless steel look, Multiple backlight color touch controls	
Illumination:	2 LED Lights , 2.1 W 3000 K	
Grease Filter:	Dishwasher-Safe, Anodized Aluminum Mesh Filter 2 for 30" & 3 for 36"	
Duct Transition:	6" Round with BackDraft Damper (top only)	
Installation Type:	Ducted or Recirculating (Kit sold separately)	
Telescopic Chimney:	Can reach ceiling heights For heights 7'5" - 9'1" (ducted), 7'5" - 9'6" (recirculating)	
Electrical:	120V - 60 Hz, 265 watts	
KITS:		
Chimney Extension Kit:	KIT02762 (Reaches ceiling heights of 8'5" - 11'3" (ducted), 8'6" - 11'7" (recirculating)	
Recirculating Kit:	KIT02766 (contains 6" deflector and 2 round carbon filters)	
Upgrade Filter Kit:	GF04YB (Stainless Steel Microhole Filter – contains 1 filter)	
WARRANTY:***	Two (2) Years Parts & In-Home Labor. Earn an additional One (1) Year of Parts & In-Home Labor by registering on elica.com.	

PLUS FEATURES



**3X LAYER GREASE FILTER** - Elica aluminum mesh filters are a step above competition, featuring triple layered, anodized aluminum that is woven into a highly dense mesh. The thick mesh captures more grease, anodization helps resist staining and provides durability to repeated cleanings in the dishwasher.



**LED LIGHT** - LED lighting is undoubtedly the smartest solution in terms of energy saving. Expected life time of over 20.000 hours, and should last the full life of the hood.



**CFM REDUCTION** - CFM Reduction System (CRS), is an exclusive feature to Elica hoods, which enables the user to reduce the maximum blower CFM, to meet local code requirements.

HVI Certified Ratings	High Speed	Working Speed	Duct Size
CFM	350	100	6" (Vertical)
Sones	8	1	6" (Vertical)

\* The product images shown are for illustration purposes only and may not be an exact representation of the product.

\*\* Blower performance indicates the performance of the blower by itself. Performance claims are not HVI certified but were established in accordance with HVI Standardized test procedure. For Certified Ratings, please refer to HVI Certified Product Directory. Electric Ratings are declared according to UL.

\*\*\* For valid warranty extension, register within 3 months from purchase. For USA & Canada Users Only.