

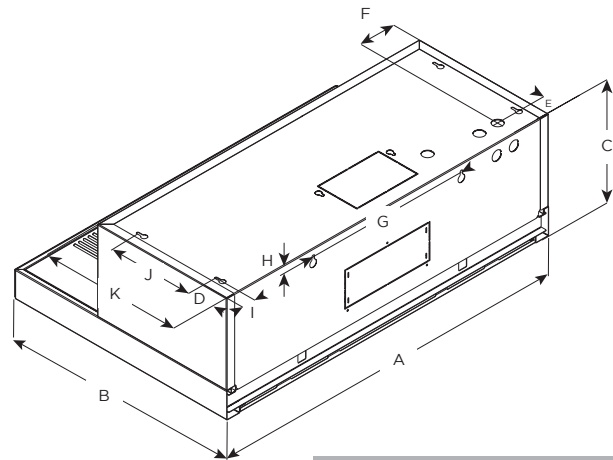

ELICA'S EXCLUSIVE PLUS FEATURES

Modena offers a classic designer chimney appearance for under-cabinet installations, with a striking 9" high pyramid shape. Modena also provides high-end features not commonly found in under-cabinet hoods, including 520 CFM blower, LED dimmable lighting, stainless steel microhole filters and easy to use glass capacitive touch controls that deliver convenience and safety.

Available in 30" or 36" width, and designed for standard ducted installation, Modena can also be installed as a recirculating system using the kit available as an accessory. For design versatility to suit almost any kitchen.



| | Models | |
|---|---|---|
| | EMD530S3 | EMD536S3 |
| A | 30" (76 cm) | 36" (91.2 cm) |
| B | 19 ⁵ / ₈ " (50 cm) | |
| C | 9 ³ / ₄ " (25 cm) | |
| D | 2 ³ / ₁₆ " (5.5 cm) | |
| E | 1 ¹ / ₁₆ " (4 cm) | |
| F | 3" (7.6 cm) | 5 ³ / ₄ " (14.6 cm) |
| G | 13 ¹ / ₁₆ " (35 cm) | |
| H | 5 ⁸ / ₈ " (1.6 cm) | |
| I | 1 ¹ / ₁₆ " (3 cm) | |
| J | 7 ¹ / ₄ " (18.4 cm) | |
| K | 12" (30.5 cm) | |



MOUNTING HEIGHT RANGE

For gas range installation: Mount this hood so that the bottom edge is at minimum 27"(68.6 cm) above the cooking surface. For electric range installation: mount this hood so that the bottom is not less than 24"(61 cm).

SPECIFICATIONS

| | 30" UNIT | 36" UNIT |
|---------------------------------|--|-------------------|
| Model: | EMD530S3 | EMD536S3 |
| Dimensions: | 30"W x 20"D x 9"H | 36"W x 20"D x 9"H |
| Blower Type(internal): | 520 CFM blower | |
| Blower Performance: | | |
| Speed 1 | 170 CFM | |
| Speed 2 | 280 CFM | |
| Speed 3 | 430 CFM | |
| Speed 4 | 520 CFM | |
| Noise (sones): Working Speed | Min: 1.73, Max: 6 Sones | |
| Finish: | Stainless Steel + Black Glass | |
| Controls: | Touch Control 3S+ Booster | |
| Illumination: | 2 Premium LED Dimmable Lights, 2.5 W | |
| Filter Type: | 2 Dishwasher- Safe, Stainless Steel Microhole Filter | |
| Installation Type: | Ducted or Recirculating with installation Kit (sold separately) | |
| Duct Transition: | 3 1/4" x 10" Rectangular (rear outlet) and 6" Round (top outlet) | |
| Electrical: | 120 Volts, 60 Hertz, 455 Watts, 3.8 Amps | |
| KITS: | | |
| Optional Recirculating Kit | KIT02667 | |

*The product images shown are for illustration purposes only and may not be an exact representation of the product.

PLUS FEATURES



AMBIENT LIGHT - Elica studies on hood lighting leaves no stone unturned. Here we have thought about products not only able to light the cooktop, but the entire kitchen space. And so the hood is transformed: from a kitchen appliance to a true lighting element. Considering the design of Elica hoods, it is not hard to imagine how this option is quite unique, and represents one extraordinary point of strength for us.



LED LIGHT - LED lighting is undoubtedly the smartest solution in terms of energy saving. Expected life time of over 20,000 hours, represents the most remarkable advantage of LED light bulbs.



HUSH SYSTEM - An exclusive sound deadening technology that effectively reduces sound levels up to 35%, compared to typical range hoods.



DIM-LIGHT - The Dimmer allows you to adjust the brightness of the light as you wish. With Elica, lighting is customized in a discreet, personal and practical way, in order to contribute in creating the perfect kitchen atmosphere.



CFM REDUCTION - CFM Reduction System (CRS), is an exclusive feature to Elica hoods, which enables the user to reduce directly in the glass touch control the maximum blower CFM, to meet local code requirements.



ELECTRONIC TOUCH CONTROLS - Enjoy the modern design and convenience of multi-function electronic touch controls, which are discreetly hidden behind sleek black glass, and will illuminate a soft blue when activated.