

# PTB83 | PRO Collection

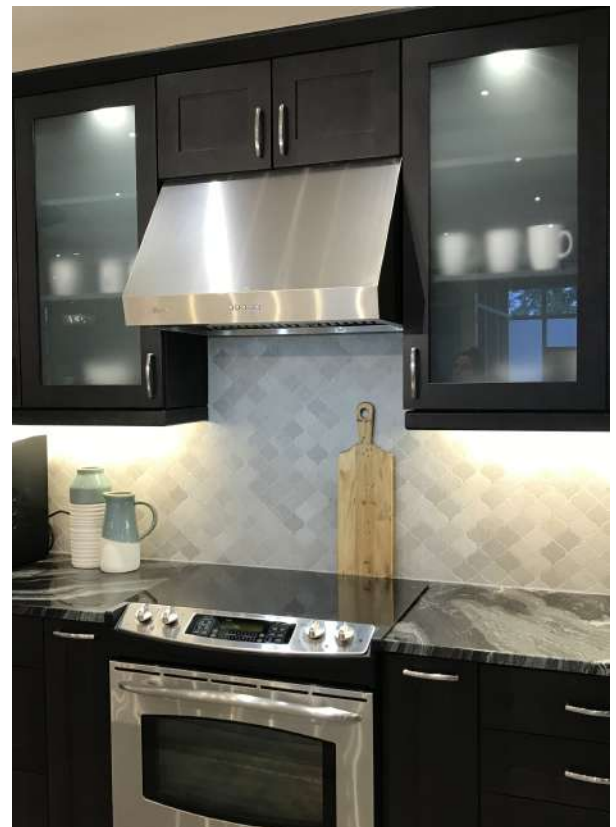

## Undermount

Cyclone is excited to introduce its grandest undermount ever. Perfect for high-heat cooking. The PTB83 has an incredible 3-speed 300 CFM fan wrapped in an imposing 18" tall wall-mount style stainless steel body. Quickly rid your kitchen of smoke and grease. Comes with durable and dishwasher-friendly baffle filters, 3 bright LED lights and a 6" duct connection for optimal performance and convenient installation, all backed by the best warranty in the business.



## Green Features



3 Speed  
Push Button  
Control Panel



Dishwasher Safe  
Baffle Filters



Time-Delay  
OFF Feature



Grease Cup



Long-Lasting  
LED Lights



Grease Tray

Model	Colour	Ducting	Filters	Size	CFM
PTB8324	Stainless Steel	6"	Baffle	24"	300

Cyclone Range Hoods Inc.

1361 Huntingwood Drive, Unit 16, Toronto, ON, M1S 3J1, Canada.

Toll Free: 1-888-293-5662 Tel: (416) 293-0933 Fax: (416) 293-4793 Website: [www.CycloneRangeHoods.com](http://www.CycloneRangeHoods.com)

## Features

- Undermount range hood
- 6" round duct adapter
- Non-stick aluminum fan blades
- 3 speed push button control
- 3 LED lights (3 x 1.4W, 4000K)
- Dishwasher-safe baffle filters with integrated handles
- 3 minutes time-delay OFF feature
- Plug-in connection

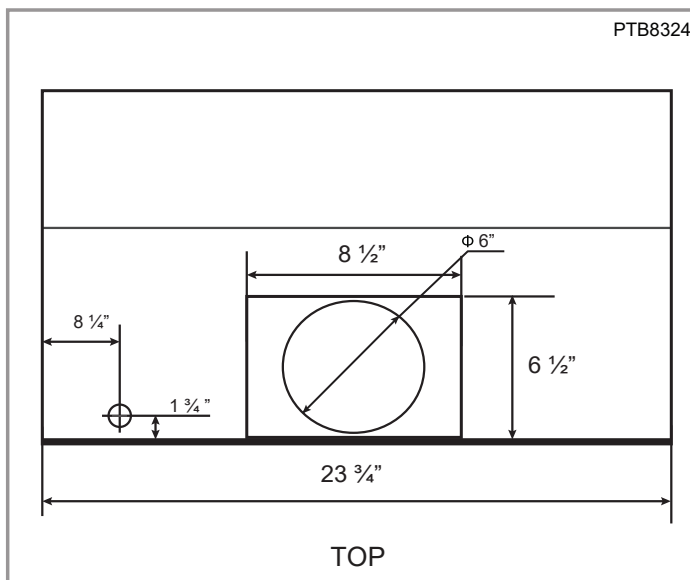
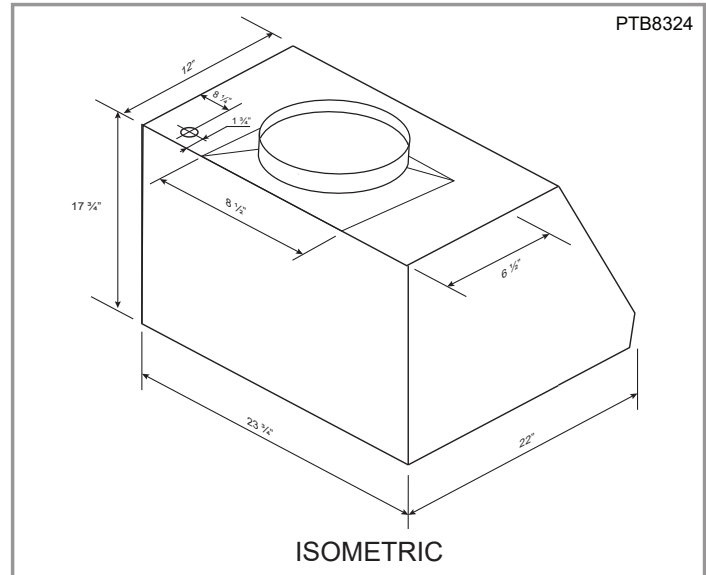

## Options

- Chimney Flues:
  - TBD - short (8' ceilings)
  - TBD - extended (9' ceilings)
- Widths: 24" only

## Specifications

- |                                      |                                |   |
|--------------------------------------|--------------------------------|---|
| ▪ Air Flow Volume: 300 CFM           | ▪ Current: 2.5 Amps            | ▪ Finishes: Stainless Steel                 |
| ▪ Electrical Connection: 120 V/60 Hz | ▪ Fan Speed: 1350 RPM          | ▪ Ducting: 6" Round                         |
| ▪ Power Consumption: 300 Watts       | ▪ Fan Type: Centrifugal Blower | ▪ Noise Level: Min. 2 Sones<br>Max. 4 Sones |

