



in (mm)

**en-us** Installation Instructions  
**fr-ca** Instructions d'installation  
**es-mx** Instrucciones de instalación



---

**en-us** Available from our Customer Service  
**fr-ca** disponible via le service après-vente  
**es-mx** disponible a través del Servicio de atención al cliente

9002033327 (051205)





## IMPORTANT SAFETY INSTRUCTIONS

READ AND SAVE THESE INSTRUCTIONS

2

Observe the following safety instructions.

### WARNING

The appliance is very top-heavy and may tip over.

- ▶ The appliance must be transported by two or more people.
- ▶ Do not remove the appliance from the pallet until it is ready for installation.
- ▶ Keep the doors and drawers closed until the appliance is fully installed.

### WARNING

The heavy weight of the appliance may result in injury when lifted.

- ▶ Do not lift the appliance on your own.

### WARNING

Incorrect installation is dangerous.

- ▶ Connect and operate the appliance only in accordance with the specifications on the rating plate.
- ▶ Connect the appliance to a power supply with alternating current only via a correctly installed socket outlet with grounding.
- ▶ The protective conductor system of the domestic electrical installation must be properly installed.
- ▶ Never equip the appliance with an external switching device, e.g. a timer or remote control.
- ▶ When the appliance is installed, the mains plug of the power cord must be freely accessible. If free access is not possible, an isolating switch must be integrated into the permanent electrical installation according to the installation regulations.



## IMPORTANT SAFETY INSTRUCTIONS

READ AND SAVE THESE INSTRUCTIONS

- ▶ When installing the appliance, check that the power cord is not trapped or damaged.

If the insulation of the power cord is damaged, that can be dangerous.

- ▶ Never let the power cord come into contact with heat sources.

### WARNING

If the appliance's ventilation openings are closed off, a leak in the refrigeration circuit may result in a flammable mixture of gas and air.

- ▶ Keep ventilation openings in the appliance casing or in the integrated casing clear of obstruction.

### WARNING

It is dangerous to use an extended power cord and non-approved adapters.

- ▶ Do not use extension cords or multiple socket strips.
- ▶ Only use adapters and power cords approved by the manufacturer.
- ▶ If the power cord is too short and a longer one is not available, please contact an electrician to have the domestic installation adapted.

Multiple-socket strips or portable power supply units may overheat and cause a fire.

- ▶ Do not place multiple-socket strips or power supply units on the back of the appliance.

### WARNING

The appliance is very top-heavy and may tip over.

- ▶ The appliance must be installed by two or more people as soon as it is no longer secured and is removed from the pallet.



## IMPORTANT SAFETY INSTRUCTIONS

READ AND SAVE THESE INSTRUCTIONS

- ▶ Secure the unit using the supplied anti-tip bracket.
- ▶ Do not leave the appliance unattended during installation.

### CAUTION

Touching sharp edges on the appliance may lead to cuts.

- ▶ Wear protective gloves.

# Preventing material damage

## ***NOTICE:***

The high weight of the appliance or, if not rolled in a straight line, the appliance's castors may damage the floor when the appliance is moved.

- ▶ Transport the appliance using a hand-cart.
- ▶ Use floor protection when moving the appliance, and do not move it in a zigzag fashion.

Using the base, runners or appliance doors as a seat or climbing surface may damage the appliance.

- ▶ Do not stand or lean on the base, runners or doors.

To avoid damage to the appliance or property damage, observe the following.

- ▶ Do not connect the appliance to the water line during construction or if the water appears cloudy or contains visible particles. Failure to follow these instructions may result in foreign materials entering the appliance, which could impair its performance, or cause water leakage.

If the water pressure is too high or too low, this may impair functioning of the appliance.

- ▶ Make sure that the water pressure in the water supply system is at least 29 psi (200 kPa) and max. 116 psi (800 kPa).
- ▶ If the water pressure exceeds the maximum value specified, a pressure-reducing valve must be installed between the drinking water connection and the hose set of the appliance.

Modified or damaged water hoses may result in material damage and damage to the appliance.

- ▶ Never kink, crush, modify or cut through water hoses.
- ▶ Never re-use water hoses that have been used before.
- ▶ Never pull on the water hose on the rear panel of the appliance.



## IMPORTANTES CONSIGNES DE SÉCURITÉ

LIRE ET CONSERVER CES INSTRUCTIONS

6

Respectez les consignes de sécurité suivantes.

### AVERTISSEMENT

L'appareil est très lourd, son poids est inégalement réparti et il peut basculer.

- ▶ L'appareil doit être transporté par deux ou plusieurs personnes.
- ▶ Retirer l'appareil de la palette seulement lorsqu'il est prêt à être installé.
- ▶ Maintenir les portes et les tiroirs fermés jusqu'à ce que l'appareil soit complètement installé.

### AVERTISSEMENT

Il peut être risqué de soulever l'appareil en raison de son poids élevé.

- ▶ Soulevez l'appareil à deux personnes.

### AVERTISSEMENT

Les installations non conformes sont dangereuses.

- ▶ Observer impérativement les indications figurant sur la plaque signalétique lors du raccordement et de l'utilisation de l'appareil.
- ▶ Brancher l'appareil uniquement à l'aide d'une fiche dûment installée avec mise à la terre dans une prise secteur à courant alternatif.
- ▶ Le système à conducteur de protection de l'installation électrique de la maison doit être installé correctement.
- ▶ Ne jamais alimenter l'appareil par l'intermédiaire d'un appareil de commutation externe, par ex. une minuterie ou une télécommande.



## IMPORTANTES CONSIGNES DE SÉCURITÉ

LIRE ET CONSERVER CES INSTRUCTIONS

- ▶ Si l'appareil est encastré, la fiche du cordon d'alimentation secteur doit être librement accessible ou, si un accès libre est impossible, un dispositif de sectionnement doit être installé dans l'installation électrique fixe, conformément aux réglementations d'installation.
- ▶ Veillez à ne pas coincer ou endommager le câble d'alimentation en posant l'appareil.

Le cordon d'alimentation pose un danger si sa gaine de protection est endommagée.

- ▶ Ne mettez jamais en contact le cordon d'alimentation avec des sources de chaleur.

### AVERTISSEMENT

Si les orifices de ventilation de l'appareil sont obstrués, un mélange gaz-air inflammable peut se produire si le circuit de réfrigération fuit.

- ▶ N'obstruez pas les orifices de ventilation dans le boîtier de l'appareil ou dans le boîtier d'installation.

### AVERTISSEMENT

Il est dangereux d'utiliser un cordon d'alimentation rallongé ou un adaptateur non autorisé.

- ▶ Ne pas utiliser de rallonge ni de bloc multiprise.
- ▶ Utiliser uniquement les adaptateurs et cordons d'alimentation secteur autorisés par le fabricant.



## IMPORTANTES CONSIGNES DE SÉCURITÉ

8

LIRE ET CONSERVER CES INSTRUCTIONS

- ▶ Si le cordon d'alimentation secteur est trop court et qu'aucun autre cordon plus long n'est disponible, contacter un électricien spécialisé pour adapter l'installation domestique.

Les blocs multiprises ou blocs secteur mobiles peuvent surchauffer et provoquer un incendie.

- ▶ Ne placez pas les blocs multiprises ou blocs secteur mobiles à l'arrière des appareils.

### AVERTISSEMENT

L'appareil est très lourd, son poids est inégalement réparti et il peut basculer.

- ▶ L'appareil doit être installé par deux personnes ou plus dès qu'il n'est plus sécurisé et qu'il est retiré de la palette.
- ▶ Sécuriser l'appareil à l'aide des arceaux anti-basculement fournis.
- ▶ Surveillez l'appareil pendant son installation.

### MISE EN GARDE

Vous risquez de vous couper en touchant les arêtes vives de l'appareil.

- ▶ Portez des gants de protection.

# Prévenir les bris matériels

## **AVIS :**

Le poids élevé de l'appareil ou le basculement des roulettes de l'appareil risquent d'endommager le sol lors de son déplacement.

- Transportez l'appareil avec un diable.
- Lorsque vous déplacez l'appareil, protégez le sol et ne faites pas de zigzags.

L'utilisation du socle, des glissières ou des portes de l'appareil comme surface d'assise ou comme marchepied peut endommager l'appareil.

- Ne vous servez jamais du socle, des glissières ou des portes comme marchepieds et ne vous appuyez jamais dessus.

Observez les consignes suivantes pour éviter d'endommager l'appareil ou votre propriété.

- Ne raccordez pas l'appareil à la conduite d'eau si des travaux de construction sont en cours ou si l'eau semble trouble ou contient des particules visibles. Négliger ces instructions pourrait entraîner la présence de corps étrangers dans l'appareil, ce qui pourrait en affecter la performance ou causer des fuites d'eau.

Une pression de l'eau trop faible ou trop élevée peut gêner le fonctionnement de l'appareil.

- Assurez-vous que la pression d'eau au niveau de l'alimentation en eau est comprise entre 29 psi (200 kPa) minimum et 116 psi (800 kPa) maximum.
- Si la pression hydraulique excède la valeur maximale indiquée, un réducteur de pression entre le raccord d'eau potable et la trousse de tuyaux de l'appareil doit être installé.

Les tuyaux d'eau modifiés ou endommagés peuvent provoquer des dégâts matériels ou endommager l'appareil.

- Veillez à ne jamais plier, écraser, modifier ou couper les tuyaux d'eau.
- Ne réutilisez jamais des tuyaux d'eau usagés.
- Ne tirez jamais sur le tuyau d'eau ou sur la paroi arrière de l'appareil.



# INSTRUCCIONES DE SEGURIDAD IMPORTANTES

10

LEA Y CONSERVE ESTAS INSTRUCCIONES

Tenga en cuenta las siguientes indicaciones de seguridad.

## ADVERTENCIA

El aparato es muy pesado, con más peso en la parte superior, y se puede volcar.

- ▶ El aparato debe ser transportado por dos o más personas.
- ▶ Retirar el aparato del palet solo cuando esté listo para la instalación.
- ▶ Mantener cerradas las puertas y los cajones hasta que el aparato esté completamente instalado.

## ADVERTENCIA

El elevado peso del aparato podría causar lesiones al levantarlo.

- ▶ Levantar el aparato solamente con ayuda de otra persona.

## ADVERTENCIA

Las instalaciones incorrectas son peligrosas.

- ▶ Conectar y poner en funcionamiento el aparato solo de conformidad con los datos que figuran en la placa de características.
- ▶ Conectar el aparato solo a una fuente de alimentación con corriente alterna a través de una toma de corriente instalada reglamentariamente y provista de puesta a tierra.
- ▶ La conexión de puesta a tierra de la instalación eléctrica doméstica debe estar instalada de acuerdo con las normas vigentes.
- ▶ No alimentar nunca el aparato a través de un dispositivo de conmutación externo, como por ejemplo, un reloj avisador o un mando remoto.



## **INSTRUCCIONES DE SEGURIDAD IMPORTANTES**

LEA Y CONSERVE ESTAS INSTRUCCIONES

- ▶ Cuando el aparato esté montado, el enchufe del cable de conexión a la red debe quedar accesible, o, en caso de que no sea posible, debe haberse instalado un dispositivo de separación en la instalación eléctrica fija según lo dispuesto en las normas de instalación.
- ▶ Al instalar el aparato debe prestarse atención a que el cable de conexión de red no quede atrapado ni se dañe.

Un aislamiento dañado del cable de conexión de red es peligroso.

- ▶ Evite que el cable de conexión de red entre en contacto con fuentes de calor.

### **ADVERTENCIA**

Si las aberturas de ventilación del aparato se encuentran cerradas, puede generarse una mezcla inflamable de aire y gas en caso de una fuga del circuito de enfriamiento.

- ▶ No cerrar las aberturas de ventilación de la carcasa del aparato o de la carcasa de la instalación.

### **ADVERTENCIA**

Utilizar un cable de conexión de red prolongado y adaptadores no autorizados es peligroso.

- ▶ No utilizar cables de prolongación ni regletas de tomas de corriente múltiples.
- ▶ Utilizar solo adaptadores y cables de conexión de red autorizados por el fabricante.



## INSTRUCCIONES DE SEGURIDAD IMPORTANTES

12

LEA Y CONSERVE ESTAS INSTRUCCIONES

- ▶ Si el cable de conexión de red es demasiado corto y no hay disponible ningún cable de mayor longitud, ponerse en contacto con un técnico electricista para adaptar la instalación doméstica.

Las unidades de alimentación o las tomas de corriente múltiples, móviles, pueden sobrecalentarse y provocar incendios.

- ▶ No colocar las unidades de alimentación o las tomas de corriente múltiples móviles en la parte posterior de los aparatos.

### ADVERTENCIA

El aparato es muy pesado, con más peso en la parte superior, y se puede volcar.

- ▶ El aparato debe ser instalado por dos o más personas en cuanto deje de estar asegurado y se encuentre alejado del palet.
- ▶ Asegurar el aparato con la escuadra antivuelco suministrada.
- ▶ Vigilar el aparato durante la instalación.

### PRECAUCIÓN

Los bordes afilados de la unidad pueden causar cortes al tocarla.

- ▶ Llevar guantes protectores.

# Evitar daños materiales

## **AVISO:**

Al desplazar el aparato, debido a su elevado peso o la inclinación de las ruedas del aparato, el piso puede resultar dañado.

- ▶ Transportar el aparato con una carretilla para sacos.
- ▶ Proteger el piso con algo cuando se vaya a desplazar el aparato y no volverlo en zigzag.

Al subirse o apoyarse sobre pedestales, cajones o puertas, se puede dañar el aparato.

- ▶ No pisar ni apoyarse sobre el pedestal, cajones o puertas.

Para evitar daños en el aparato o daños materiales, tenga en cuenta lo siguiente.

- ▶ No conecte el aparato a la línea de agua durante las obras o si el agua está turbia o contiene partículas visibles. El incumplimiento de estas instrucciones puede provocar la entrada de materiales extraños en el aparato, lo que podría perjudicar su funcionamiento o causar fugas de agua.

Una presión de agua demasiado baja o elevada puede influir negativamente en el funcionamiento del aparato.

- ▶ Es preciso asegurarse de que la presión de agua del dispositivo de suministro de agua sea de 29 psi (200 kPa) como mínimo y de 116 psi (800 kPa) como máximo.
- ▶ Si la presión del agua excede el valor máximo indicado, se debe instalar una válvula de reducción de presión entre la toma de agua y el juego de mangueras del aparato.

Las mangueras de agua modificadas o dañadas pueden causar daños a la propiedad o al aparato.

- ▶ No doblar, aplastar, modificar ni cortar las mangueras de agua.
- ▶ No reutilizar nunca las mangueras de agua ya usadas.
- ▶ No jalar nunca la manguera de agua de la parte trasera del aparato.

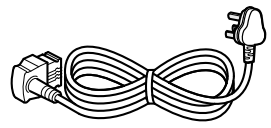
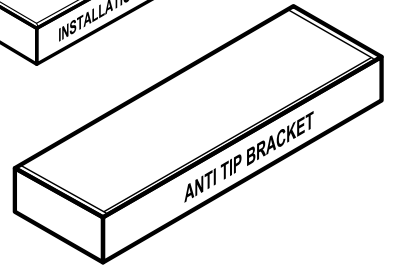
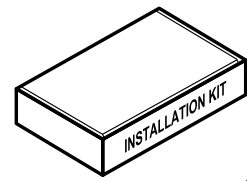
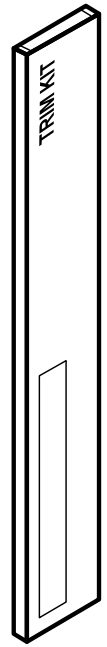
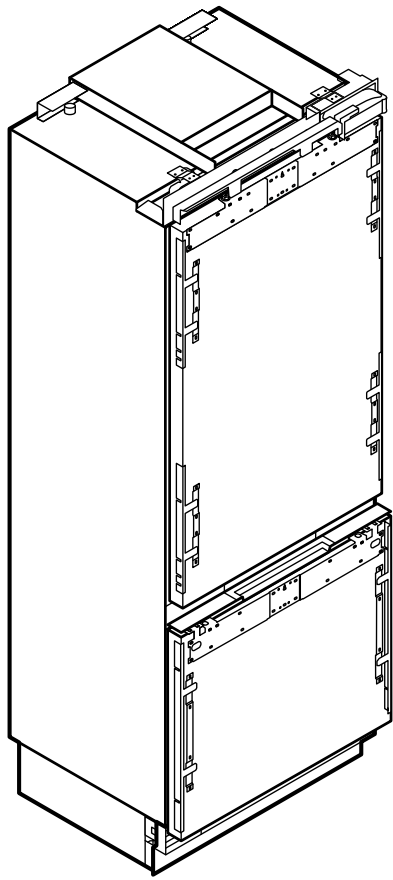
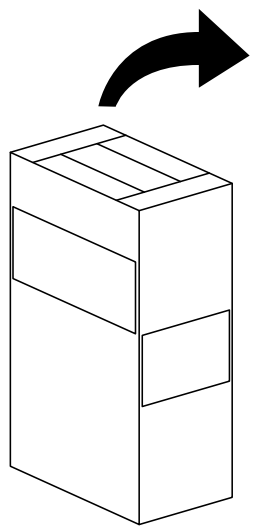

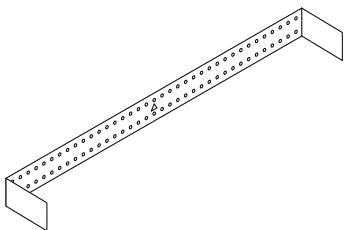
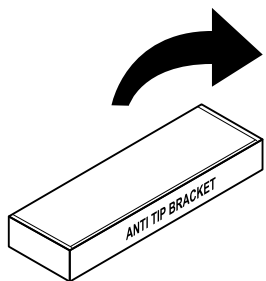

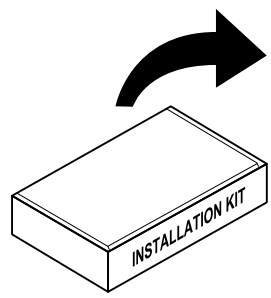

6x31 M5x60 T20  
4x 4x

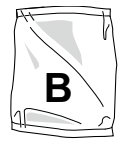

M4.2x6.5 T20  
4x

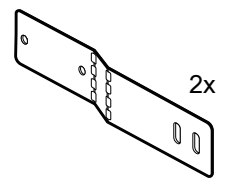

2x



Torx T20  
Torx T20  
2x

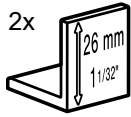

M4x15 T20  
8x



M4x15 T20  
68x



M4x15 T20  
6x

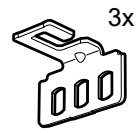

3x

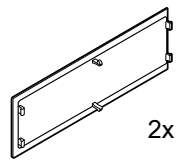

2x



2x



M4x15 T20  
2x

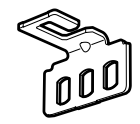

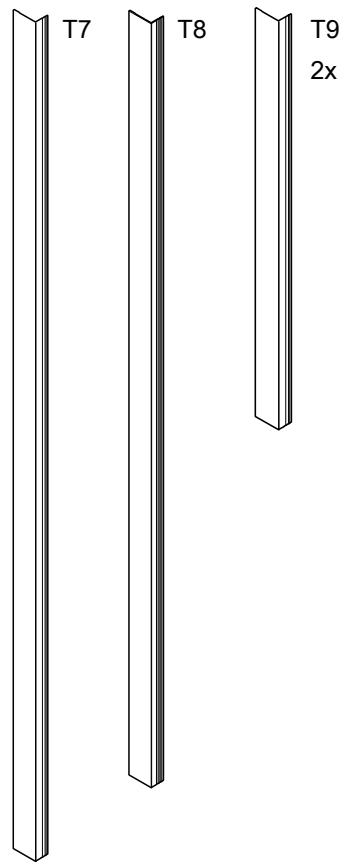
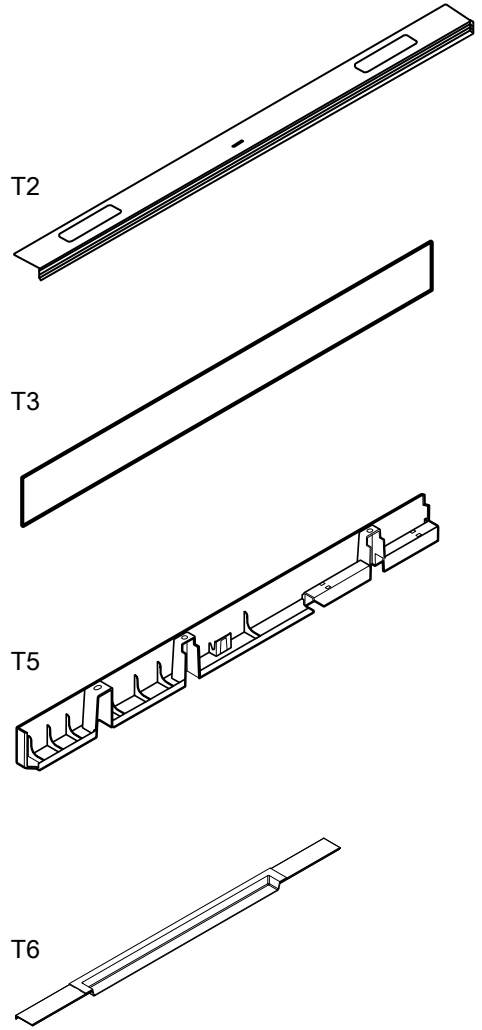
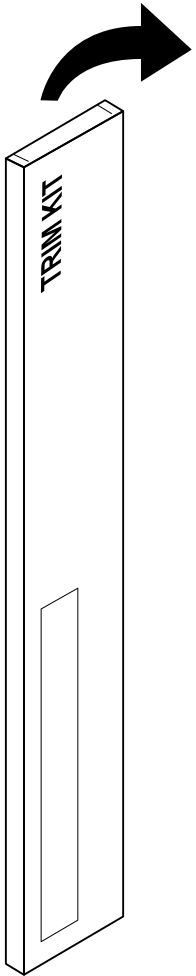

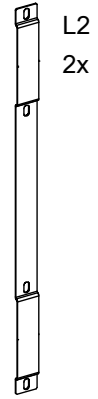
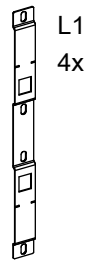
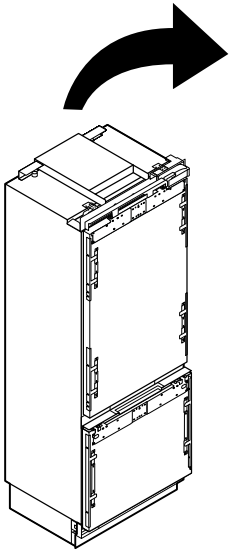

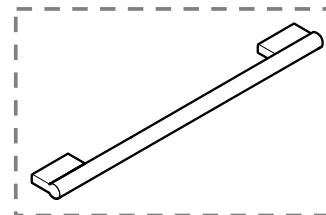
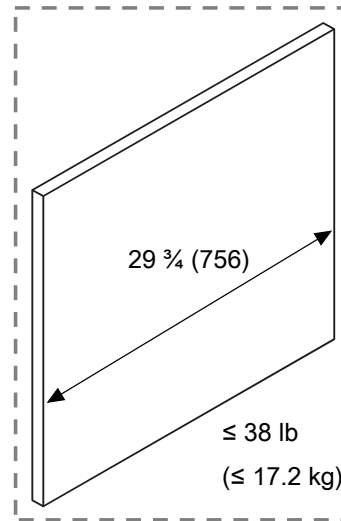
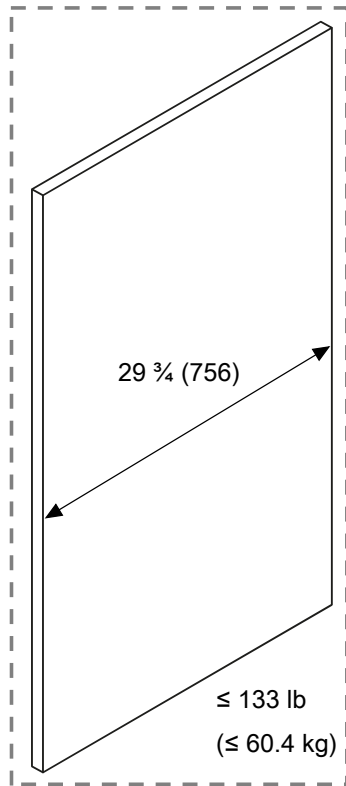

not supplied  
non fourni  
no suministrado

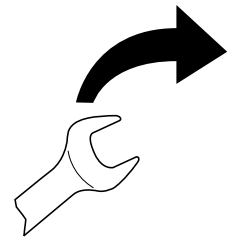

not supplied  
non fourni  
no suministrado

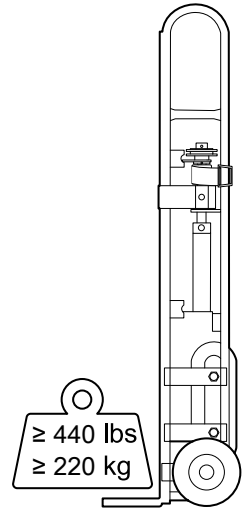
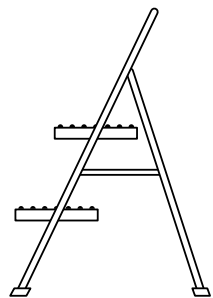
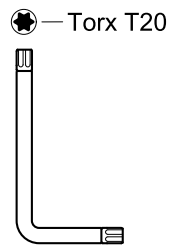
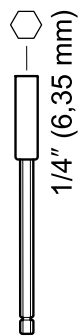
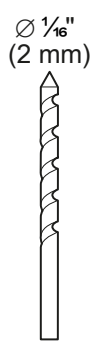
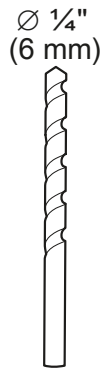
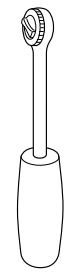
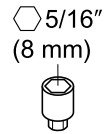
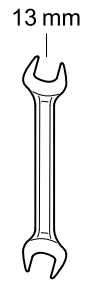
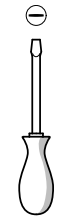
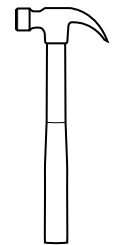
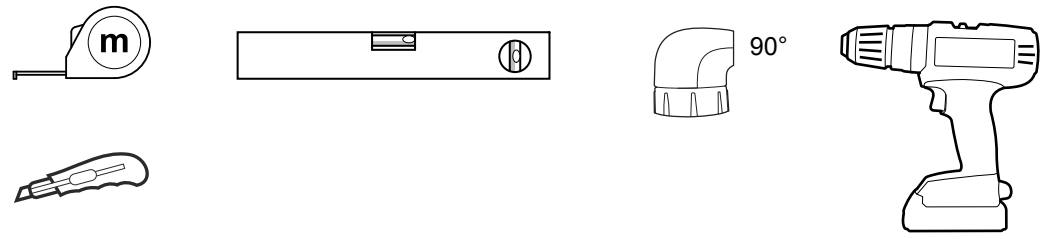

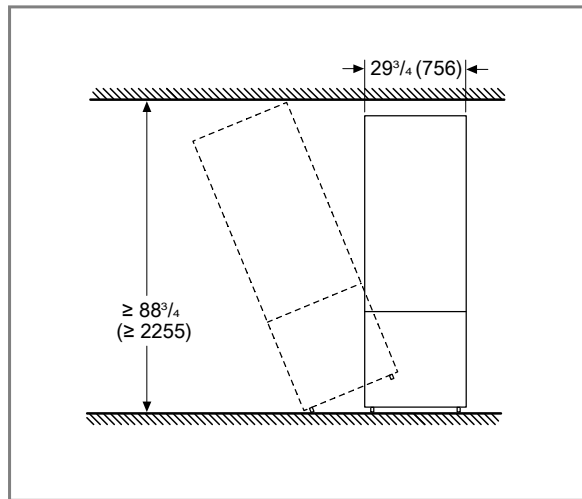
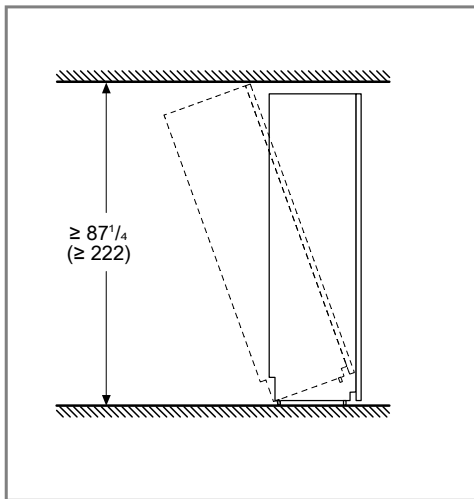
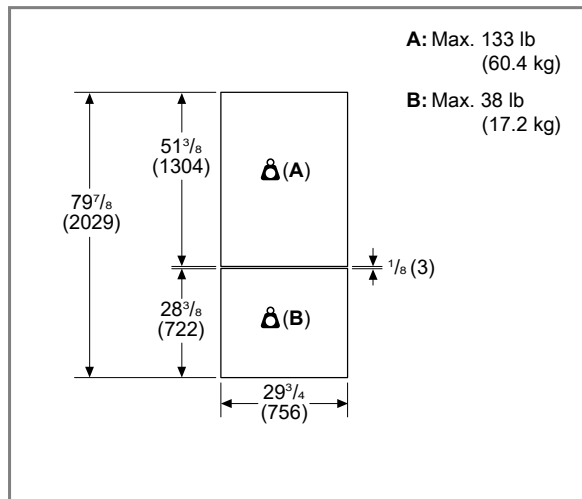
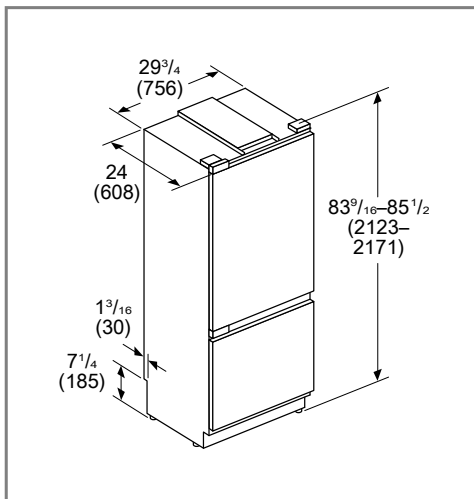
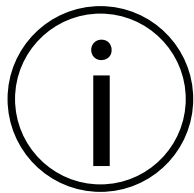



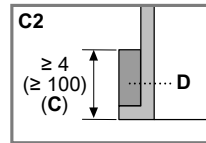
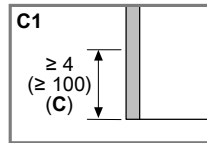
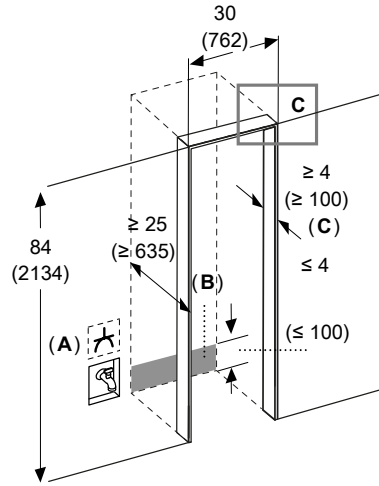
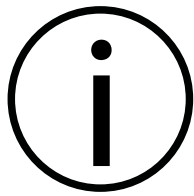

- A:** Socket  
**B:** Area for water and electric line routing
- C:** Furniture return  
C1: Frameless cabinet  
C2: Framed cabinet
- D:** Filler

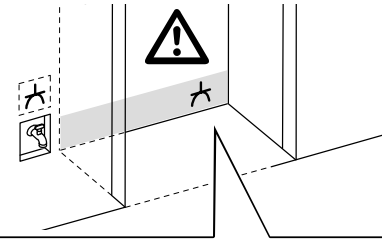

When the appliance is installed, the power plug of the power cord must be freely accessible. If free access is not possible, an all-pole isolating switch must be integrated in the permanent electrical installation according to the installation regulations.

Si l'appareil est encastré, la fiche du cordon d'alimentation secteur doit être librement accessible ou, si un accès libre est impossible, un dispositif de sectionnement tous pôles doit être installé dans l'installation électrique fixe, conformément aux réglementations d'installation.

Quando el aparato esté montado, el enchufe del cable de conexión de red debe quedar accesible, o, en caso de que no pueda quedar accesible, debe instalarse un dispositivo de separación omnipolar en la instalación eléctrica fija, de acuerdo con las normas de instalación.

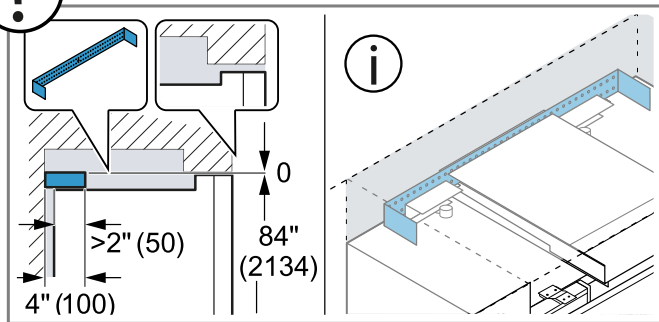
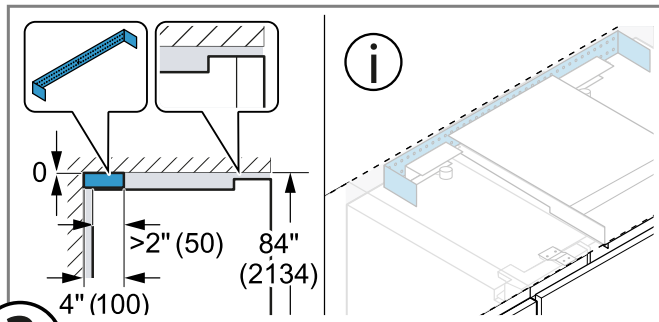
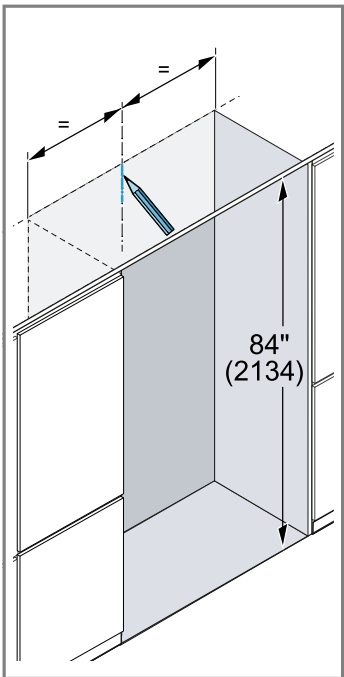
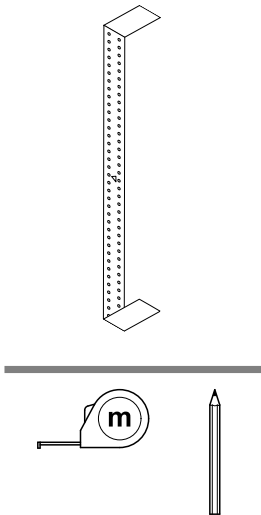
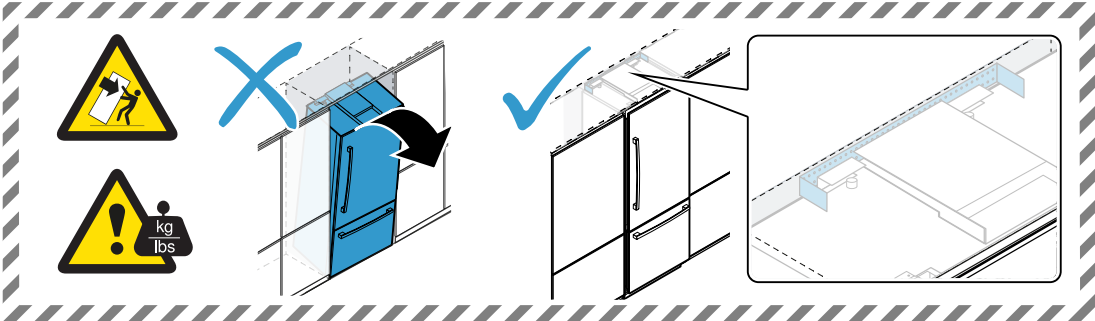

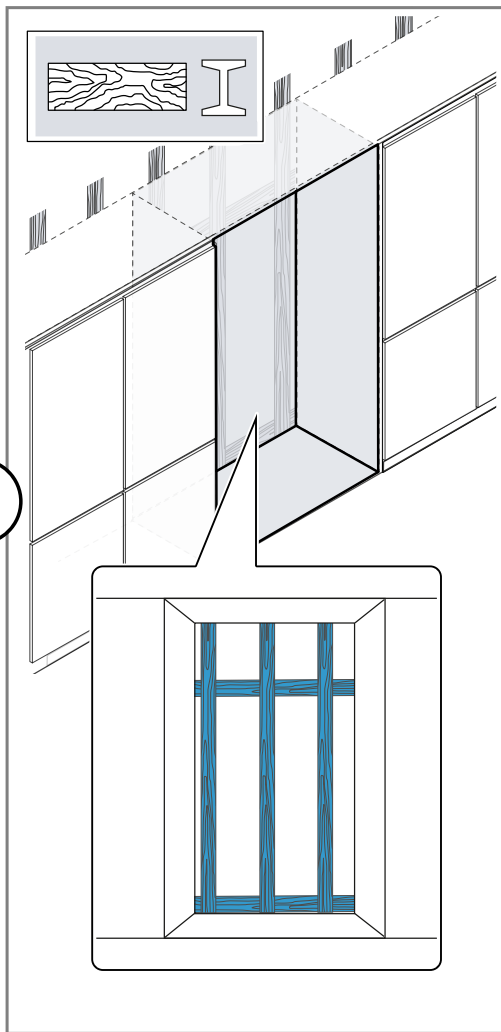
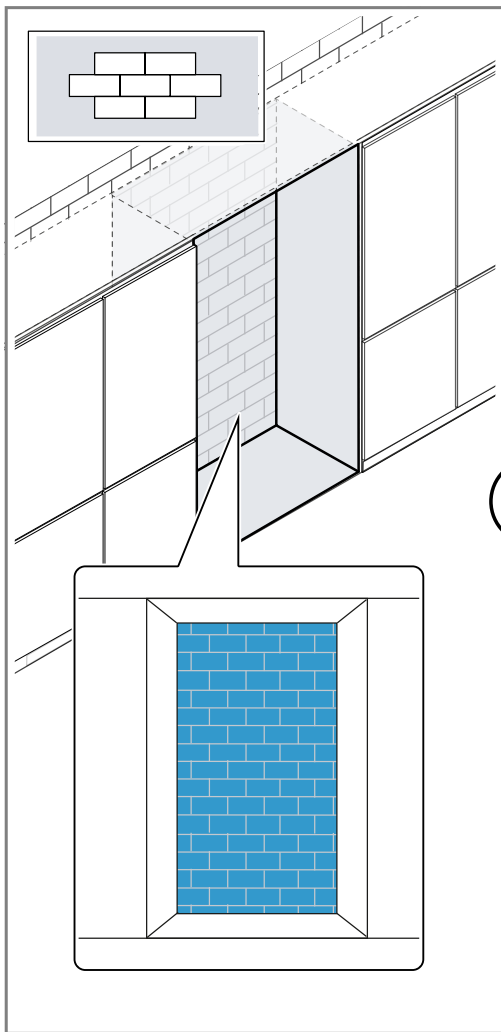
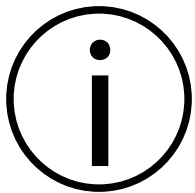



M5x60 T20  
4x

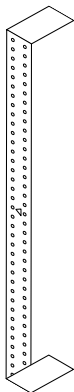

Ø 1/8"  
(2 mm)



Torx  
T 20

— Torx T20

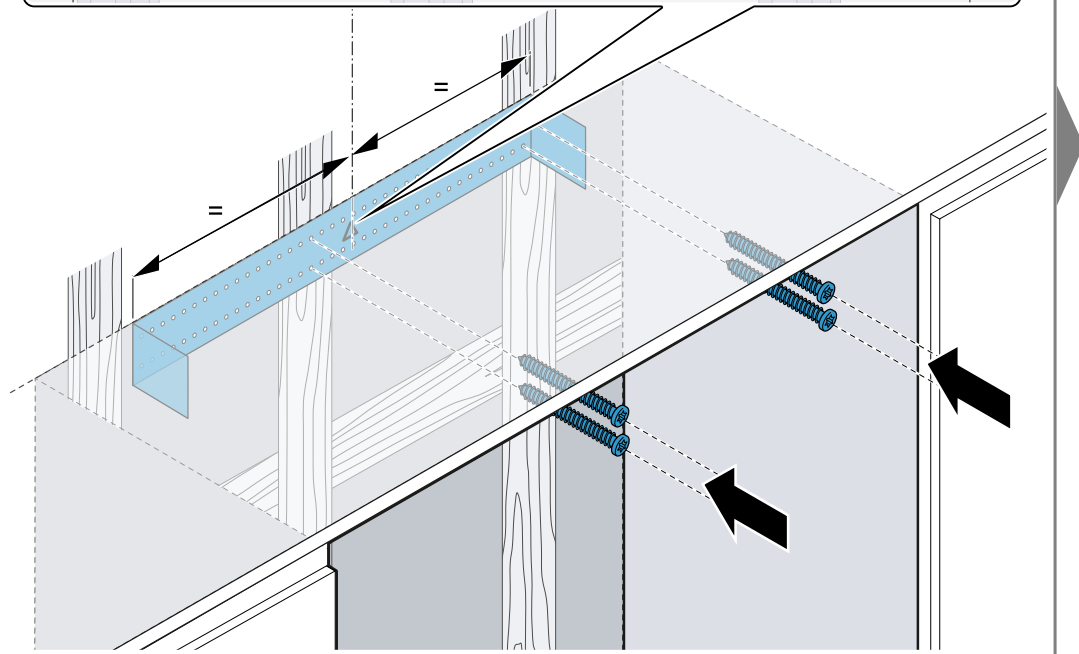
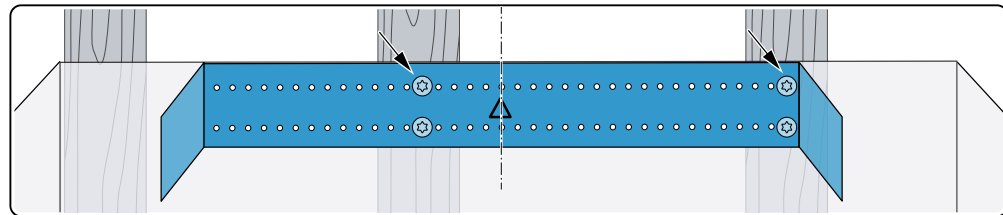
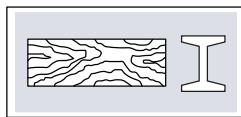
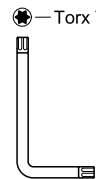



M5x60 T20  
4x

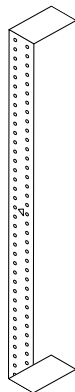
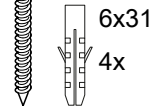

Ø 1/4"  
(6 mm)

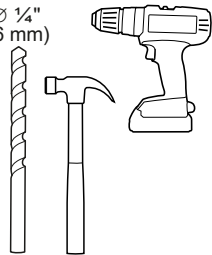

Torx  
T20

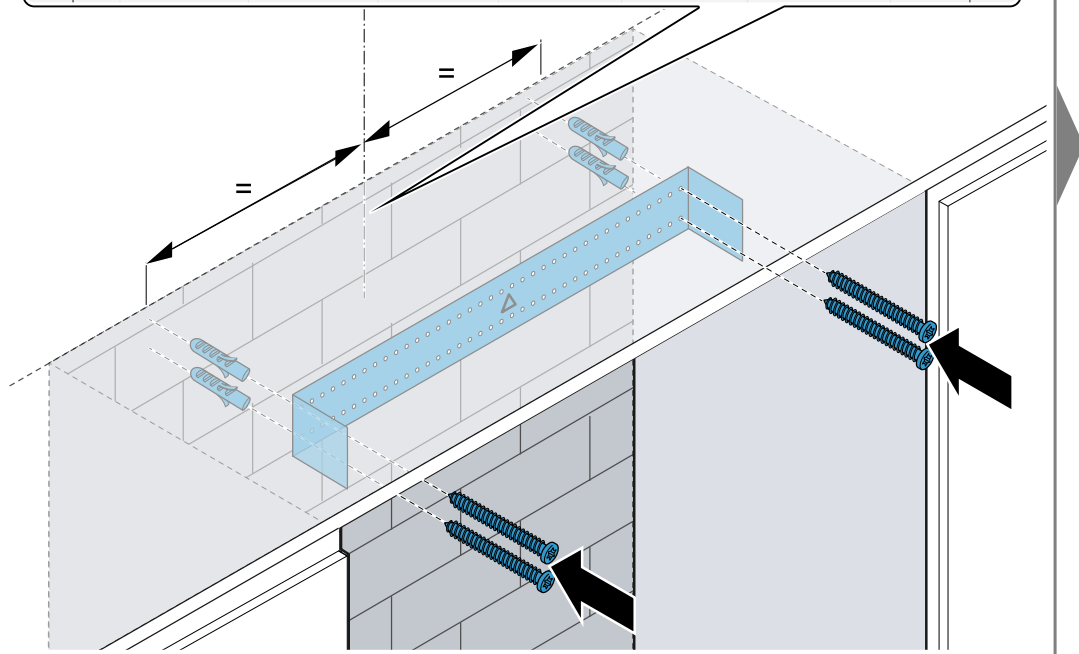
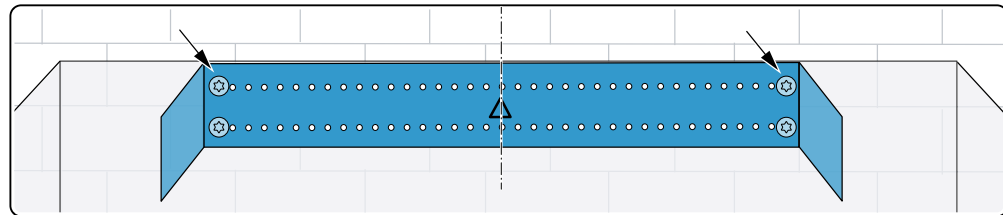
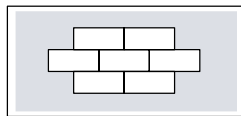
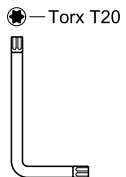

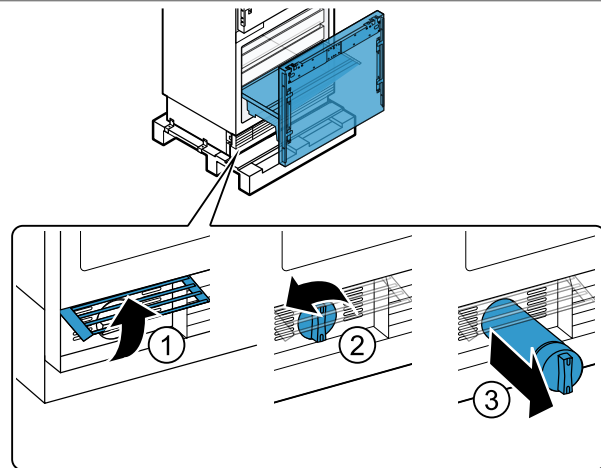
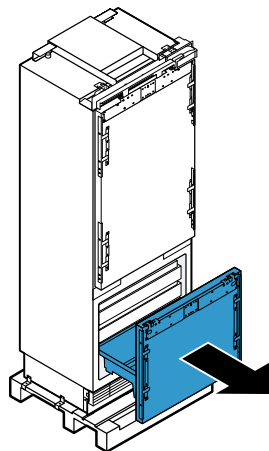
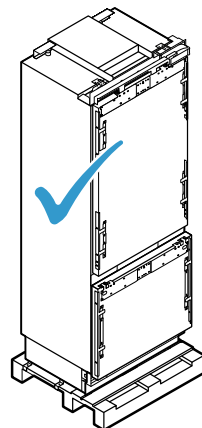
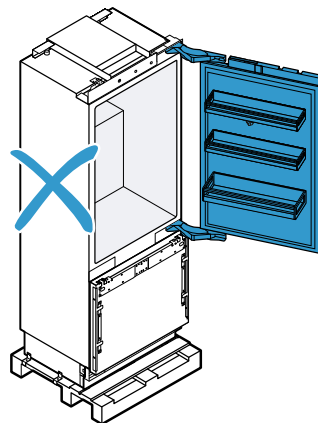

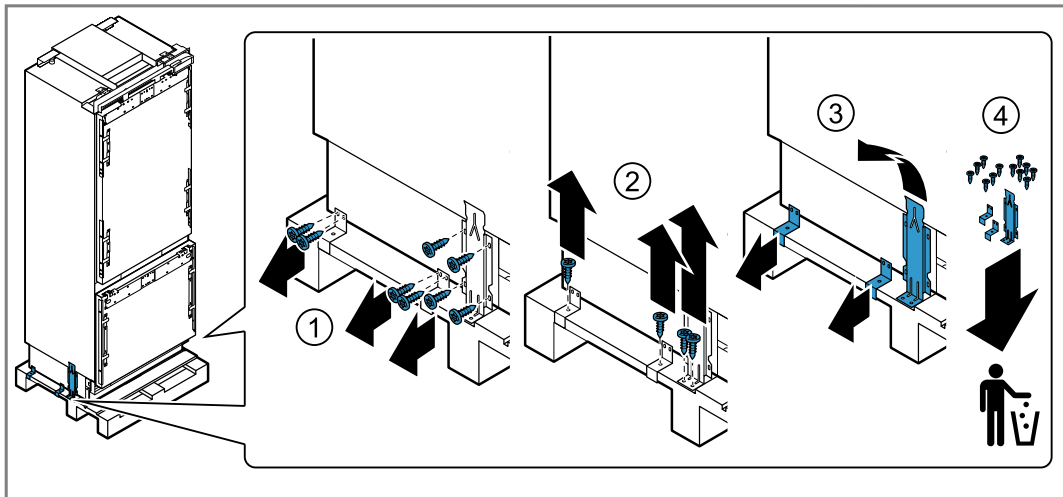
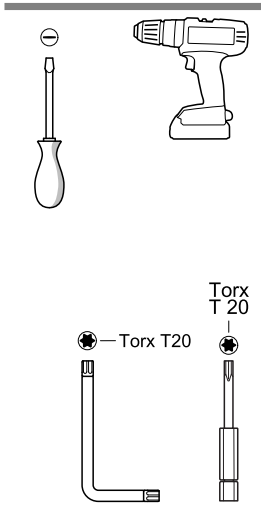
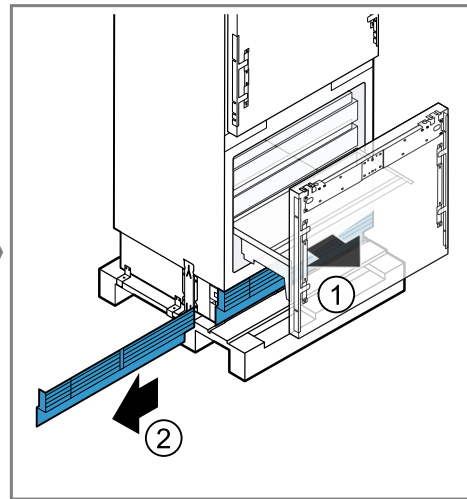
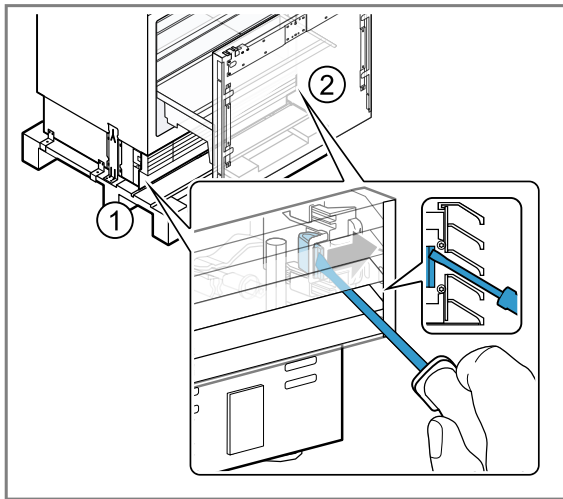

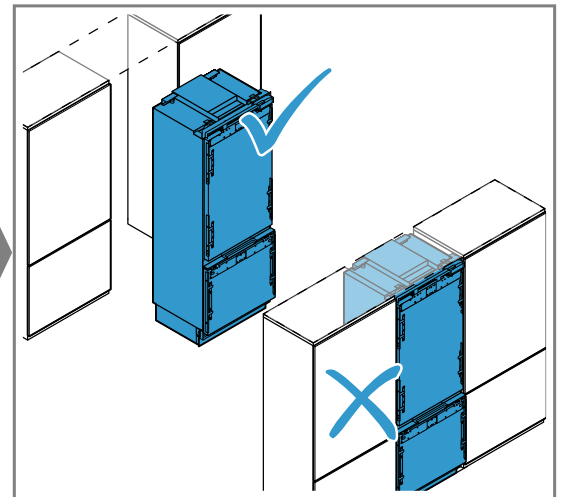
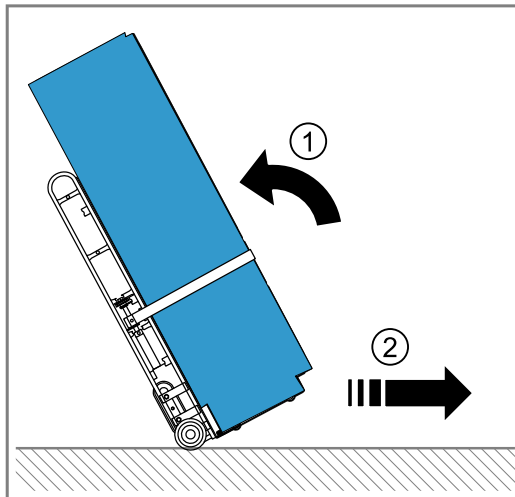
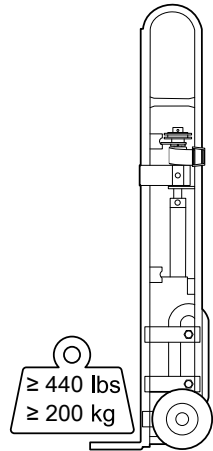
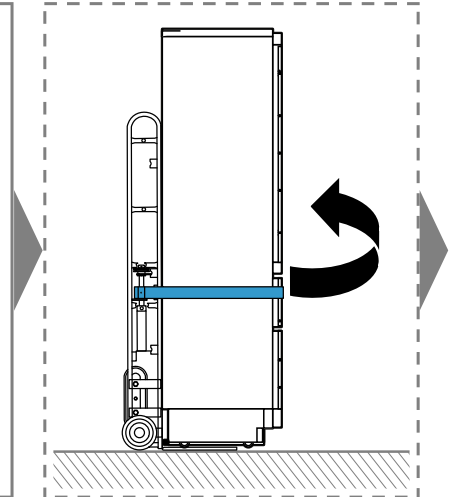
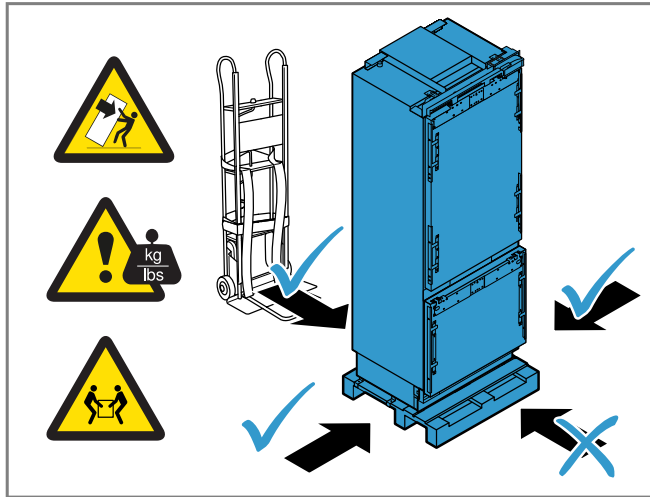

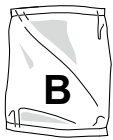

M4.2x6.5 T20

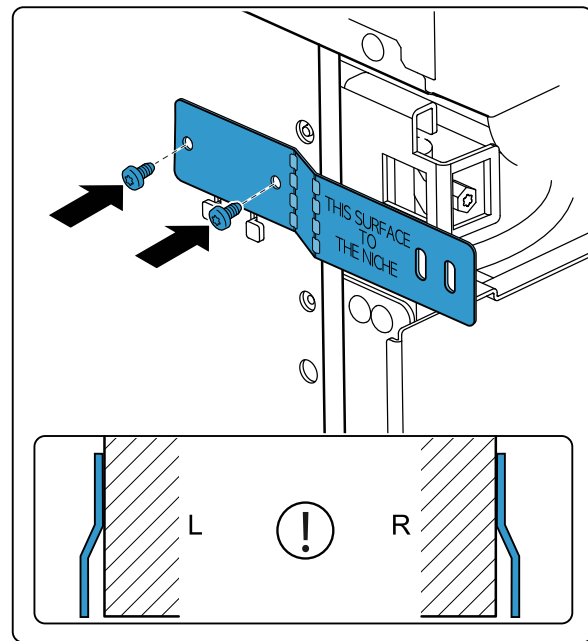
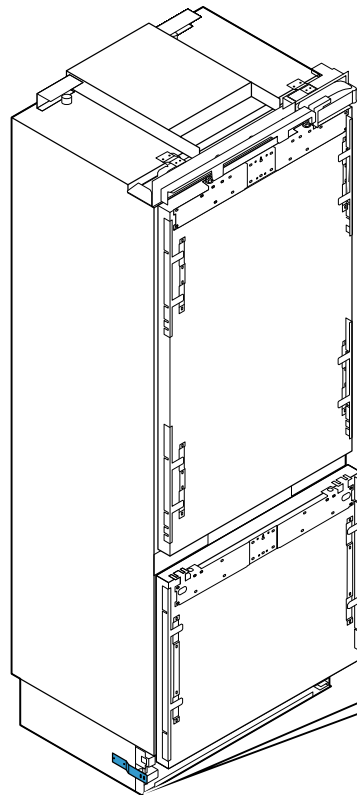
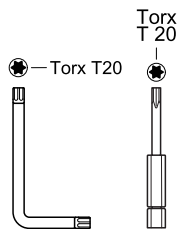
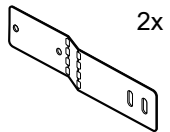

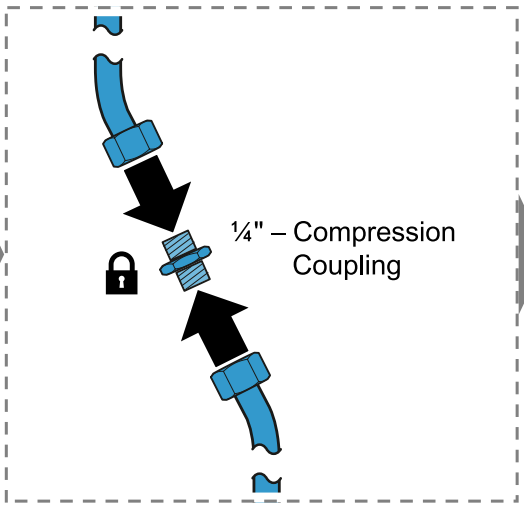
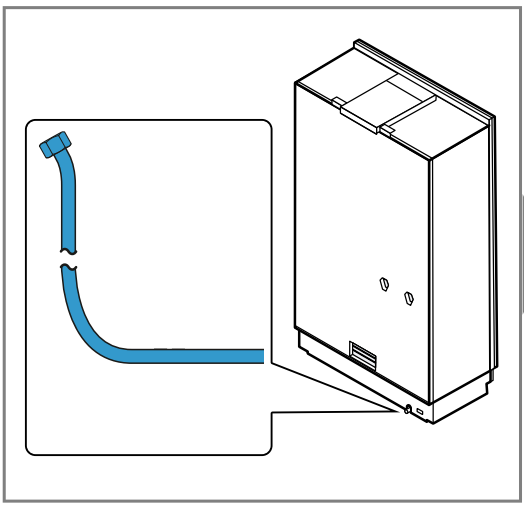

13 mm

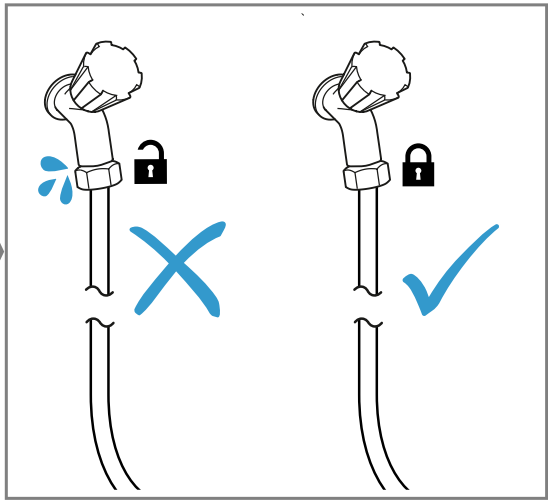
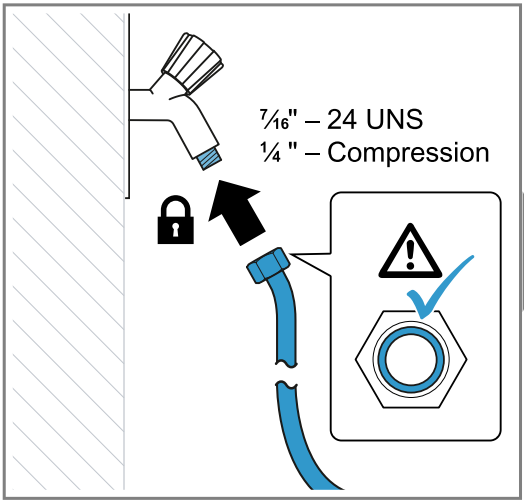
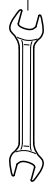

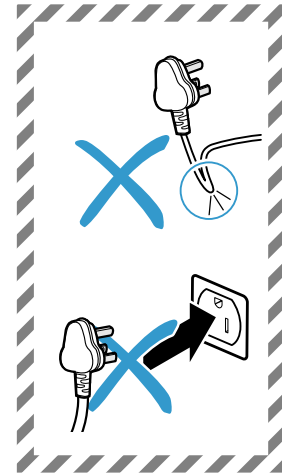
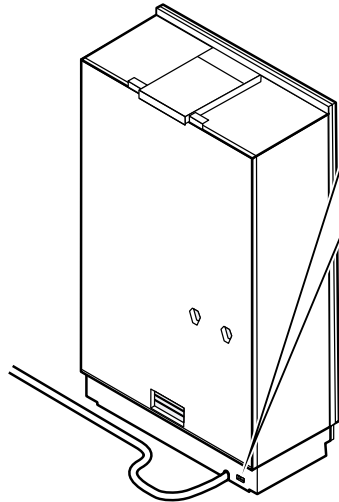
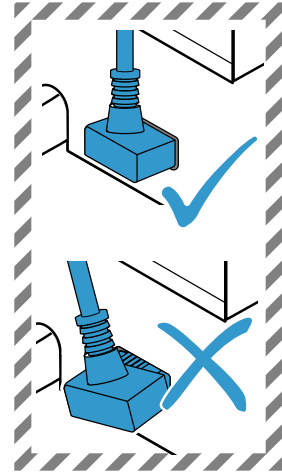
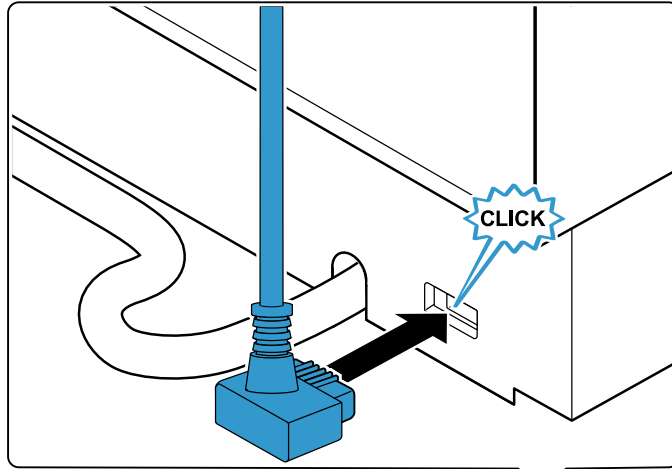

T2

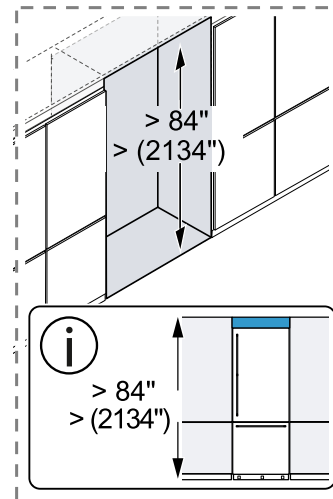
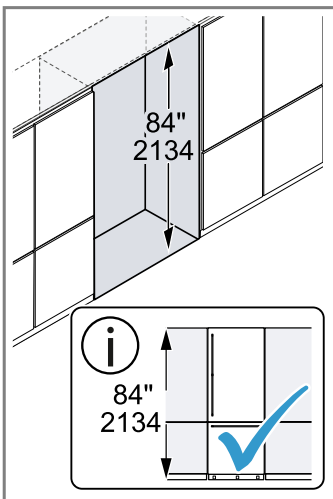
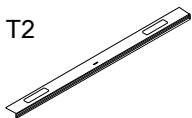

84" – 84<sup>3</sup>/<sub>8</sub>" → A

84<sup>3</sup>/<sub>8</sub>" – 84<sup>1</sup>/<sub>2</sub>" → B

84<sup>1</sup>/<sub>2</sub>" – 84<sup>5</sup>/<sub>8</sub>" → C

? X = .....

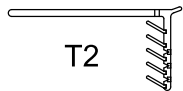
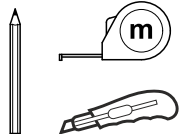

T2

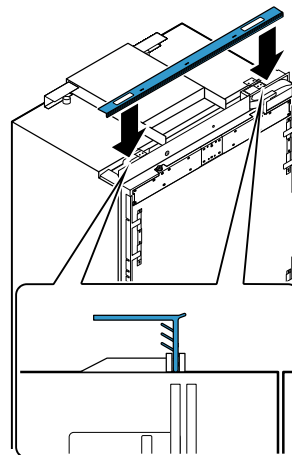
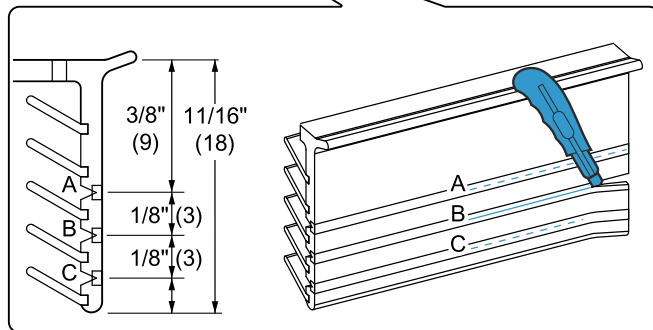

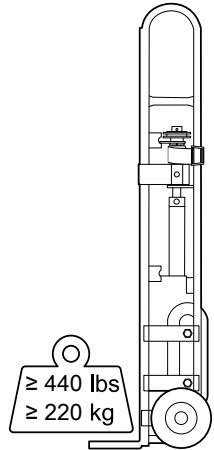
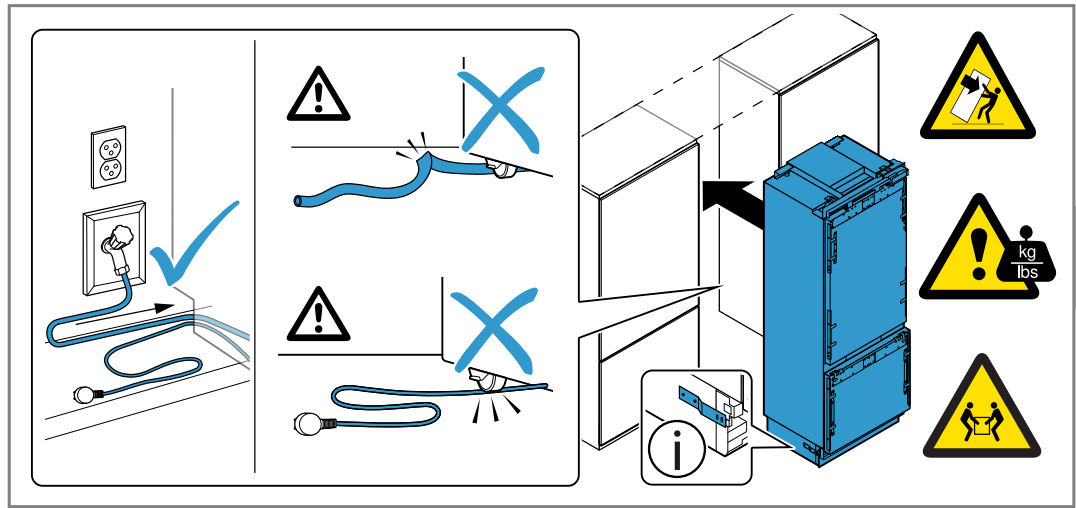

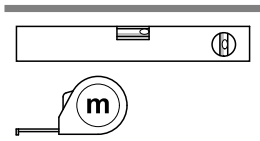
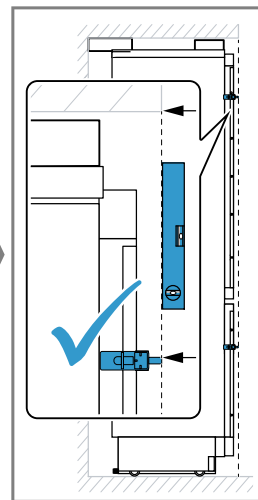
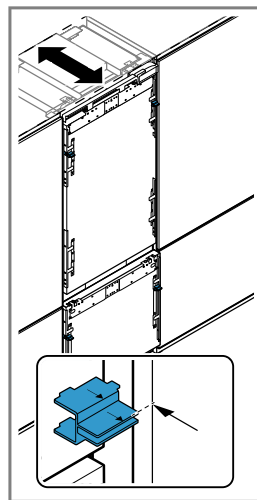
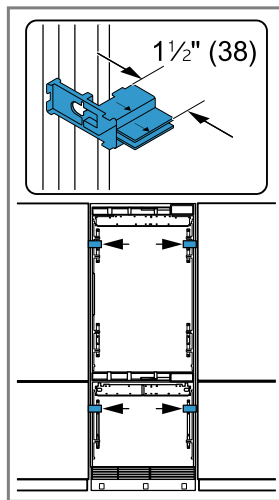
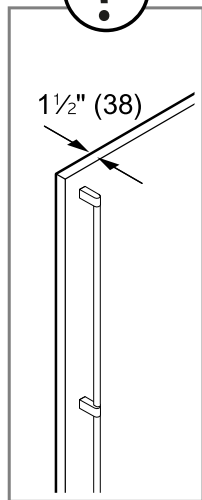
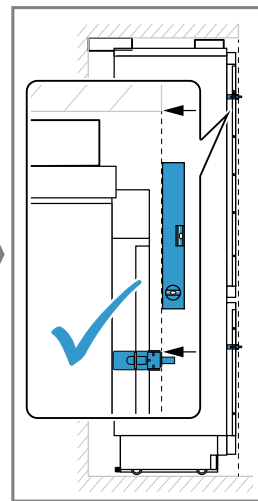
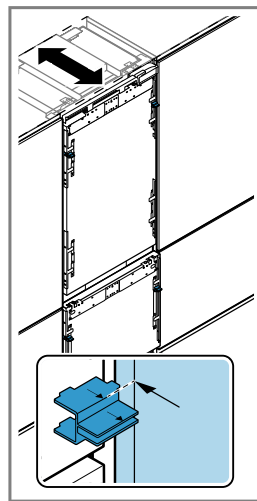
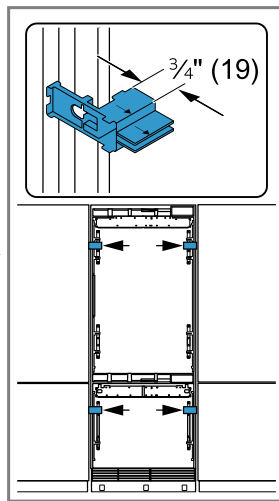
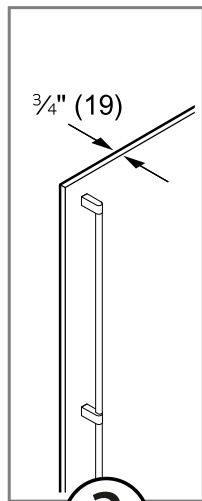

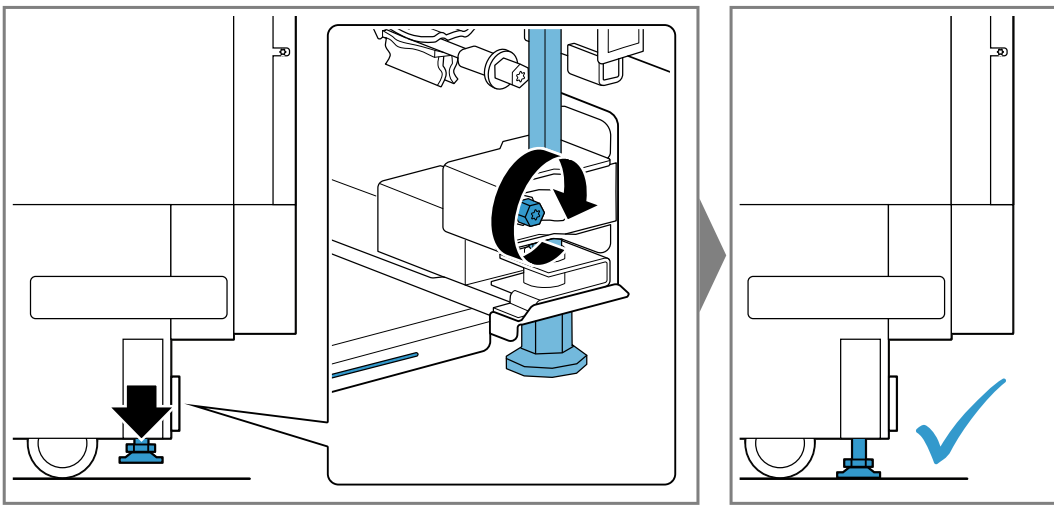
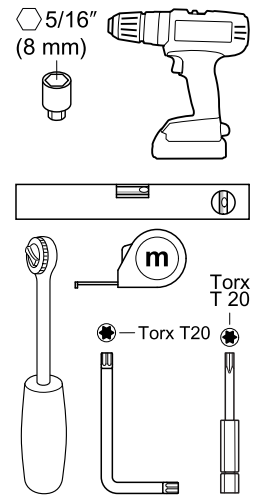
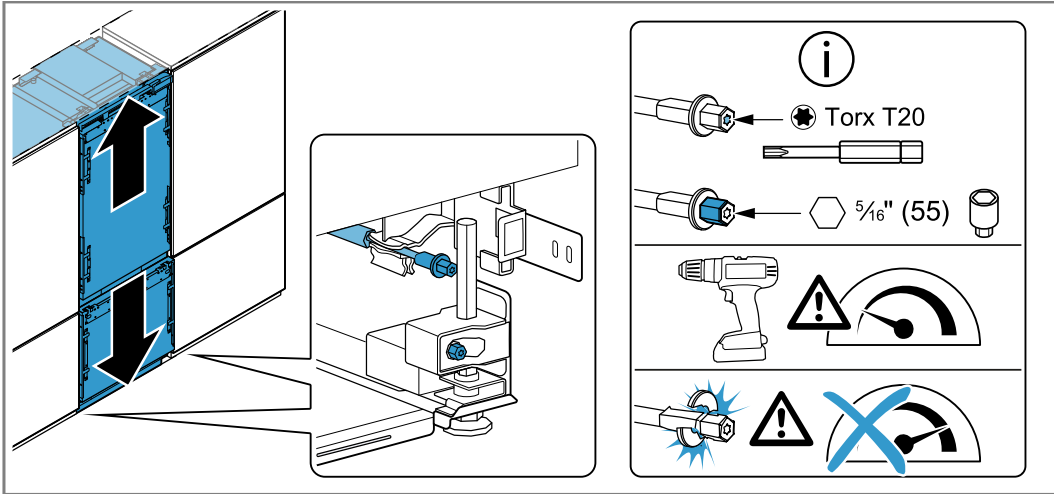



C

2x

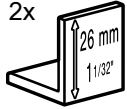

5/16" (8 mm)

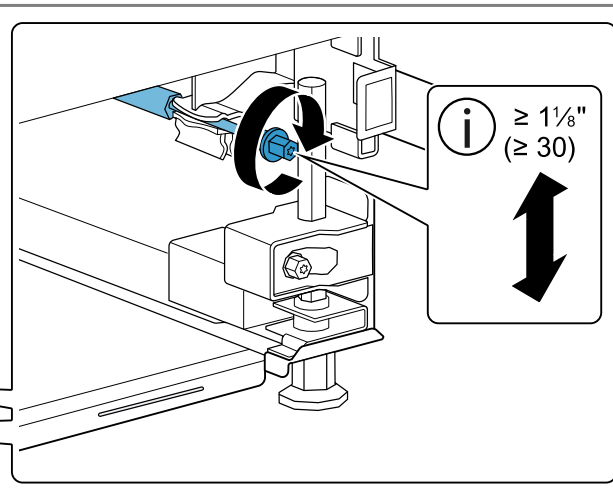
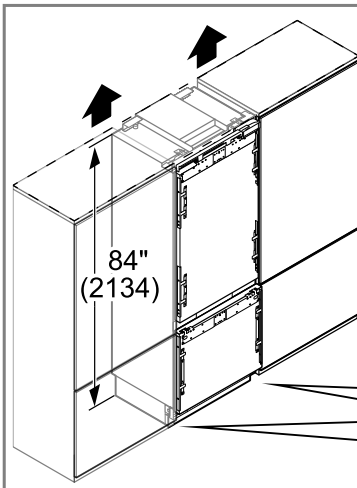
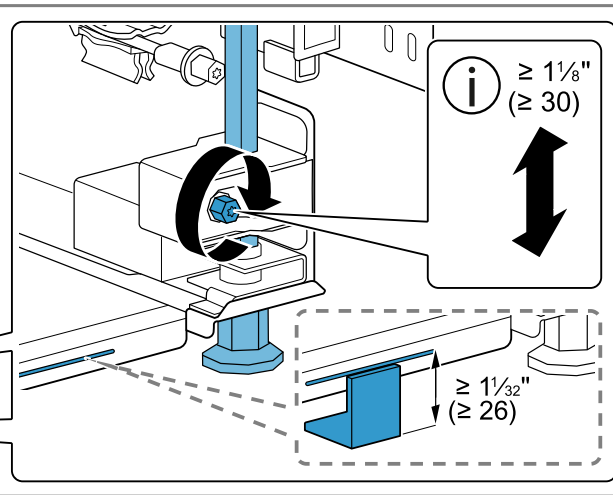
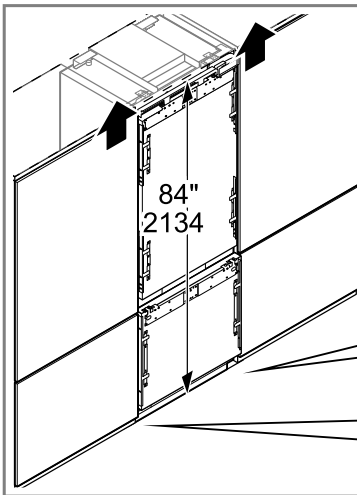
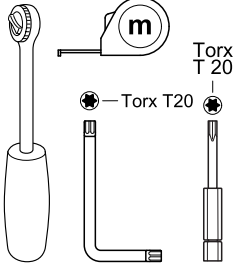
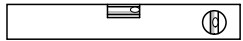

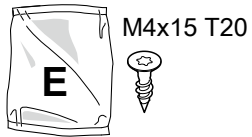

T2

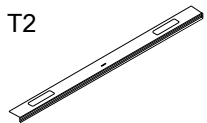

90°

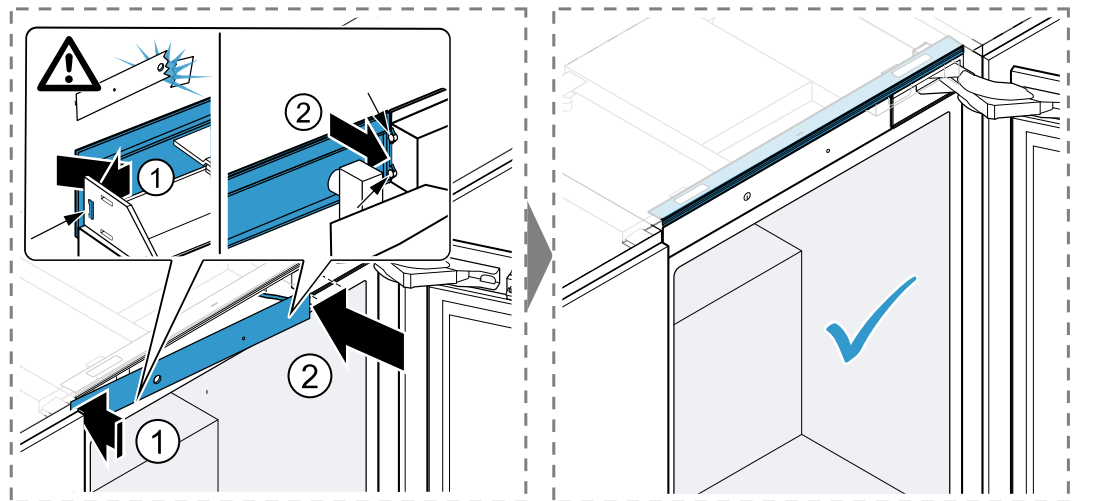
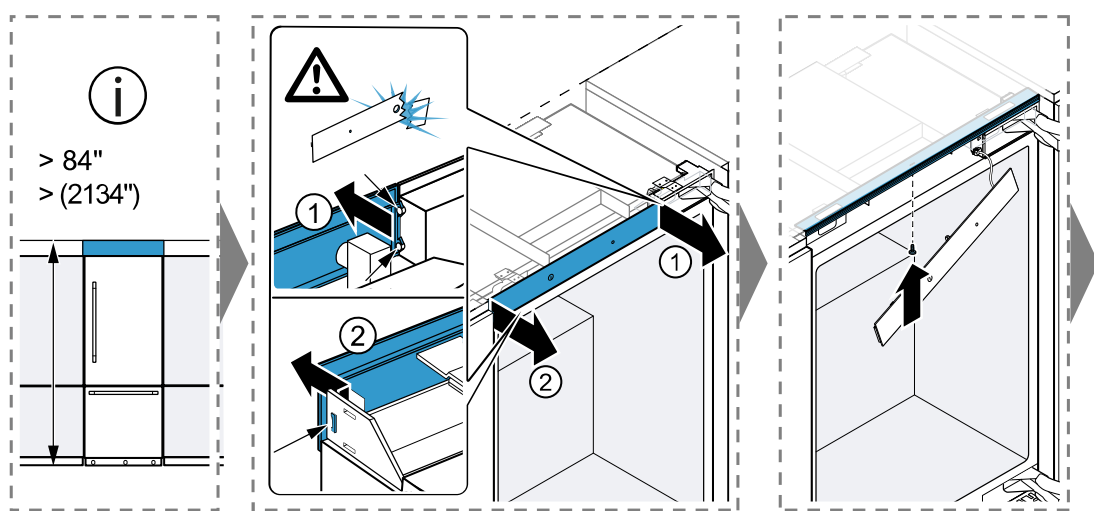
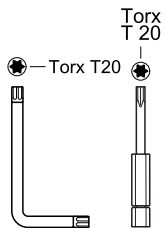

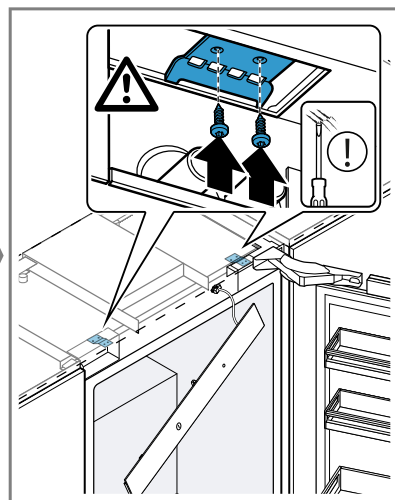
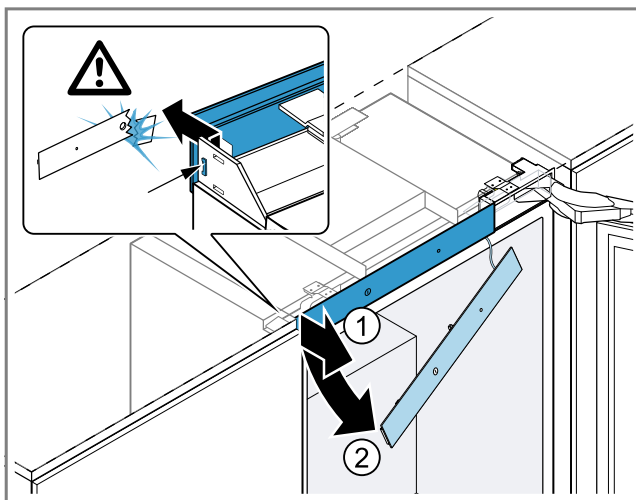
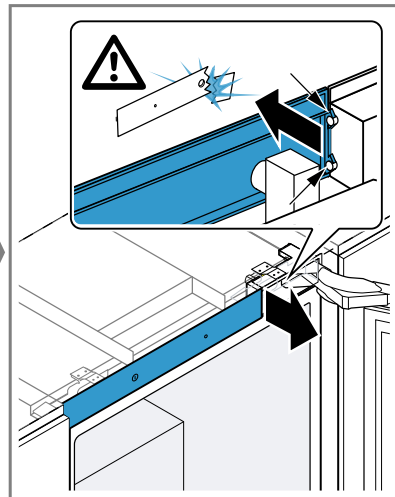
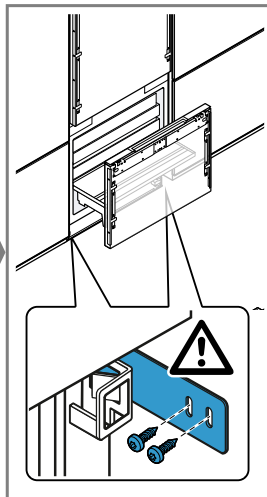
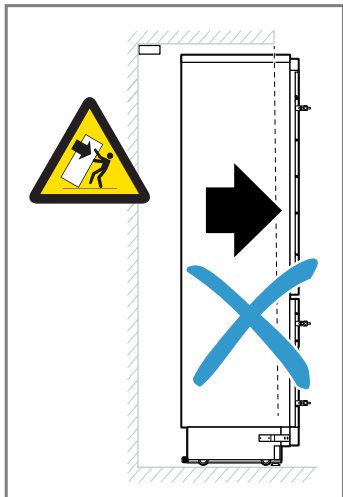
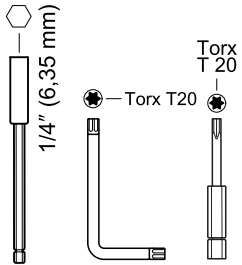
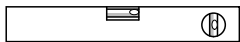
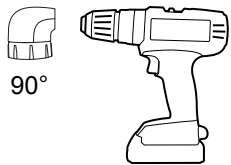
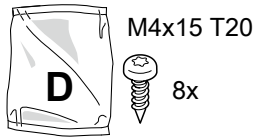

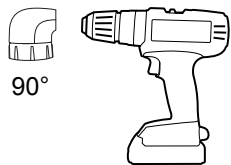
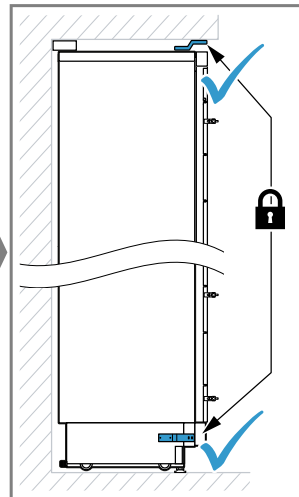
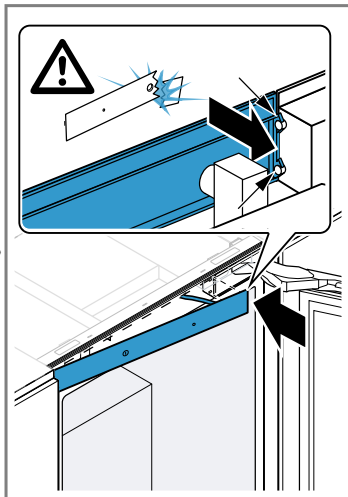
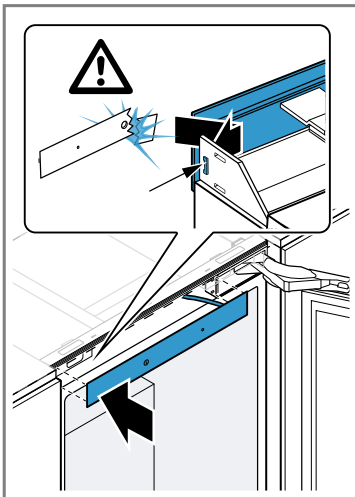

90°

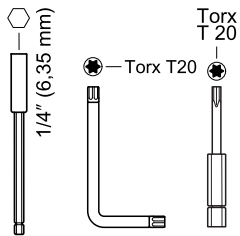

Torx  
T 20

Torx T20

1/4" (6.35 mm)

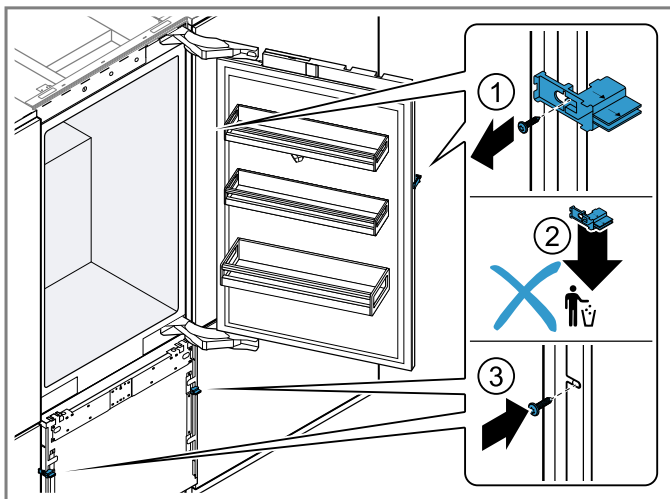
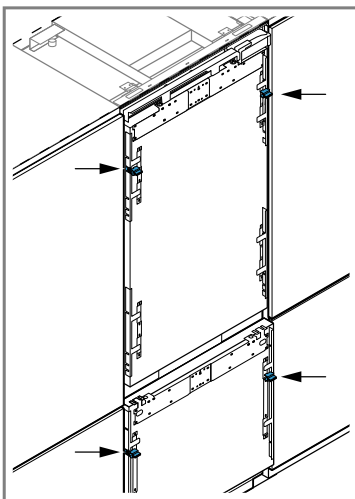

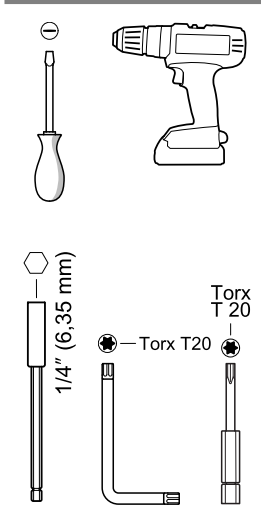
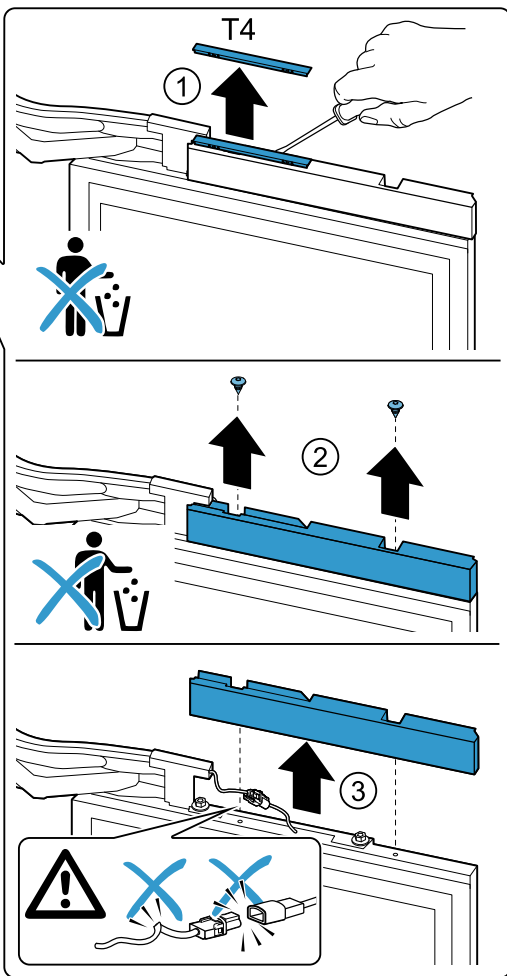
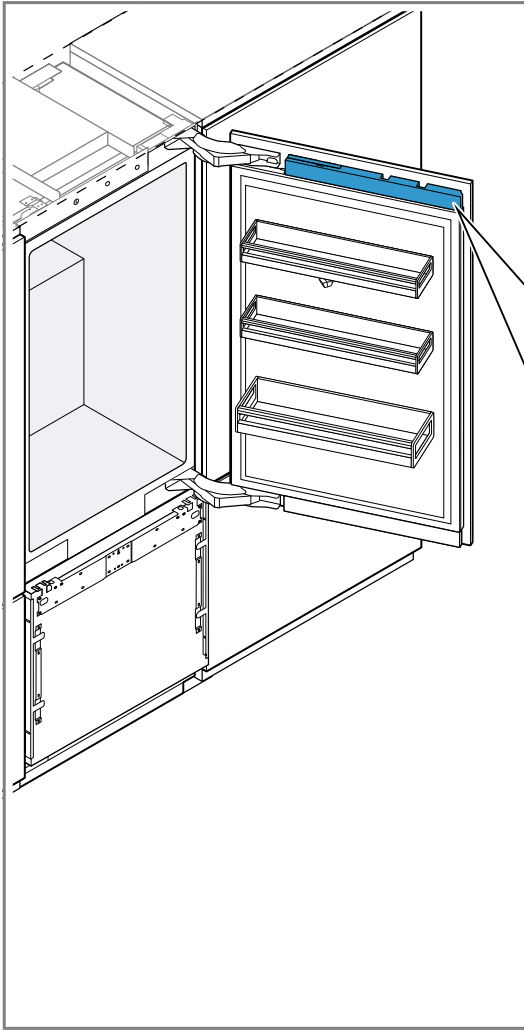

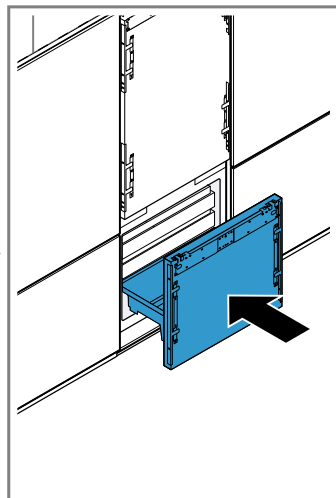
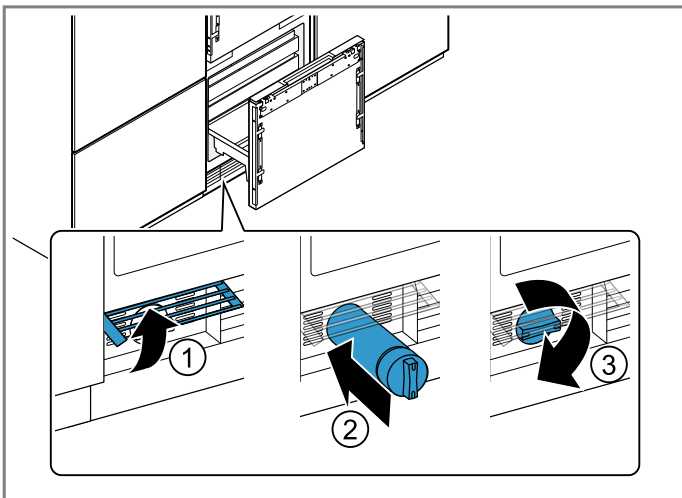
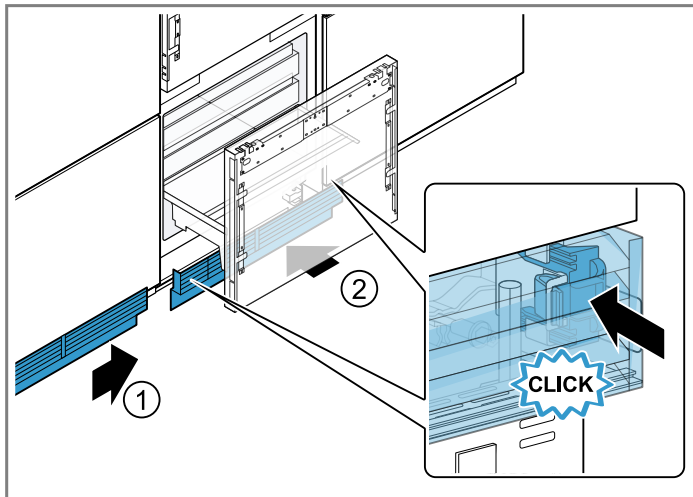
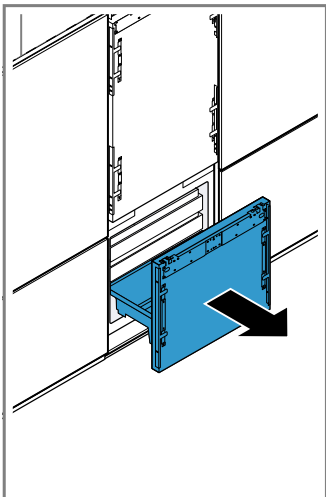

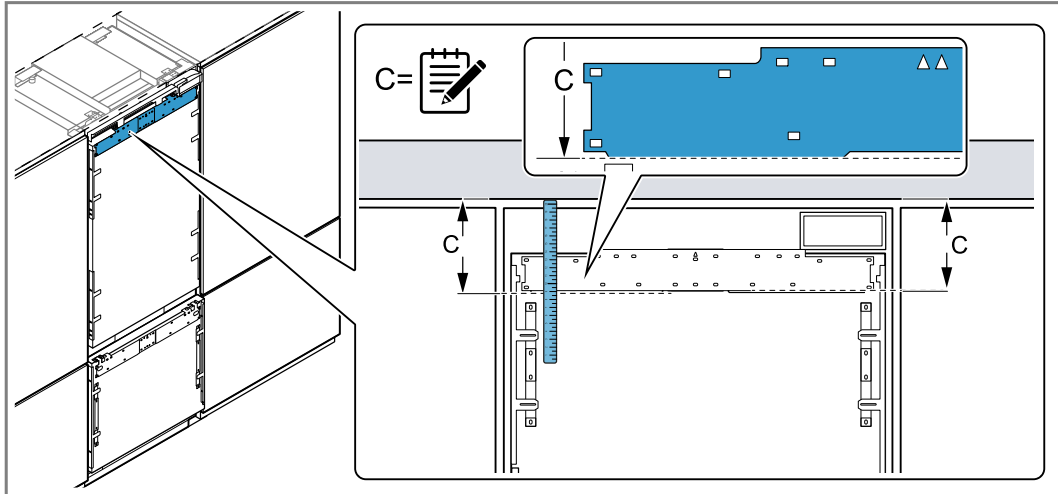

13 mm

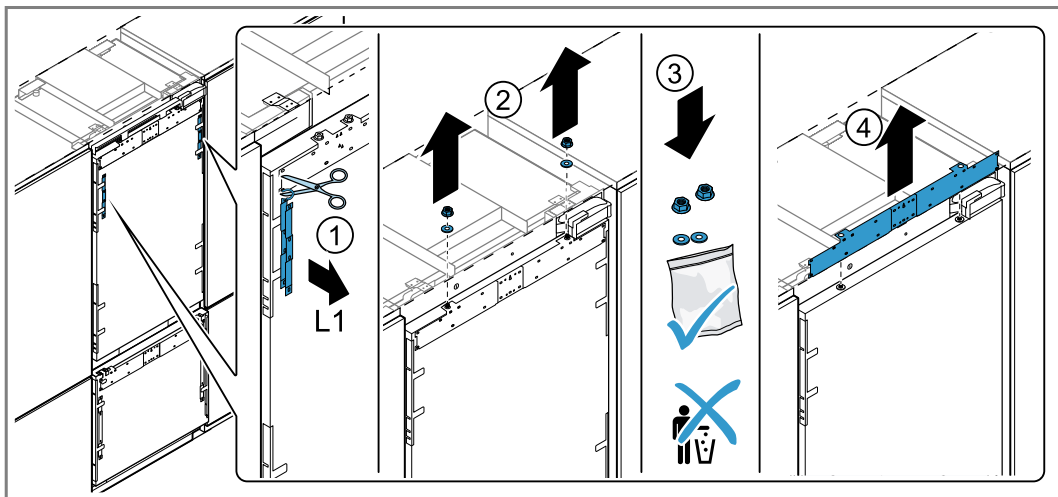
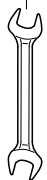

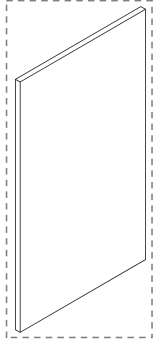
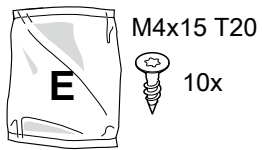

$\varnothing \frac{1}{8}''$   
(2 mm)

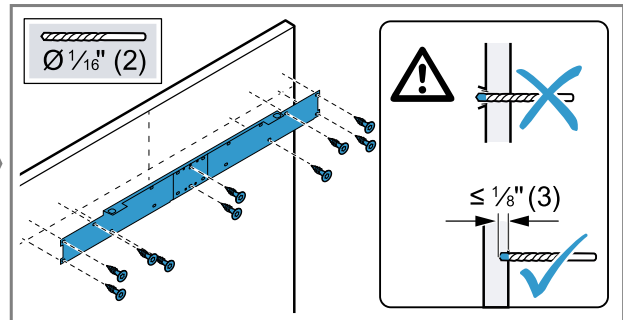
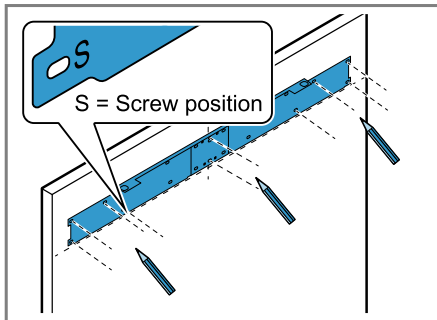
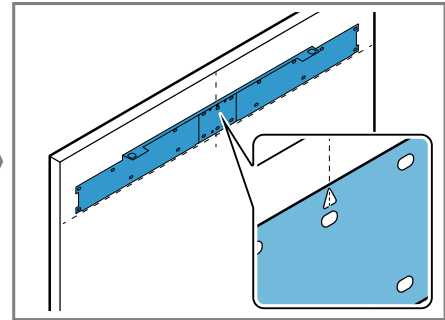
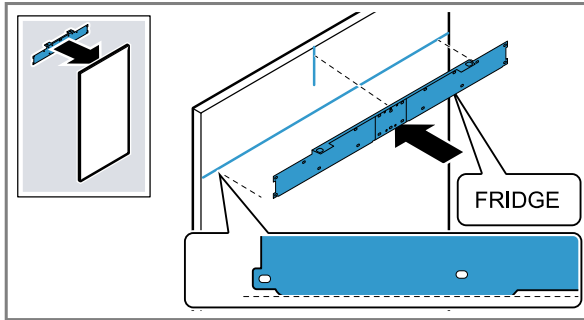
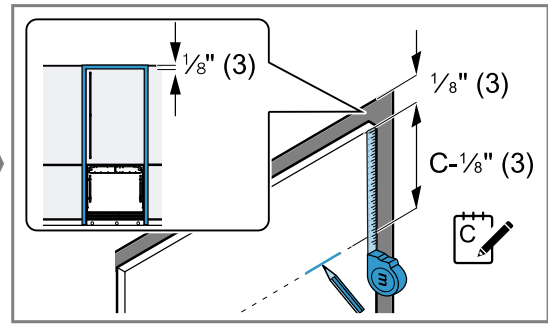
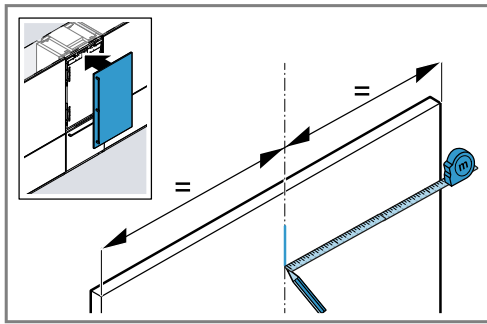
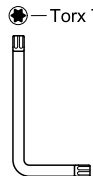

M4x15 T20  
E 16x

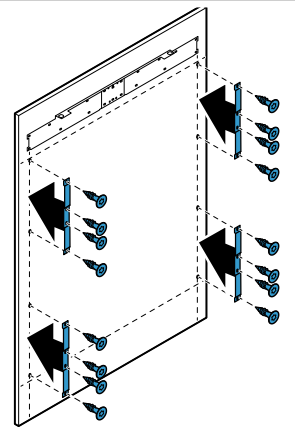
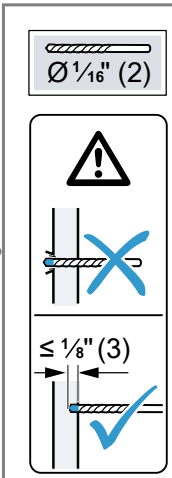
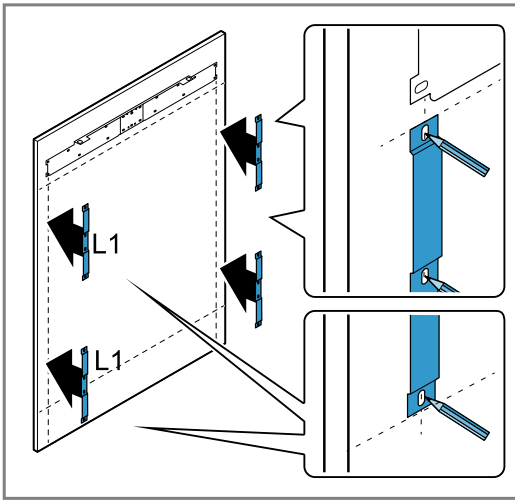
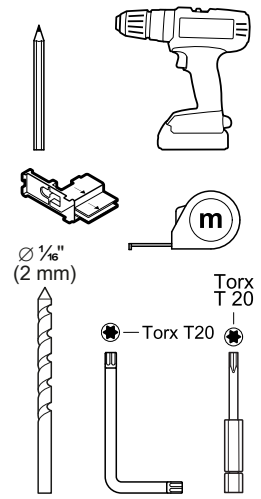
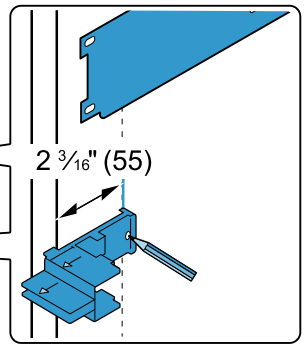
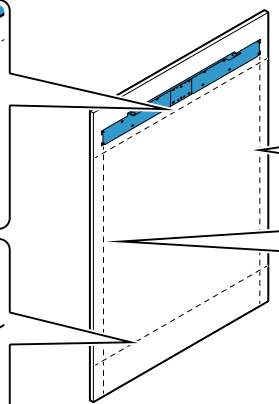
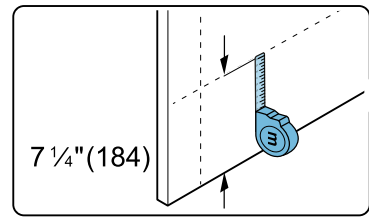
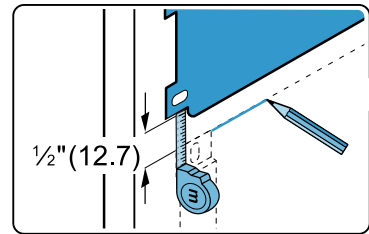
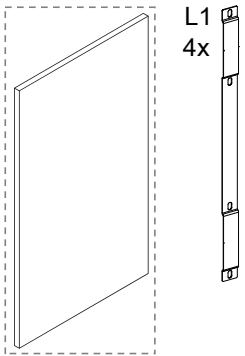

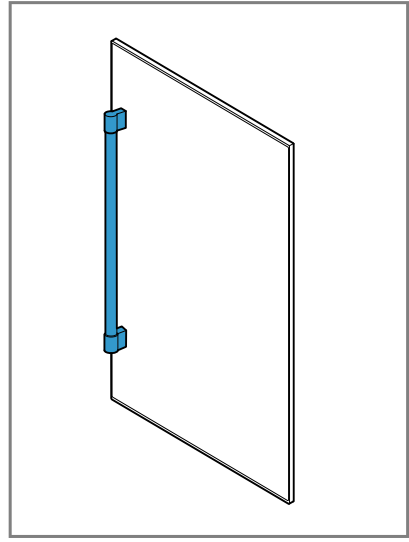
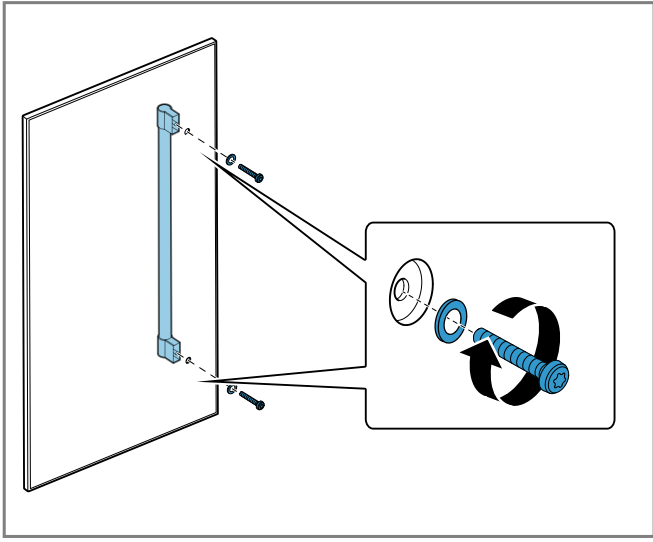
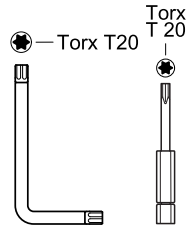
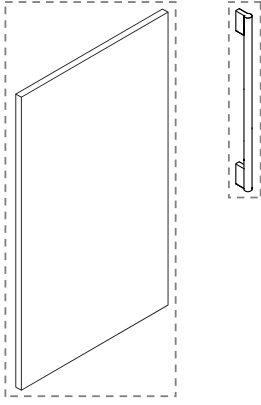

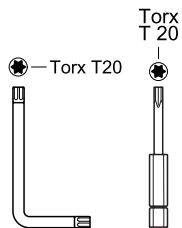
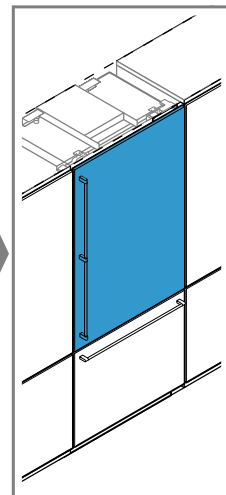
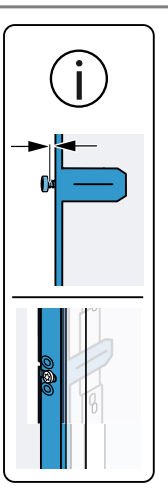
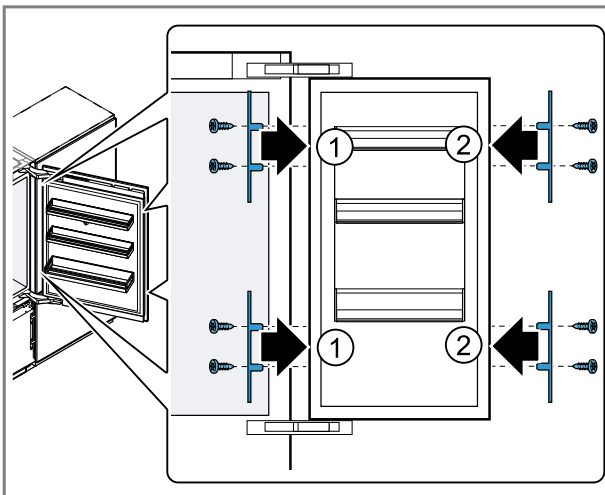
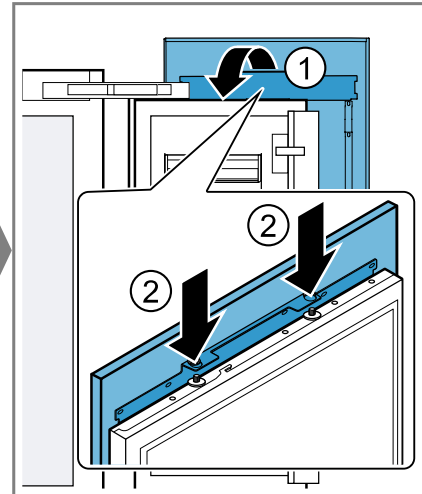
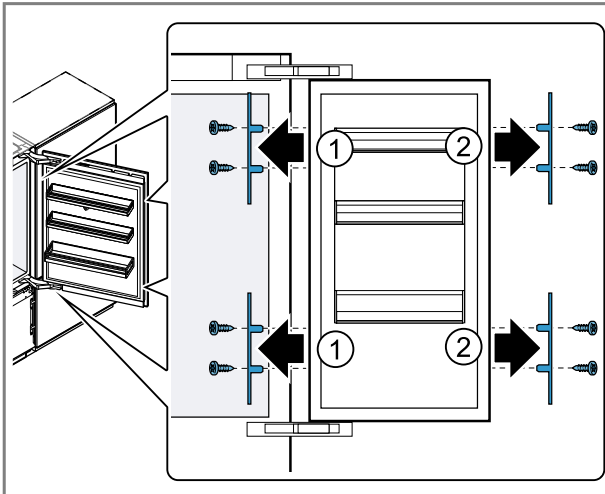
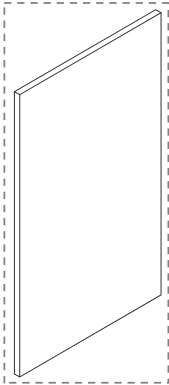



2x

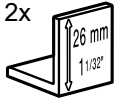

13 mm

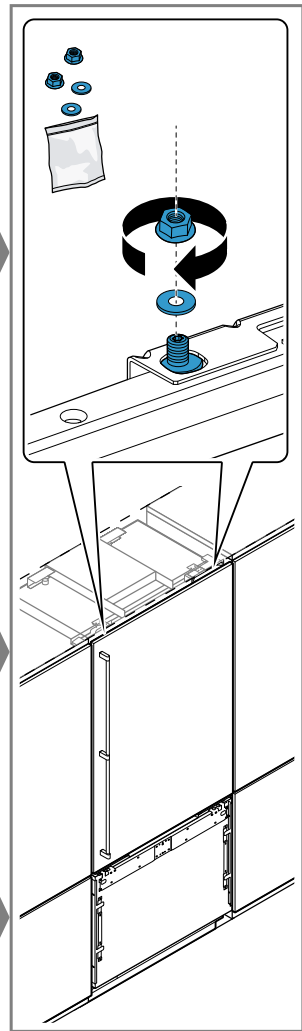
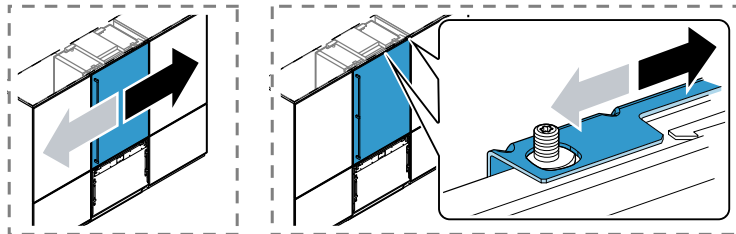
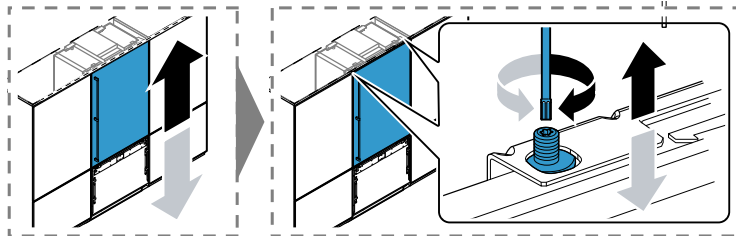
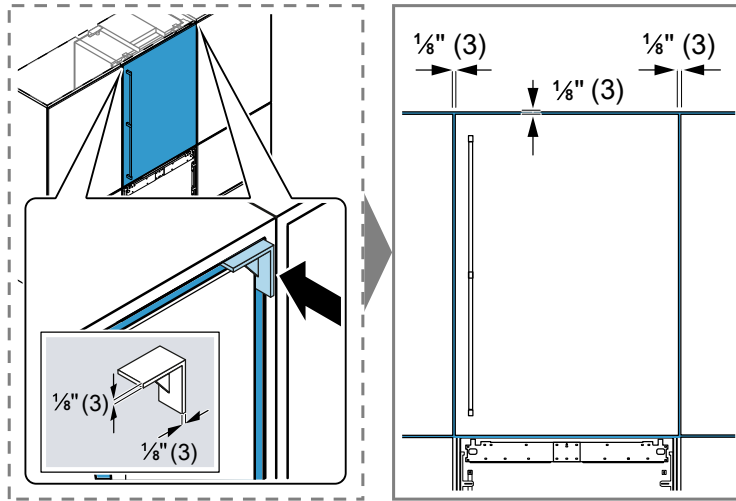
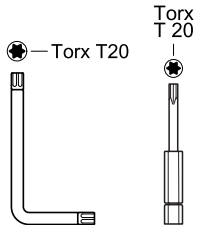
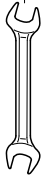

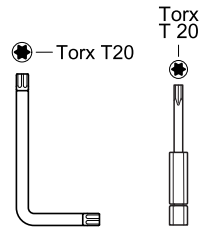
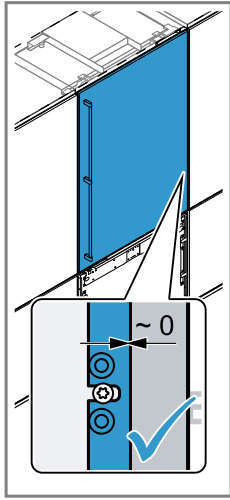
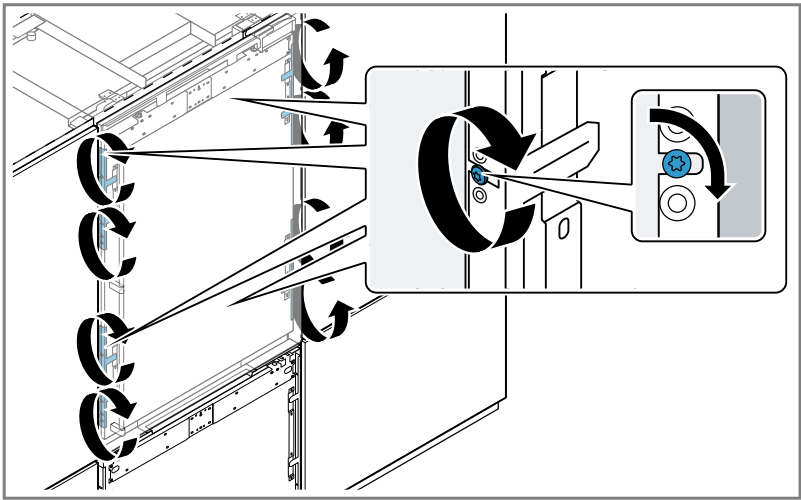
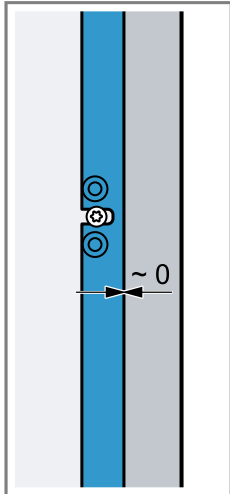
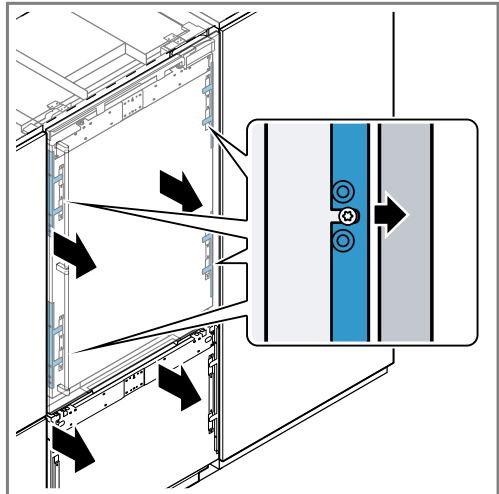
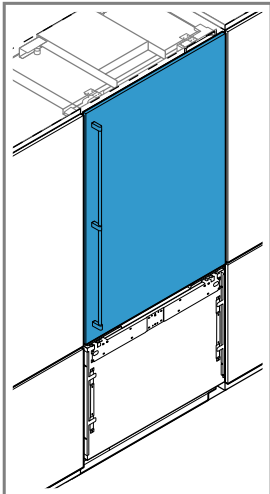

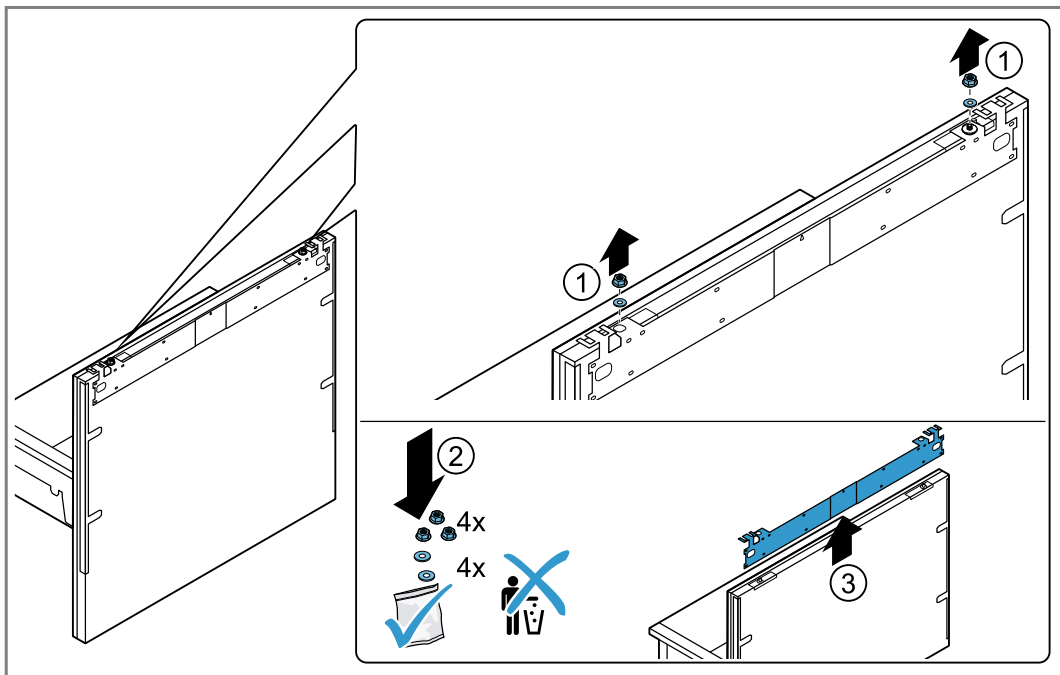
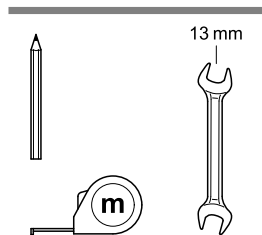
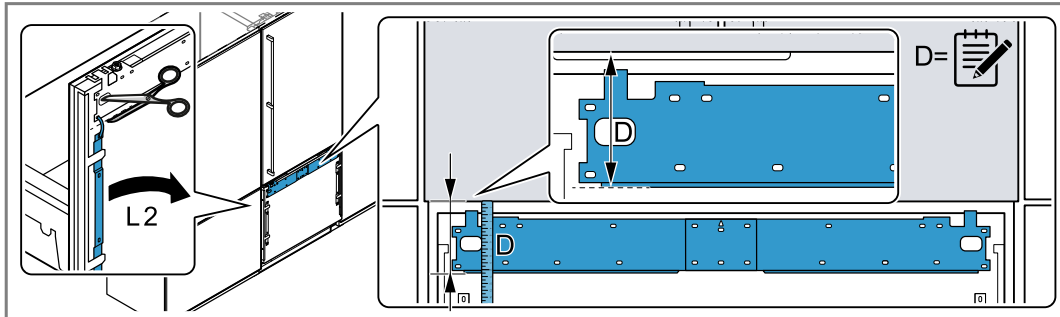

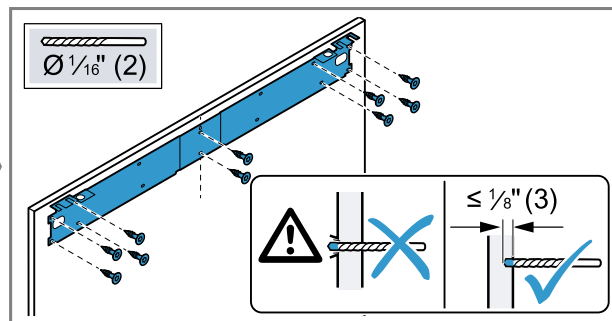
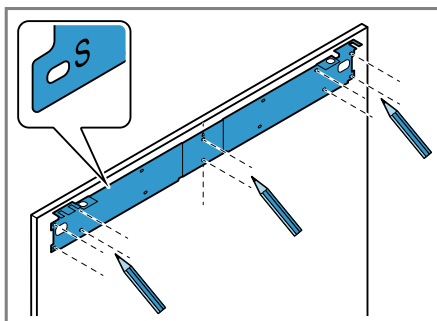
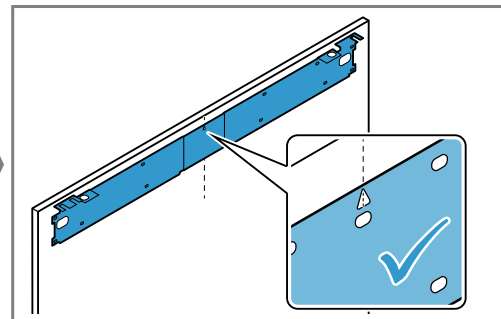
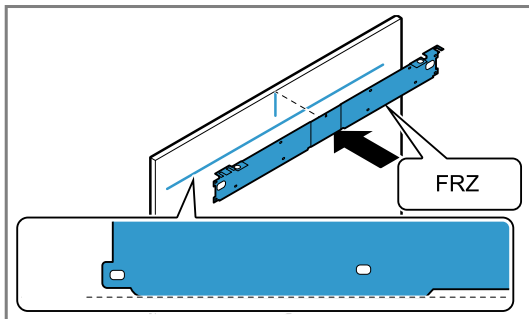
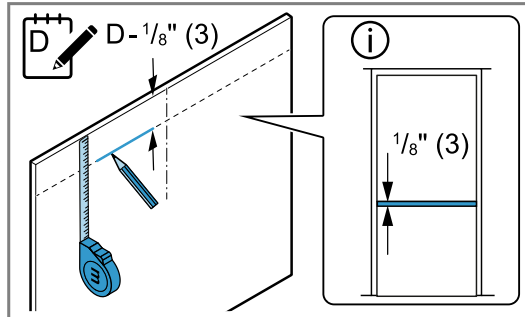
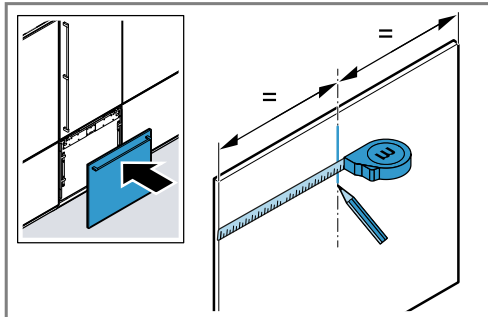
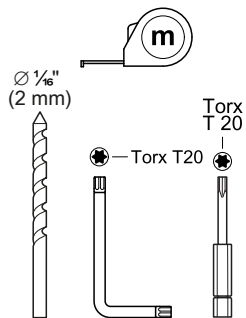
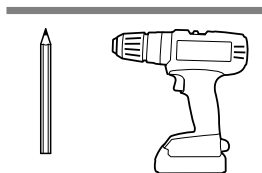
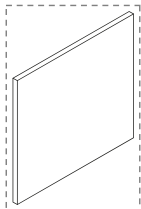
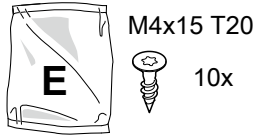

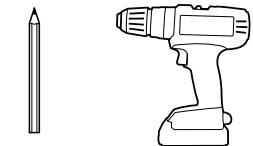
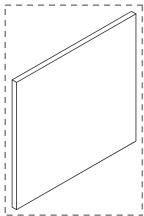

$\varnothing \frac{1}{16}''$   
(2 mm)

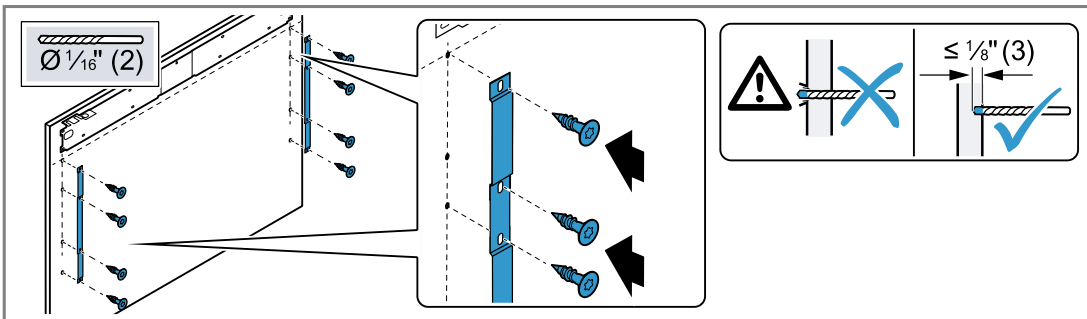
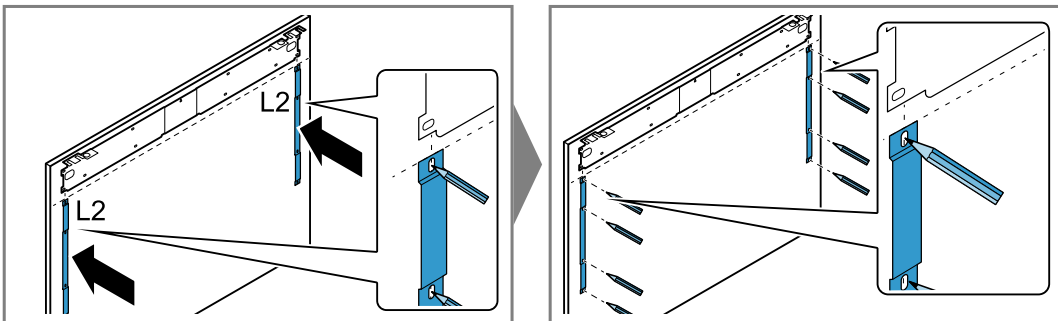
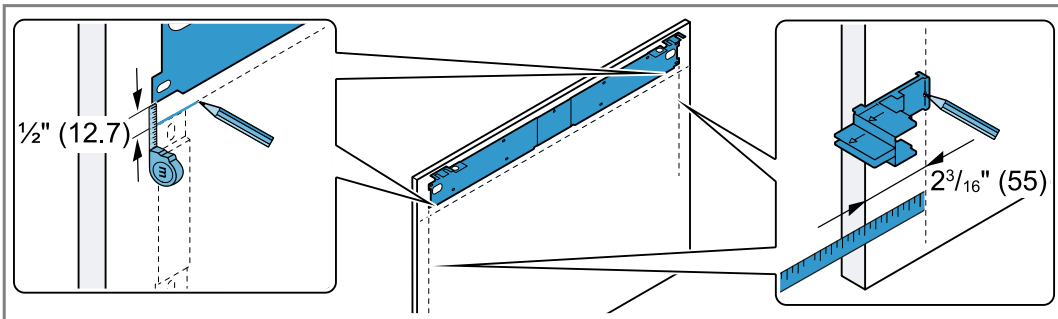
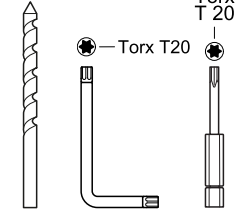

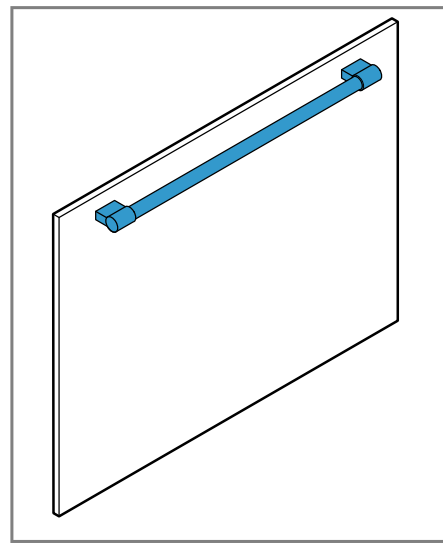
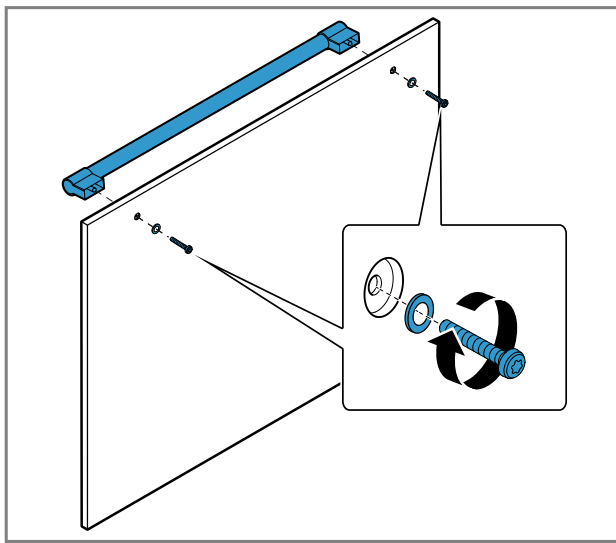
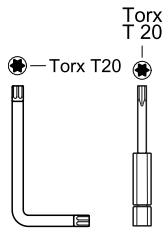
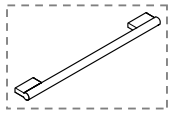
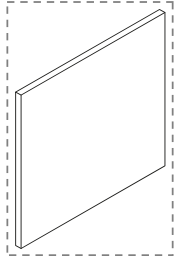

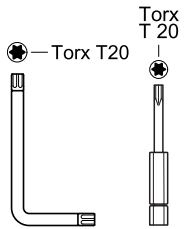
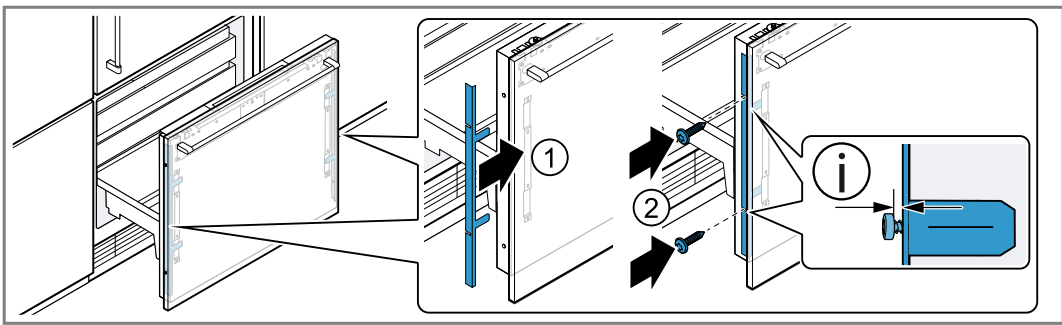
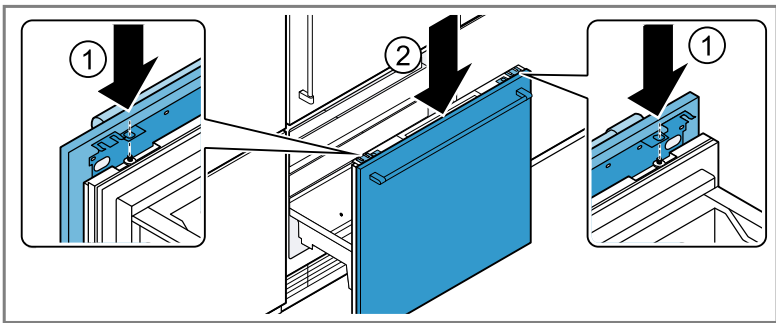
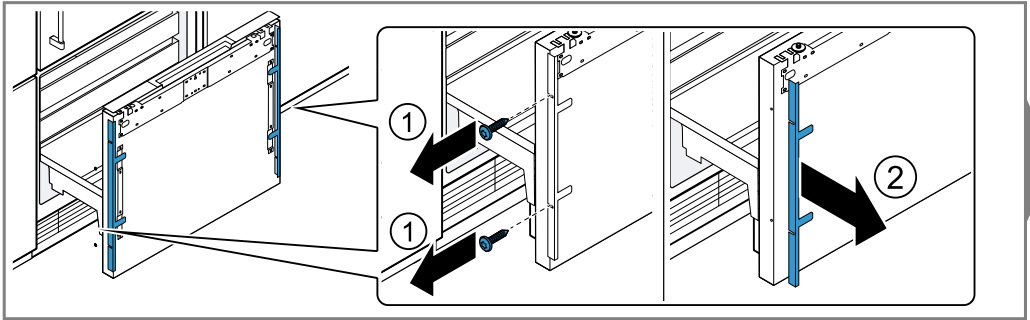
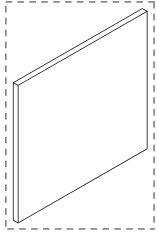



2x

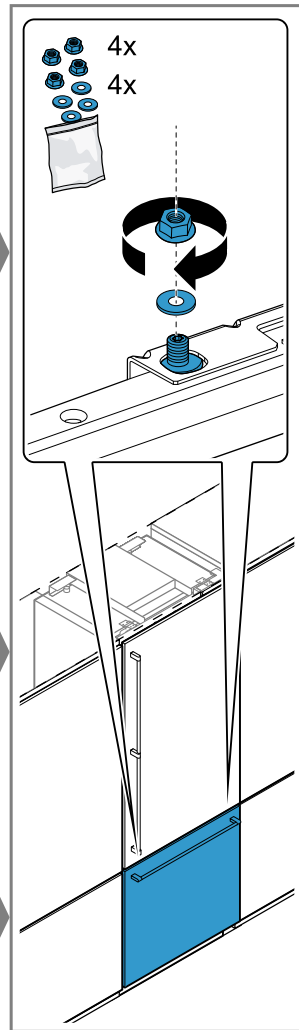
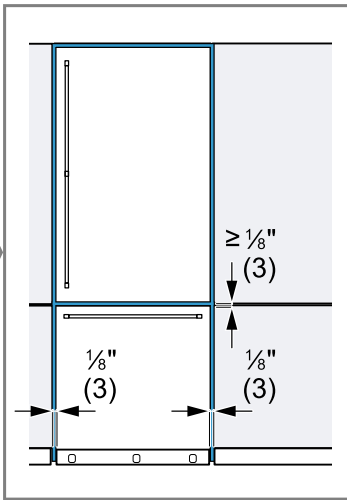
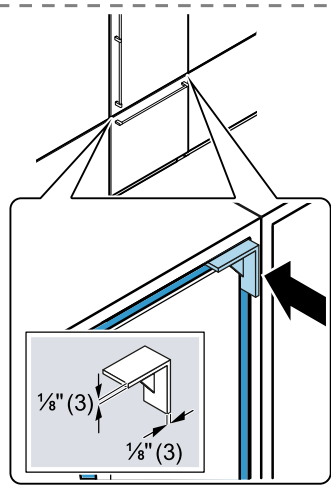
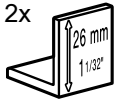

13 mm

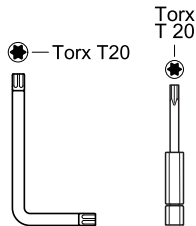
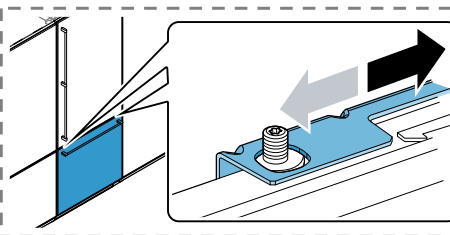
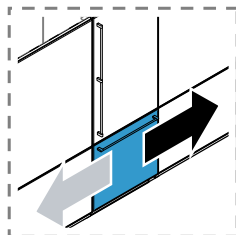
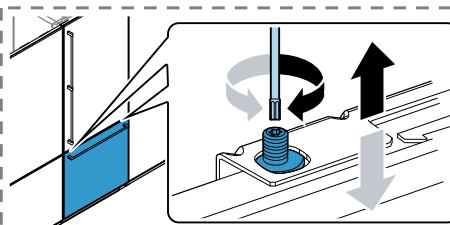
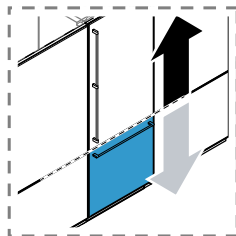
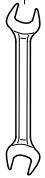

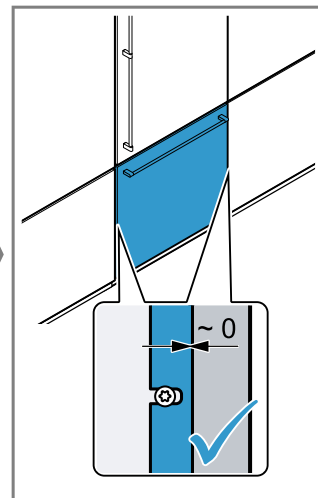
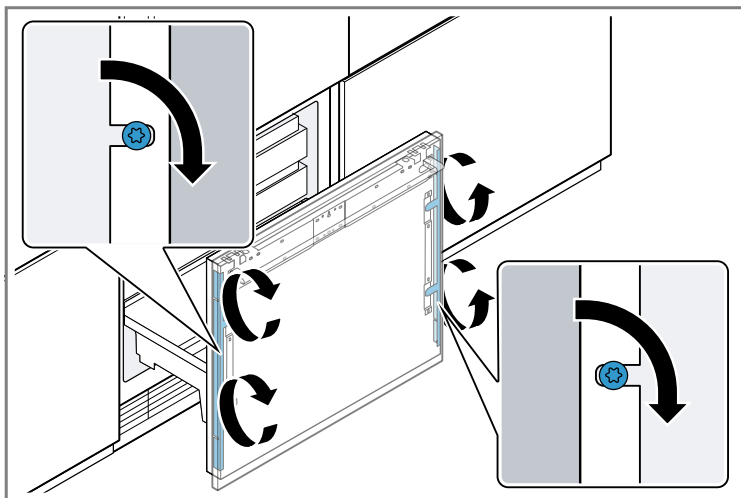
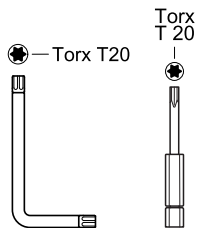
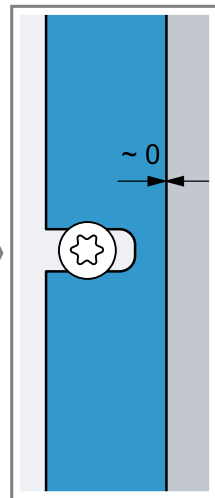
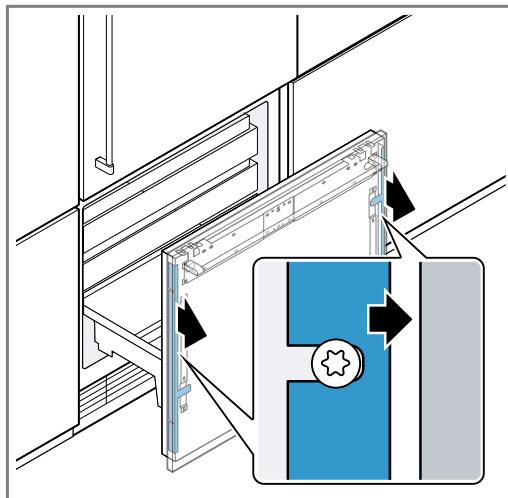
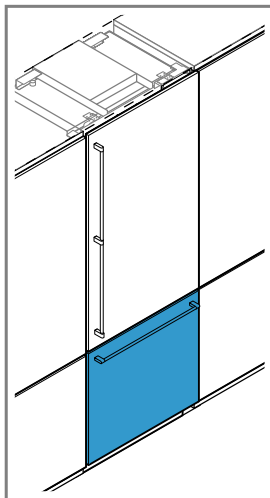

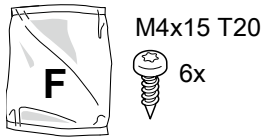

Ø 1/16"  
(2 mm)

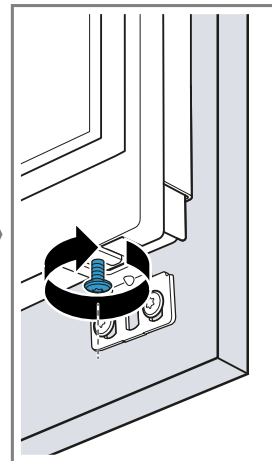
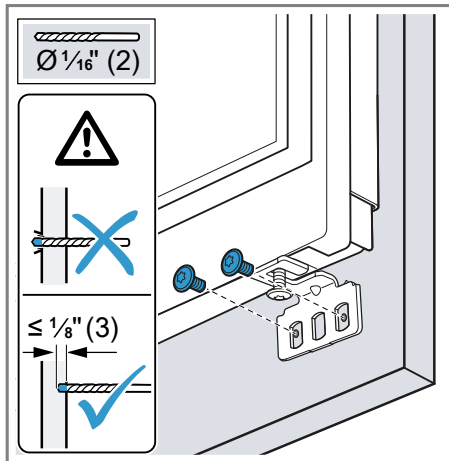
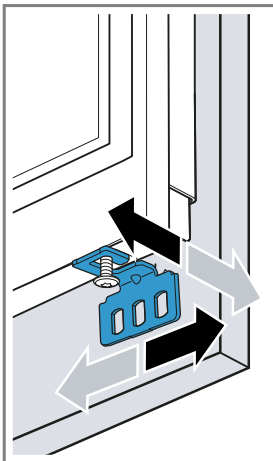
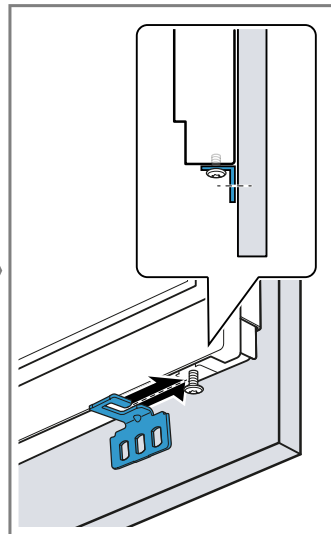
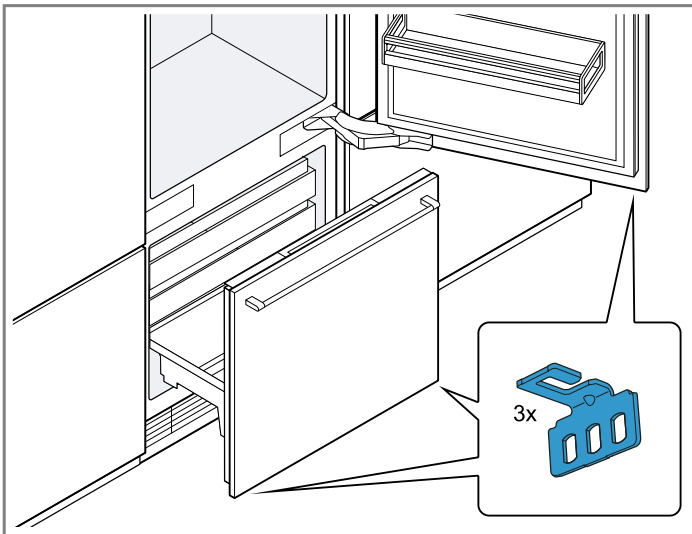
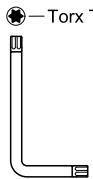
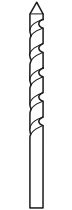



2x

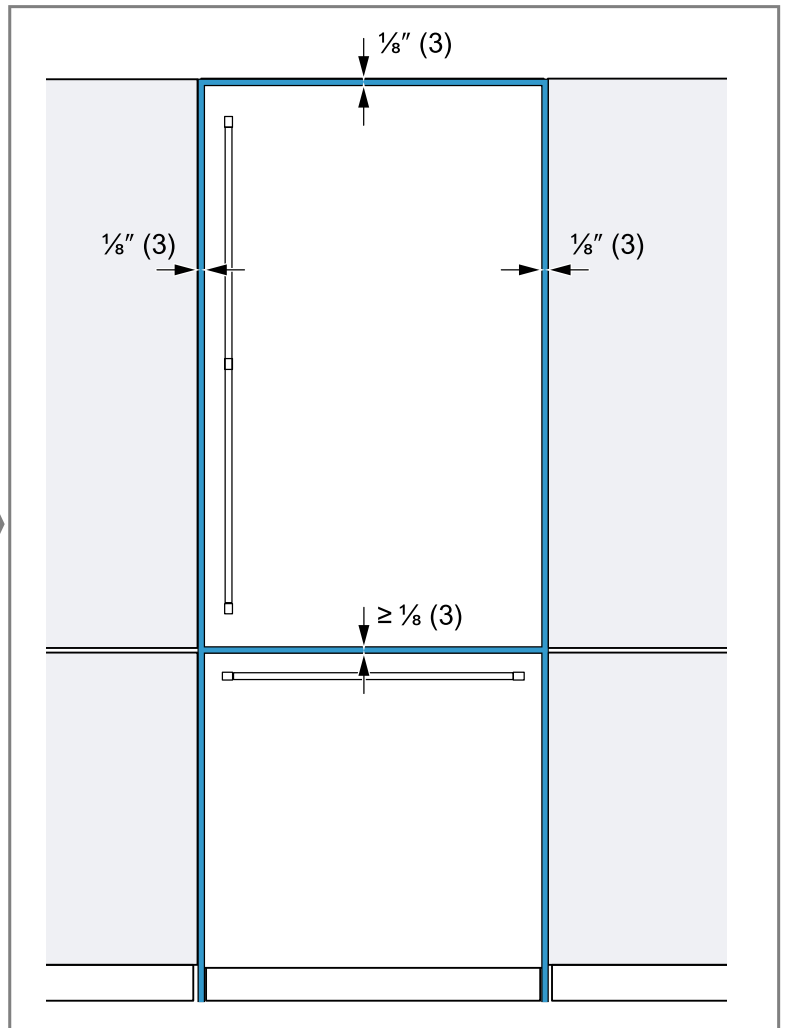
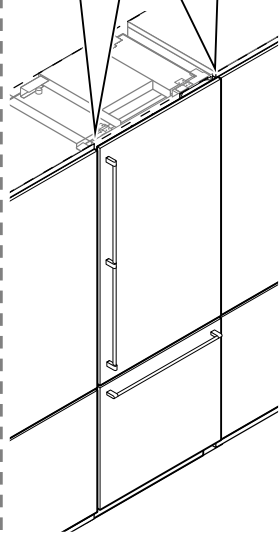
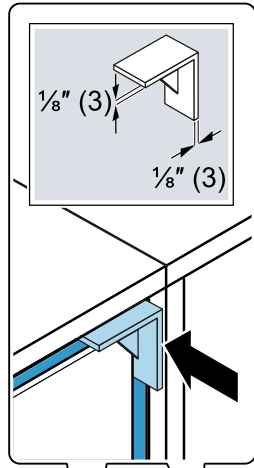
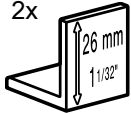

T3

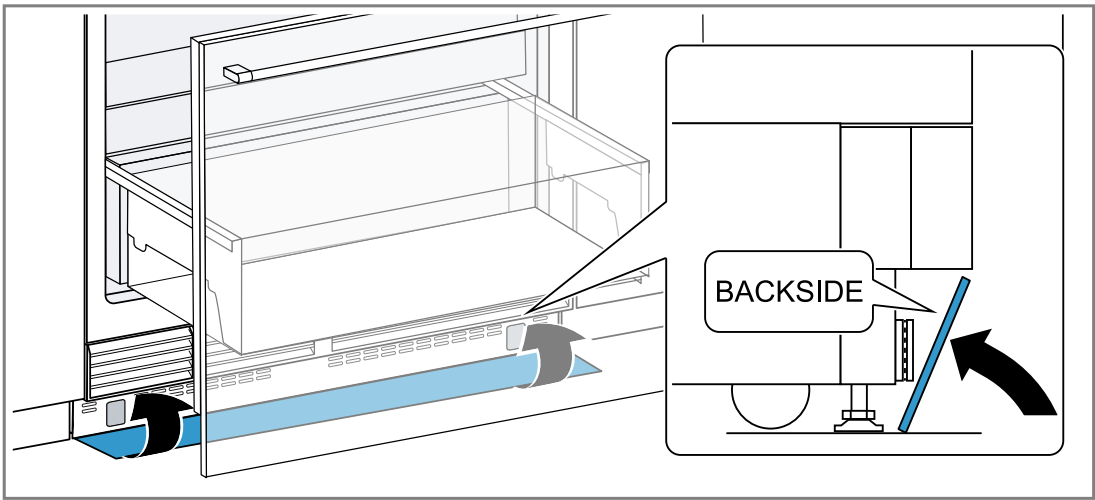
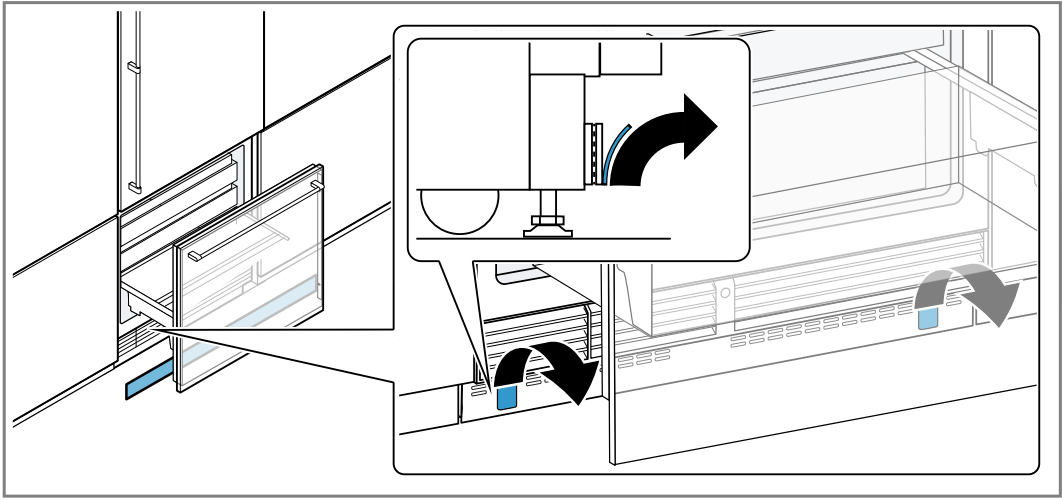
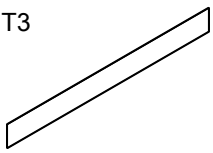

T4

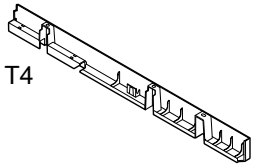

T5

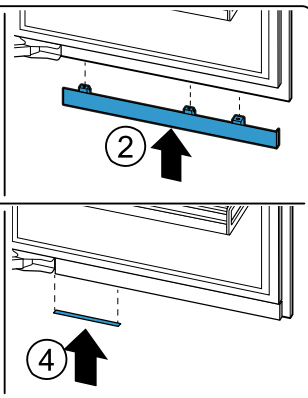
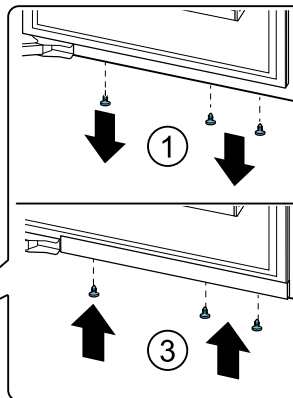
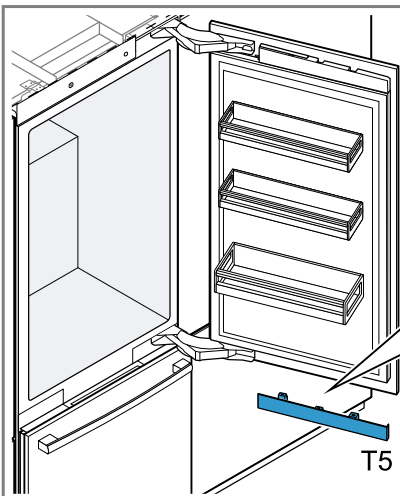
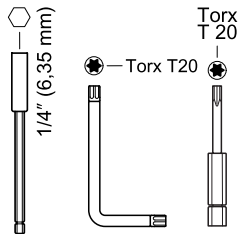
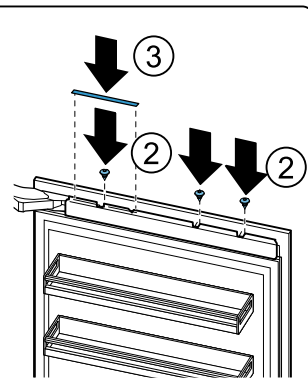
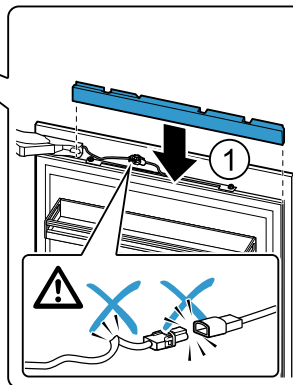
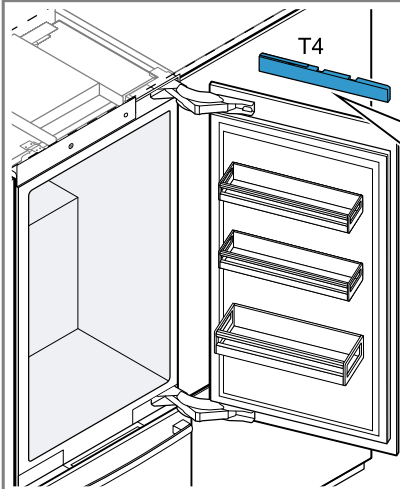
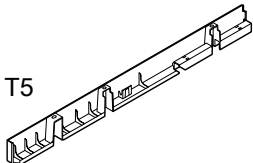

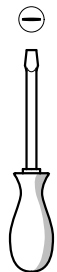
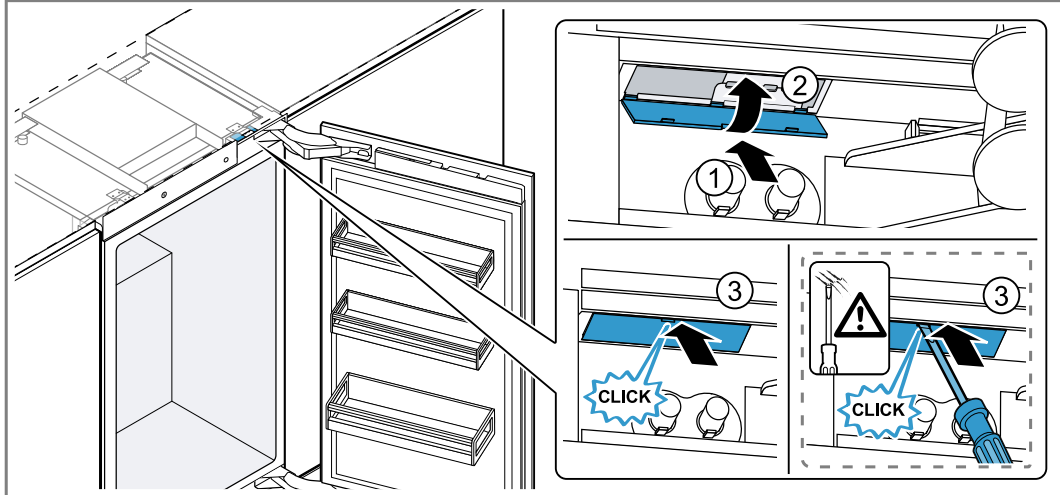
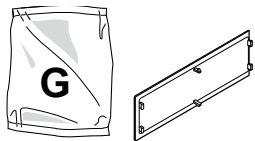

T6

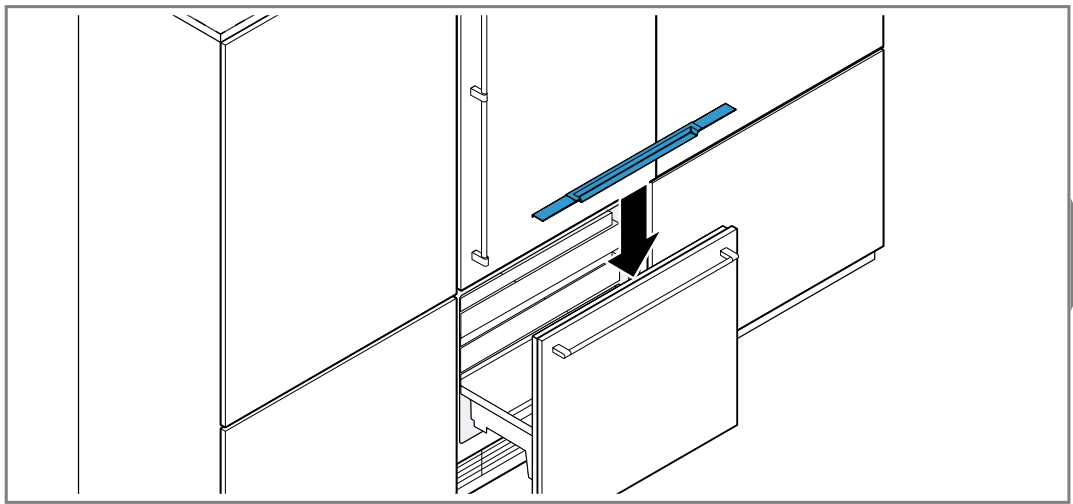
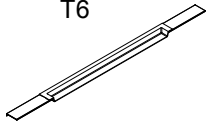

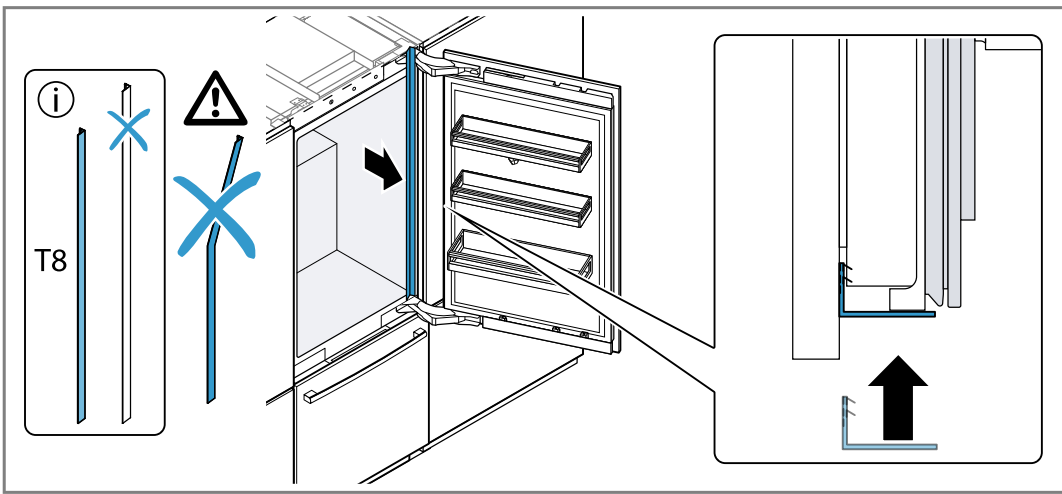
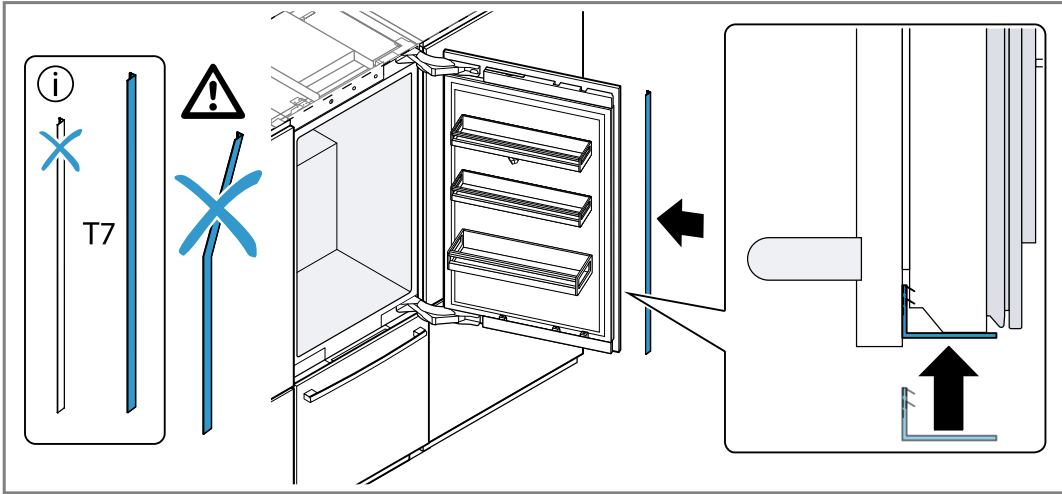

T9  
2x

