

100 Series, Dishwasher, 24", White SHE2ADF2N



- A smarter clean with PrecisionWash®
- Not just dry, but PureDry®
- Prevent leaks with AquaStop®
- Sleek and Simple Touch Control Panel
- **Favourite programme:** personalized function by just one touch.

UPC code: 825225981596
 Color: Not applicable
 Panel ready: No
 Watts: 1440 W
 Fuse protection: 12 A
 Volts: 120 V
 Frequency: 60 Hz
 Total Annual Energy Consumption: 269 kWh
 ENERGY STAR®: No
 Plug type: Nema5-15P
 Required Cutout Size (HxWxD) (in): 33 7/8" x 24" x 24"
 Required cutout size (HxWxD): 860-890 x 610 x 610 mm
 Power Cord Length: 67"
 Power cord length: 170 cm
 Length Outlet Hose (in): 90 1/2"
 Length outlet hose: 230 cm
 Product Packaging Dimensions (HxWxD): 35 7/8" x 26 7/8" x 26"
 Product packaging dimensions (HxWxD): 930x670x660 mm
 Tub Material: Stainless steel with Polinox base
 ADA Compliant: No
 Number of Place Settings: 12



- SMZSH1ABUC Supply Hose with Elbow
- SGZ1010UC Drain hose extension kit
- SMZ3IN1UC Dish Install Accessory Kit
- SMZ4000UC silverware basket US Duo
- SMZ5000 Dishwashing aid set
- SMZEPCC1UC Cabinet protector with power cord clips
- SMZPCJB1UC Powercord with Junction Box

100 Series, Dishwasher, 24", White SHE2ADF2N

measurements in inches (mm)

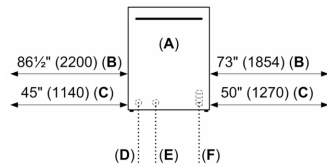

The electrical power cable and drain connections are in the rear of the appliance. The inlet is in the front. Extension for drain hose available as an accessory. Junction box for hard-wired connection available as an accessory.

A: Front view
 B: Drain hose
 C: Electrical power cable:
 Length shown corresponds
 to installation instructions
 D: Inlet
 E: Drain
 F: Electrical

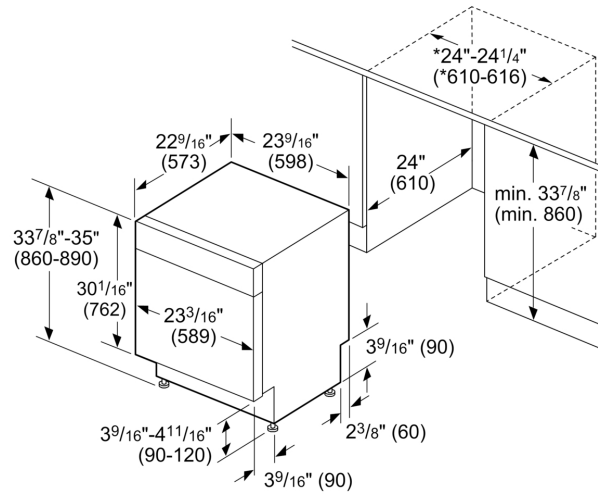

*23 5/8" (600) without decor strips

measurements in inches (mm)