

# AEG

## RANGE HOODS - REGENT SERIES

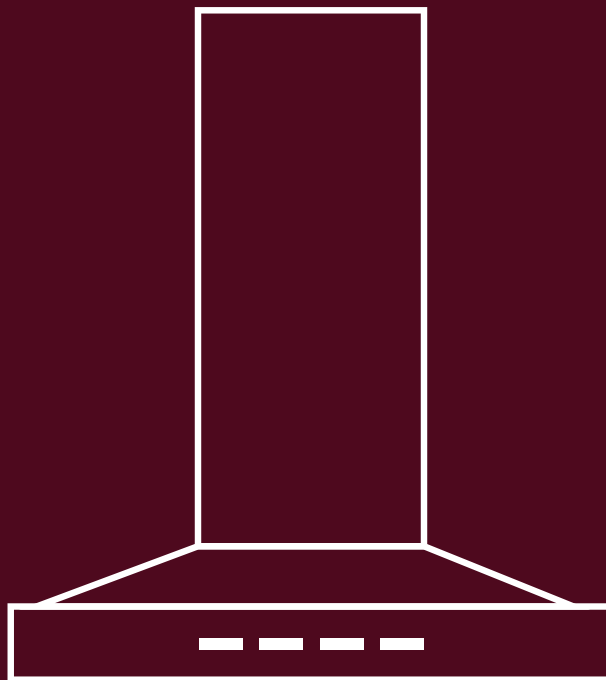

**RUC489**

48" Stainless Steel Under Cabinet Hood

## 48" Stainless Steel Under Cabinet Hood REGENT SERIES



Stainless Steel



### FEATURES & BENEFITS

**3 Fan Speeds** Provides great performance that allows you to adjust ventilation to meet your needs.

**900 CFM Motor** Quickly clear your kitchen of unwanted air pollution.

**LED Lighting** With high suction power and low noise, it is designed to remove cooking fumes from your kitchen quietly and effectively.

**Stainless Steel Baffle Filters** The sturdy, heavy duty baffle filters are durable and long lasting. The baffles force the airflow to change multiple times, effectively separating smoke, steam and grease with minimal maintenance.

### GENERAL PROPERTIES

Type	Under cabinet hood
Material thickness (Gauge)	22 Gauge (0.8mm)
Control	Soft touch control
Switch indicator	Front
Light (Type / number)	1x 5W strip LED in warm white, 4500K
Light position	Front
Air duct (inch)	Painted metallic, 7"
Filter	Heavy duty stainless steel baffle filter x 4
Width (inch)	48"
Number of motors	1
Number of speed settings	3 speeds (Low-Mid-Hi)
Timer function	5 minutes auto shut off motor and light
Motor (Type)	250W DC motor
Total power input(W)	255W
Air flow for exhaust CFM	900 CFM
Power cord & Plug	Canadian plug, 3' cord
Power input	AC 120V~ / 60Hz

### DIMENSIONS

Product Dimensions (in / mm) (W / D / H)	48" / 22 1/2" / 16 5/8" (1218mm / 562mm / 422mm)
Weight (lbs/kg)	68 lbs / 31 kg

### WARRANTY

Parts & Labour	2 Years
----------------	---------

### DIMENSIONS

Product Dimensions	48" / 22 $\frac{1}{8}$ " / 16 $\frac{5}{8}$ "
(in / mm) (W / D / H)	(1218mm / 562mm / 422mm)

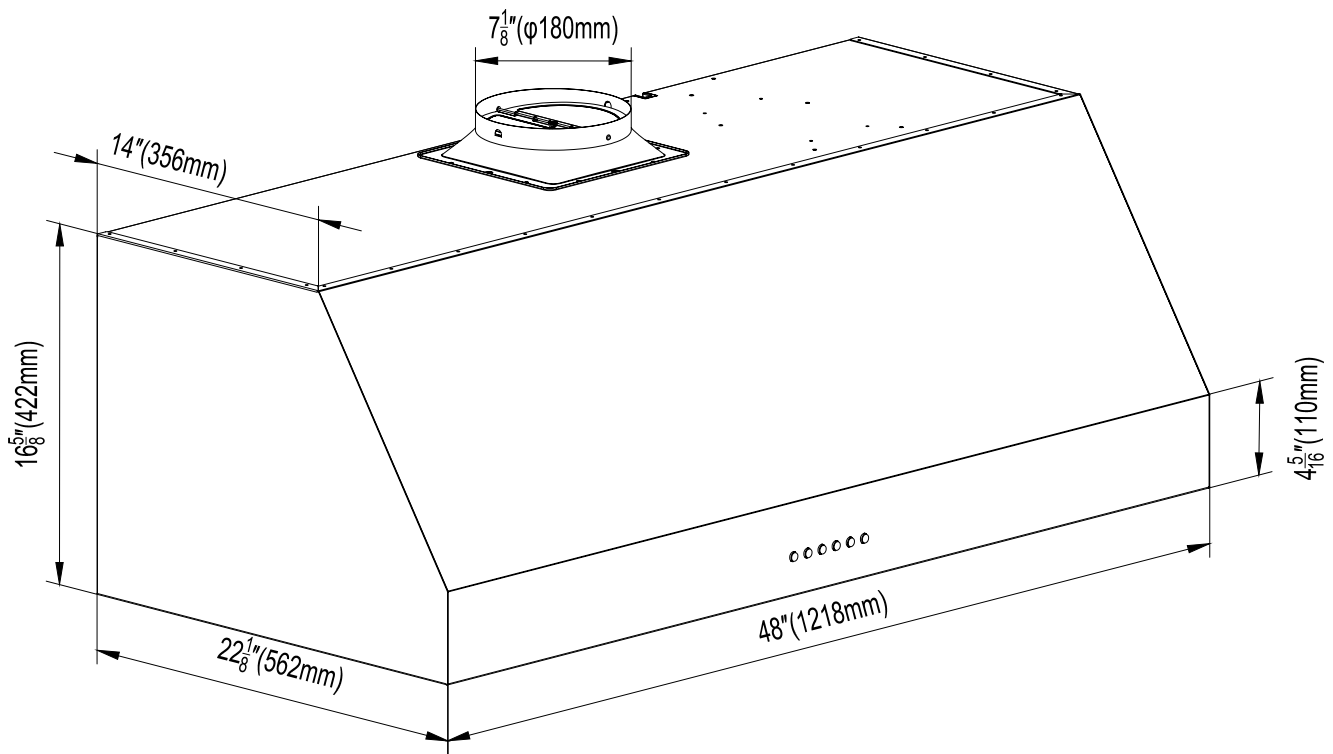

- Minimum clearance distance above the cooking surface is 24" (600mm).

Other Product Downloads Available at [aeg-appliances.ca](http://aeg-appliances.ca)

AEG is a registered trademark used under license from AB Electrolux (publ)

# AEG

## WARRANTY INFORMATION

Each appliance is covered by a comprehensive 2-year parts and labour warranty.  
Refer to product warranty policy for complete terms and conditions.

## FOR PARTS & SERVICE

### *Euro-Parts & Service*

39822 Belgrave Road, Belgrave, ON. N0G 1E0 1 866 722 2262

[www.euro-parts.ca](http://www.euro-parts.ca) • [parts@euro-parts.ca](mailto:parts@euro-parts.ca) • [service@euro-parts.ca](mailto:service@euro-parts.ca)

AEG appliances are imported and distributed in North America by Euro-Line  
Appliances Inc. For more information, please visit one of our showrooms or  
[www.ela.ca](http://www.ela.ca)

All aspects of the installation must conform with the requirements of the standard North American wiring rules, as well as your local electrical and building codes and regulations, and any other applicable requirements or conditions of your local power supply authority. A licensed electrician must perform the electrical work when installing this appliance. The supply cable and fuse rating must be suitable for the appliance.\*

## ***EURO-LINE APPLIANCES INC.***

---

871 Cranberry Court  
Oakville, ON, Canada, L6L 6J7  
905-829-3980 / [info@ela.ca](mailto:info@ela.ca)

101-1014 Homer Street  
Vancouver, BC, Canada, V6B 2W9  
604-235-3980 / [infowest@ela.ca](mailto:infowest@ela.ca)